

PVM-2950Q / 2950QM

RM-854

SERVICE MANUAL

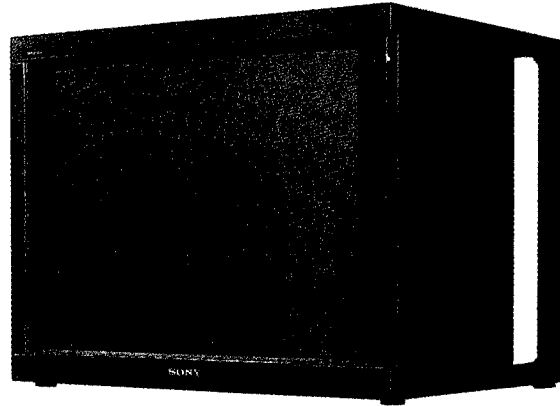

US Model
Canadian Model

PVM-2950Q

Chassis No. SCC-G61E-A

AEP Model

PVM-2950QM

Chassis No. SCC-G62D-A

Aus Model

PVM-2950QM

Chassis No. SCC-H03B-A

MODELS OF THE SAME SERIES

PVM-2950Q/2950QM	

SPECIFICATIONS

Video signal

Picture tube

29" Super Trinitron tube
Visible picture size : 675 mm
(27" measured diagonally)
AG pitch : 0.70 - 0.85 mm

Color system

Resolution

Frequency response

Anti-glare & Anti-static
NTSC, PAL, SECAM, NTSC4.43, PAL60
600 TV lines at the center
VIDEO : 7 MHz (-3 dB)
S VIDEO : 8 MHz (-3 dB)
RGB : 10 MHz (-3 dB)

Picture performance

Color temperature

Line pull range

Overscan

Zooming

9300K/6500K (standard)/3200K
switchable

Horizontal : ± 500 Hz

Vertical : -8 Hz

7% preset ($\pm 3\%$ variable)

Within 5%

- Continued on next page -

TRINITRON® COLOR VIDEO MONITOR
SONY®



Inputs and Outputs

VIDEO IN	BNC connector 1 Vp-p, sync negative 75-ohm (auto), loop through
Y/C IN	4-pin mini DIN connector Y : 1 Vp-p, sync negative C : 0.286 Vp-p (burst signal) (NTSC) 0.3 Vp-p (PAL) 75-ohm (auto), loop through
AUDIO IN (L, R)	Phono jack -5 dBs high impedance, loop through
R/R-Y, G/Y, B/B-Y IN	BNC connector R, G, B channels : 0.714 Vp-p./non-composite, 75-ohm terminated (525 lines) 0.7 Vp-p./non composite, 75-ohm terminated (625 lines) 1 Vp-p./composite, 75-ohm terminated Y channel : 1.0 Vp-p./composite, 75-ohm terminated 0.7 Vp-p./non composite, 75-ohm terminated R-Y, B-Y channels : 0.7 Vp-p, 75-ohm terminated
Sync input	BNC connector H (or composite) SYNC, V SYNC, 0.5 - 5 Vp-p, 75-ohm terminated
Speaker output	8-16 ohm, 7 W + 7 W

(CAUTION)

SHORT CIRCUIT THE ANODE OF THE PICTURE TUBE AND THE ANODE CAP TO THE METAL CHASSIS, CRT SHIELD, OR CARBON PAINTED ON THE CRT, AFTER REMOVING THE ANODE.

WARNING!!

AN ISOLATION TRANSFORMER SHOULD BE USED DURING ANY SERVICE TO AVOID POSSIBLE SHOCK HAZARD, BECAUSE OF LIVE CHASSIS. THE CHASSIS OF THIS RECEIVER IS DIRECTLY CONNECTED TO THE AC POWER LINE.

SAFETY-RELATED COMPONENT WARNING !!

COMPONENTS IDENTIFIED BY SHADING AND MARK Δ ON THE SCHEMATIC DIAGRAMS, EXPLODED VIEWS AND IN THE PARTS LIST ARE CRITICAL TO SAFE OPERATION. REPLACE THESE COMPONENTS WITH SONY PARTS WHOSE PART NUMBERS APPEAR AS SHOWN IN THIS MANUAL OR IN SUPPLEMENTS PUBLISHED BY SONY. CIRCUIT ADJUSTMENTS THAT ARE CRITICAL TO SAFE OPERATION ARE IDENTIFIED IN THIS MANUAL. FOLLOW THESE PROCEDURES WHENEVER CRITICAL COMPONENTS ARE REPLACED OR IMPROPER OPERATION IS SUSPECTED.

General

Power requirements	PVM-2950Q 100 - 120 V AC, 50/60 Hz, MAX. 3.7 A PVM-2950QM 220 - 240 V AC, 50/60 Hz, MAX. 1.2 A
Operating temperature range	0 - 35° C (32 - 95° F)
Dimensions	687×538×529 mm (w/h/d) (27 1/8×21 1/4×20 7/8 inches)
Mass	52 kg (114 lb 10 oz)
Supplied accessories	AC power cord (1) AC plug holder (1) Remote commander RM-854 with a battery (1)
Optional accessories	
Speaker system	SS-X6A
TV tuner	ST-92TV (USA only)

Design and specifications are subject to change without notice.

(ATTENTION)

APRES AVOIR DECONNECTE LE CAP DE L'ANODE, COURT-CIRCUITER L'ANODE DU TUBE CATHODIQUE ET CELUI DE L'ANODE DU CAP AU CHASSIS METALLIQUE DE L'APPAREIL, OU AU COUCHE DE CARBONE PEINTE SUR LE TUBE CATHODIQUE OU AU BLINDAGE DU TUBE CATHODIQUE.

ATTENTION!!

AFIN D'EVITER TOUT RISQUE D'ELECTROCUTION PROVENANT D'UN CHASSIS SOUS TENSION, UN TRANSFORMATEUR D'ISOLEMENT DOIT ETRE UTILISE LORS DE TOUT DEPANNAGE. LE CHASSIS DE CE RECEPTEUR EST DIRECTEMENT RACCORDE A L'ALIMENTATION SECTEUR.

ATTENTION AUX COMPOSANTS RELATIFS A LA SECURITE!!

LES COMPOSANTS IDENTIFIES PAR UNE TRAME ET PAR UNE MAPQUE Δ SUR LES SCHEMAS DE PRINCIPE, LES VUES EXPLOSEES ET LES LISTES DE PIECES CONT D'UNE IMPORTANCE CRITIQUE POUR LA SECURITE DU FONCTIONNEMENT. NE LES REMPLACER QUE PAR DES COMPOSANTS SONY DONT LE NUMERO DE PIECE EST INDIQUE DANS LE PRESENT MANUEL OU DANS DES SUPPLEMENTS PUBLIES PAR SONY. LES REGLAGES DE CIRCUIT DONT L'IMPORTANCE EST CRITIQUE POUR LA SECURITE DU FONCTIONNEMENT SONT IDENTIFIES DANS LE PRESENT MANUEL. SUIVRE CES PROCEDURES LORS DE CHAQUE REMPLACEMENT DE COMPOSANTS CRITIQUES, OU LORSQU'UN MAUVAIS FONCTIONNEMENT EST SUSPECTE.

SAFETY CHECK-OUT

(US model only)

After correcting the original service problem, perform the following safety checks before releasing the set to the customer :

1. Check the area of your repair for unsoldered or poorly-soldered connections. Check the entire board surface for solder splashes and bridges.
2. Check the interboard wiring to ensure that no wires are "pinched" or contact high-wattage resistors.
3. Check that all control knobs, shields, covers, ground straps, and mounting hardware have been replaced. Be absolutely certain that you have replaced all the insulators.
4. Look for unauthorized replacement parts, particularly transistors, that were installed during a previous repair. Point them out to the customer and recommend their replacement.
5. Look for parts which, though functioning, show obvious signs of deterioration. Point them out to the customer and recommend their replacement.
6. Check the line cord for cracks and abrasion. Recommend the replacement of any such line cord to the customer.
7. Check the condition of the monopole antenna (if any). Make sure the end is not broken off, and has the plastic cap on it. Point out the danger of impalement on a broken antenna to the customer, and recommend the antenna's replacement.
8. Check the B+ and HV to see they are at the values specified. Make sure your instruments are accurate; be suspicious of your HV meter if sets always have low HV.
9. Check the antenna terminals, metal trim, "metallized" knobs, screws, and all other exposed metal parts for AC leakage. Check leakage as described below.

LEAKAGE TEST

The AC leakage from any exposed metal part to earth ground and from all exposed metal parts to any exposed metal part having a return to chassis, must not exceed 0.5mA (500 microamperes). Leakage current can be measured by any one of three methods.

1. A commercial leakage tester, such as the Simpson 229 or RCA WT-540A. Follow the manufacturers' instructions to use these instruments.
2. A battery-operated AC milliammeter. The Data Precision 245 digital multimeter is suitable for this job.
3. Measuring the voltage drop across a resistor by means of a VOM or battery-operated AC voltmeter. The "limit" indication is 0.75V, so analog meters must have an accurate low-voltage scale. The Simpson 250 and Sanwa SH-63Trd are examples of a passive VOM that is suitable. Nearly all battery operated digital multimeters that have a 2V AC range are suitable. (See Fig. A)

HOW TO FIND A GOOD EARTH GROUND

A cold-water pipe is guaranteed earth ground; the cover-plate retaining screw on most AC outlet boxes is also at earth ground. If the retaining screw is to be used as your earth-ground, verify that it is at ground by measuring the resistance between it and a cold-water pipe with an ohmmeter. The reading should be zero ohms. If a cold-water pipe is not accessible, connect a 60-100 watts trouble light (not a neon lamp) between the hot side of the receptacle and the retaining screw. Try both slots, if necessary, to locate the hot side of the line, the lamp should light at normal brilliance if the screw is at ground potential. (See Fig. B)

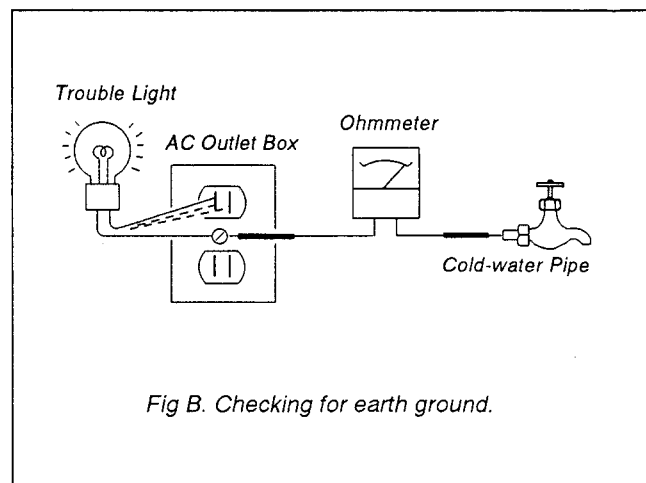
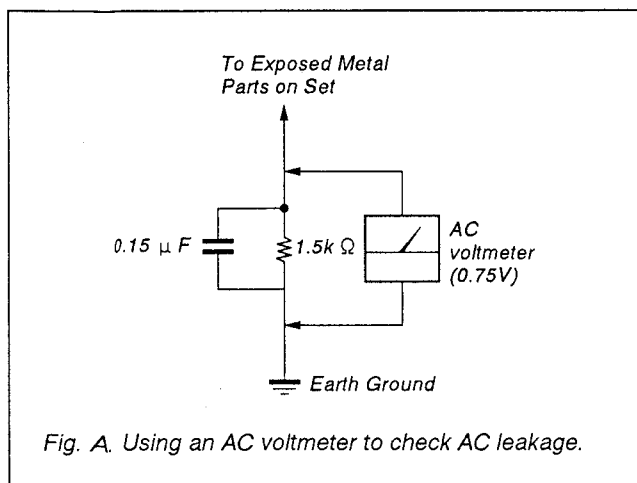

TABLE OF CONTENTS

<u>Section</u>	<u>Title</u>	<u>Page</u>	<u>Section</u>	<u>Title</u>	<u>Page</u>
1. GENERAL			6. CIRCUIT ADJUSTMENTS		
	Features	5	6-1. B Board Adjustments		31
	Location and Function of Parts and Controls	6	6-2. A Board Adjustment		36
	Power Sources	9	6-3. UT Board Adjustment		37
	Using On-screen Menus	10	6-4. VC Board Adjustment		37
	Operating a Specific Monitor with the Remote Commander	12			
2. DISASSEMBLY			7. DIAGRAMS		
2-1. Rear Cover Removal		13	7-1. Block Diagrams (1)		39
2-2. Chassis Assy Removal		13	Block Diagrams (2)		44
2-3. Service Position		14	7-2. Frame Schematic Diagram		49
2-4. UA Board Removal		14	7-3. Circuit Boards Location		52
2-5. B Board Removal		14	7-4. Schematic Diagrams and Printed Wiring Boards		52
2-6. UJ Board Removal		15	• VC Board		53
2-7. G1 Board Removal		15	• G1 Board		53
2-8. G Board Removal		16	• G Board		54
2-9. UT Board Removal		16	• H2 Board		55
2-10.A Board Removal		17	• H3 Board		55
2-11.Extension Cable		17	• A Board		65
2-12.Extension Board		18	• B Board		70
2-13.Key Board Unit and Blind Panel Removal		18	• DX Board		81
2-14.Degaussing Coil Removal		19	• V Board		83
2-15.Picture Tube Removal		19	• M Board		83
2-16.Hamess Location		20	• UT Board		87
			• UJ Board		89
3. SET-UP ADJUSTMENTS			• UA Board		90
3-1. Beam Landing		22	• C Board		94
3-2. Convergence Adjustment		23	7-5. Semiconductors		97
3-3. Focus Adjustment		26			
3-4. Screen (G2) White Balance Adjustment		26	8. EXPLODED VIEWS		
4. SAFETY RELATED ADJUSTMENT		27	8-1. Rear Cover		99
5. ELECTRIC ADJUSTMENT IN THE SERVICE MODE		29	8-2. Picture Tube		100
			8-3. Chassis		101
			9. ELECTRICAL PARTS LIST		102

SECTION 1 GENERAL

The operating instructions mentioned here are partial abstracts from the Operating Instruction Manual. The page numbers of the Operating Instruction Manual remain as in the manual.

Features

Trinitron picture tube

The Trinitron picture tube provides a flat and high resolution picture. Horizontal resolution is more than 600 TV lines at the center of the picture.

Four color systems available

The monitor can display NTSC, PAL*, SECAM, NTSC_{4:43}** signals. The appropriate color system is selected automatically.

* If you set PAL to ON in the menu, the monitor can also display the PAL60 signal.

**The NTSC_{4:43} signal is used for playing back NTSC recorded video cassettes with a video tape recorder/ player especially designed for use with this system.

Index number

You can operate a specific monitor among several monitors by using the index number features.

On-screen menus

You can adjust the settings by using the on-screen menus.

Control S

The CONTROL S signal allows remote control of several monitors and a VCR through a single monitor.

Blue only mode

In this mode, only a blue signal is displayed on the screen turning off the red and green signals. This facilitates color saturation and phase adjustments.

RGB/component input connectors

RGB or component (Y,R-Y,B-Y) signals from video equipment can be input through these connectors.

Y/C input connector

The video signal, split into the chrominance signal (C) and the luminance signal (Y), can be input through this connector, eliminating the interference between the two signals, which tends to occur in a composite video signal, assuring video quality.

This manual covers PVM-2950Q and PVM-2950QM. The model number is located on the rear.
The operating procedures of all models are the same.

Location and function of parts and controls

Front panel

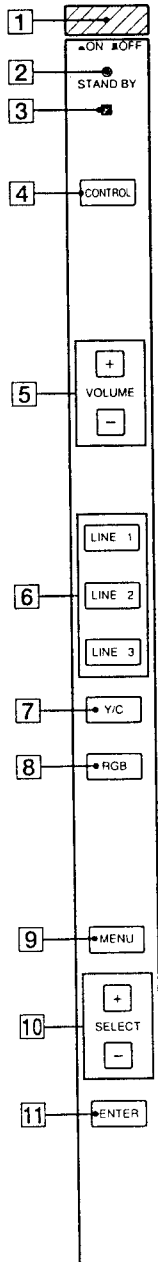

- 1 POWER switch**
Press to turn the monitor on. Press again to turn it off.
- 2 STANDBY indicator**
Lights up when the monitor is turned off with the remote commander.
- 3 Remote sensor**
Receives the beam from the remote commander.
- 4 CONTROL key**
To operate the keys on the front panel, first press this key. Then the keys light up or flash that shows they can be operated. Press again to deactivate them.
- 5 VOLUME +/- keys**
Press to obtain the desired volume.
- 6 LINE 1, LINE 2, LINE 3 keys***
Press to select the line inputs.
- 7 Y/C key***
Press to select the Y/C input of LINE 1 or LINE 2.
- 8 RGB key***
Press to select the RGB input of LINE 3.
- 9 MENU key**
Press to make the menu appear or to go to the following menu.
- 10 SELECT +/- key**
Press to move the cursor (▶) to an item or to adjust value in a menu.
- 11 ENTER key**
Press to select the desired item in a menu.

* Each key acts as follows.

CONTROL	On	Off
Selected key	Flash	Light up
Not selected key	Light up	Light off

Note

If the picture disappears suddenly and the STANDBY indicator flashes, there may be a failure in the monitor. Unplug the unit and call your authorized Sony dealer.

Rear panel

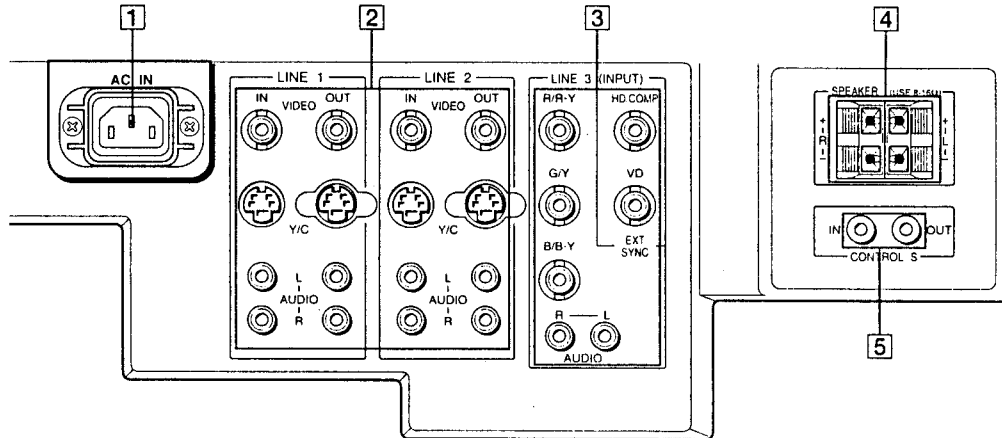

1 AC IN socket

Connect the supplied AC power cord to this socket and to a wall outlet.

2 LINE 1, LINE 2 connectors

VIDEO IN (BNC)

Connect to the video output of video equipment, such as a VCR or a color video camera. For a loop-through connection, connect to the video output of another monitor.

VIDEO OUT (BNC)

Loop-through output of the VIDEO IN connector.

Connect to the video input of a VCR or another monitor.

Y/C IN (4-pin mini DIN)

Connect to the Y/C separate output of a video camera, VCR or other video equipment.

Y/C OUT (4-pin mini DIN)

Loop-through output of the Y/C IN connector. Connect to the Y/C separate input of a VCR or another monitor.

AUDIO IN (phono)

Connect to the audio output of a VCR or to a microphone via a suitable microphone amplifier. For a loop-through connection, connect to the audio output of another monitor.

AUDIO OUT (phono)

Loop-through output of the AUDIO IN jack. Connect to the audio input of a VCR or another monitor.

3 LINE 3 connectors

R/R-Y IN, G/Y IN, B/B-Y IN (BNC)

When the RGB input is selected (RGB key on the front panel is lit), connect to the RGB signal outputs of a video camera. When the R-Y, G/Y, B-Y input is selected (RGB key is not lit), connect to the R-Y/Y/B-Y component signal outputs of a Sony Betacam video camera.

HD/COMP (BNC)

Connect to the H sync signal or composite sync signal output.

VD (BNC)

Connect to the V sync signal output.

Note

External sync signal is selected automatically. See the priority chart below.

Input connector	Input sync signals		
HD/COMP	H Sync	Comp Sync	---
VD	V Sync	---	---
G	Sync on G	Sync on G	Sync on G
Sync signals to be selected	H Sync V Sync	Comp Sync	Sync on G

AUDIO IN (phono)

Connect to the audio output of a VCR.

4 SPEAKER L/R terminals

Connect to speakers with 8 to 16 ohms impedance.

Note

Do not connect the speaker's cord to the monitor and to an amplifier simultaneously, or an excessive electric current might flow from the amplifier and damage the monitor.

5 CONTROL S IN/OUT connectors

Connect to the CONTROL S connectors of a VCR or several monitors. Then you can control the system with a single remote commander.

Note

If you connect CONTROL S IN to the other equipment's CONTROL S OUT connector, you cannot operate the monitor with the supplied remote commander.

Location and function of parts and controls (continued)

Remote commander

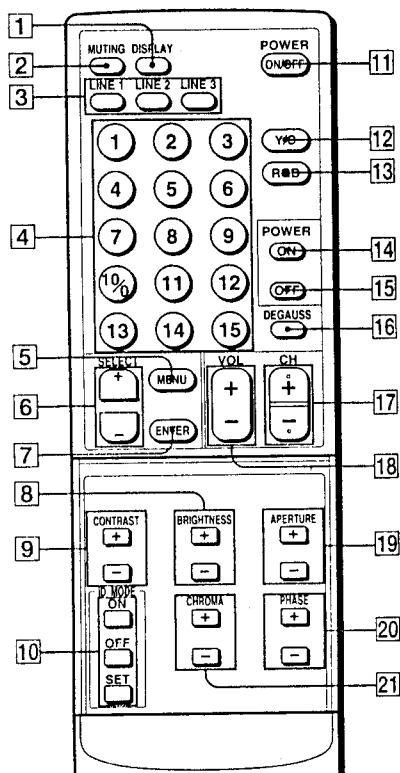

Installing battery

Insert a size AA (R6) battery in correct polarity.

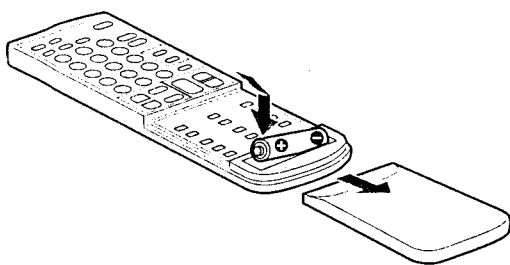

Notes

- In normal operation, a battery will last up to half a year. If the remote commander does not operate properly, the battery might be exhausted. Replace it with new one.
- To avoid damage from possible battery leakage, remove the battery if you do not plan to use the remote commander for a fairly long time.

- 1 DISPLAY button**
Press to display the color system and the selected line input.
- 2 MUTING button**
Press to mute the sound.
- 3 LINE 1/LINE 2/LINE 3 buttons**
Press to choose the line input.
- 4 Number buttons**
Press to select the index number. Cannot use the 11 to 15 buttons with the monitor.
- 5 MENU button**
Press to make the menu appear or to go to the following menu.
- 6 SELECT +/- buttons**
Press to move the cursor (▶) to an item or to adjust value in a menu.
- 7 ENTER button**
Press to select the desired item in a menu.
- 8 BRIGHTNESS +/- buttons**
Press the + button to make the picture brighter or the - button to make it darker.
- 9 CONTRAST +/- buttons**
Press the + button to increase the contrast or the - button to decrease it.
- 10 ID MODE buttons**
Press ON to make an index number appear on the screen. Then press the index number of the monitor you want to operate and press SET. After you finish the operation, press OFF to return to the normal mode.
- 11 POWER ON/OFF button**
Press to turn on the monitor. Press again to turn it off.
- 12 Y/C button**
Press to select the Y/C input of LINE 1 or LINE 2.
- 13 RGB button**
Press to select the RGB input of LINE 3. If you do not press this button (RGB key is not lit), the component input is selected on LINE 3.
- 14 POWER ON button**
Press to turn on the monitor. Use this button instead of the POWER ON/OFF button when you do not want to let another monitor be affected.
- 15 POWER OFF button**
Press to turn off the monitor. Use this button instead of the POWER ON/OFF button when you do not want to let another monitor be affected.

Power sources

16 DEGAUSS button

Press to demagnetize the screen. Wait for 10 minutes or more before activating this feature again. The same interval is needed after turning on the monitor.

17 CH +/- buttons

(Cannot use these buttons with the monitor.)

18 VOL +/- buttons

Press to obtain the desired volume.

19 APERTURE +/- buttons

Press the + button for more sharpness or the - button for less sharpness. (This adjustment has no effect on the pictures of RGB signals.)

20 PHASE +/- buttons

Press the + button to make the skin tones greenish or the - button to make them purplish. (NTSC signal only)

21 CHROMA +/- buttons

Press the + button to increase the color intensity and the - button to decrease it. (This adjustment has no effect on the pictures of RGB signals.)

Connect the AC power cord (supplied) to the AC IN socket and to a wall outlet.

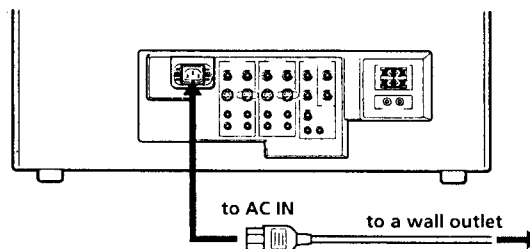

To connect an AC power cord securely with an AC plug holder

- 1 Plug the power cord into the AC IN socket. Then, attach the AC plug holder (supplied) to the AC power cord.

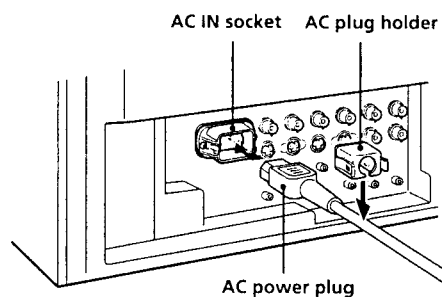

- 2 Slide the AC plug holder over the cord until it connects to the attached holder.

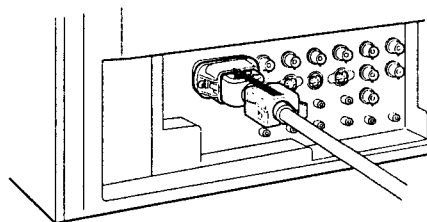

To remove the AC power cord

Squeeze the left and right sides and pull out the AC plug holder.

Using on-screen menus

Operating through menus

There are four buttons (keys) on the monitor and the remote commander for menu operations.

To display a menu, first press MENU. Press + or - to move the cursor (▶) and press ENTER to select an item.

To return to the normal screen, press the selected line input button (key).

Menu operating buttons

Remote commander

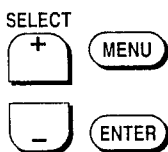

Monitor

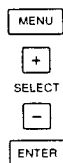

Each time you press MENU, the screen changes as shown below. For details see the following guide.

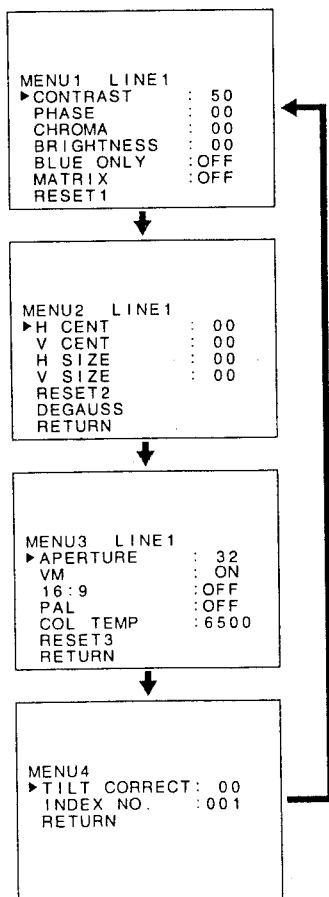

Menu guide

You can adjust the picture for each line input. Select the line input by pressing the line input button (key) before making adjustments.

The items on Menu 4 are common for all line inputs.

Menu 1

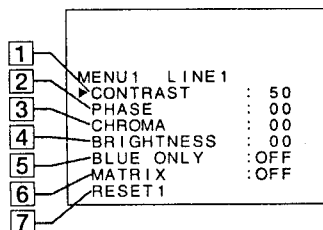

1 CONTRAST

Press + to increase the contrast and press - to decrease it.

2 PHASE

Press + to make the skin tones greenish and press - to make them purplish. (NTSC signal only)
(Set MATRIX to OFF when adjusting this item.)

3 CHROMA

Press + to increase the color intensity and press - to decrease it.
(Set MATRIX to OFF when adjusting this item.)

4 BRIGHTNESS

Press + to make the picture brighter and press - to make it darker.

5 BLUE ONLY

Select ON to turn off the red and green signals. Only a blue signal is displayed on the screen. This facilitates "chroma" and "phase" (NTSC signal only) control adjustments.

6 MATRIX

Select ON to activate the matrix circuit that may correct skin tones. (NTSC signal only)

7 RESET1

Select to restore the factory settings in MENU 1.

Menu 2

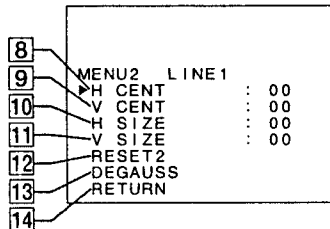

- 8 H CENT**
Adjusts the horizontal centering. Press + to move the picture to the right and press - to move it to the left.
- 9 V CENT**
Adjusts the vertical centering. Press + to move the picture up and press - to move it down.
- 10 H SIZE**
Adjusts the horizontal picture size. Press + to enlarge the horizontal size and press - to diminish it.
- 11 V SIZE**
Adjusts the vertical picture size. Press + to enlarge the vertical size and press - to diminish it.
- 12 RESET2**
Select to restore the factory settings in MENU 2.
- 13 DEGAUSS**
Select to demagnetize the screen. Wait for 10 minutes or more before activating this feature again. The same interval is needed after turning on the monitor.
- 14 RETURN**
Select to return to the MENU 1 screen.

Menu 3

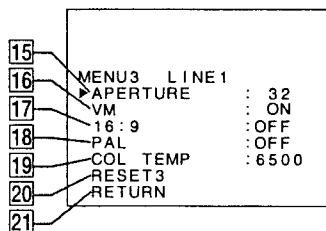

- 15 APERTURE**
Adjusts the picture sharpness. Press + for more sharpness or press - for less sharpness. (This adjustment has no effect on the pictures of RGB signals.)
- 16 VM**
Select ON to emphasize sharpness and to reproduce a clear picture. (This adjustment has no effect on the pictures of RGB signals.)

- 17 16:9**
Select ON for a 16:9 picture signal.

- 18 PAL**
Select ON when the monitor does not recognize the PAL signal. (You must select ON when the PAL60 signal is input.)

- 19 COL TEMP**
Select the color temperature from among 9300K, 6500K and 3200K.

- 20 RESET3**
Select to restore the factory settings in MENU 3.

- 21 RETURN**
Select to return to the MENU 2 screen.

Menu 4

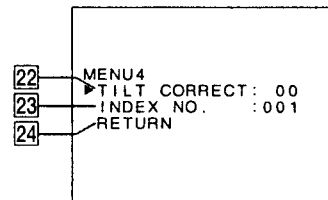

- 22 TILT CORRECT**
Adjusts the picture tilt due to the influence of the earth's magnetism. Press + to rotate the picture clockwise and press - to rotate it counterclockwise.
- 23 INDEX NO.**
Sets the index number of the monitor. You cannot set the number with the remote commander. Use the keys on the monitor. For more information about the index number, see "Operating a specific monitor with the remote commander."

- 24 RETURN**
Select to return to the MENU 3 screen.

Operating a specific monitor with the remote commander

By following procedure, you can operate a specific monitor with the remote commander without affecting other monitors that are installed together.

- 1 Press ID MODE ON on the remote commander.**
Monitor index numbers appear in white characters on all the monitors. (Every monitor has its own index number from 1 to 255 as factory preset.)

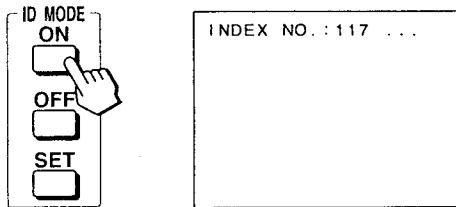

- 2 Input the index number of the monitor you want to operate using 0 - 9 buttons of the remote commander.**
The input number appears right next to each monitor's own index number.

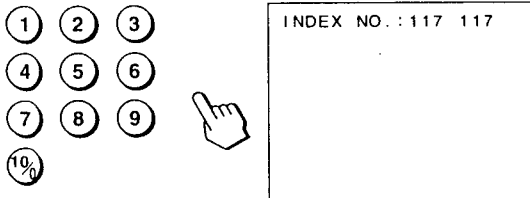

- 3 Press ID MODE SET.**
The character on the selected monitor changes to cyan while others change to red.

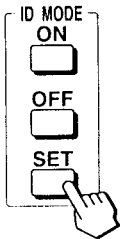

Now you can operate only a specified monitor. (All operations available in ID mode except POWER ON/OFF.)

- 4 After necessary adjustment, press ID MODE OFF.**
The monitor returns to the normal mode.

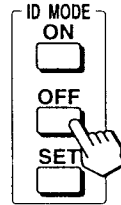

To change the index number

You can change the index number if necessary. You cannot change the number with the remote commander. Use the keys on the monitor.

- 1 Display MENU 4 screen with pressing the MENU button.
- 2 Select INDEX NO. and press ENTER.
- 3 Select the index number with the SELECT +/- buttons and press ENTER.

SECTION 2 DISASSEMBLY

2-1. REAR COVER REMOVAL

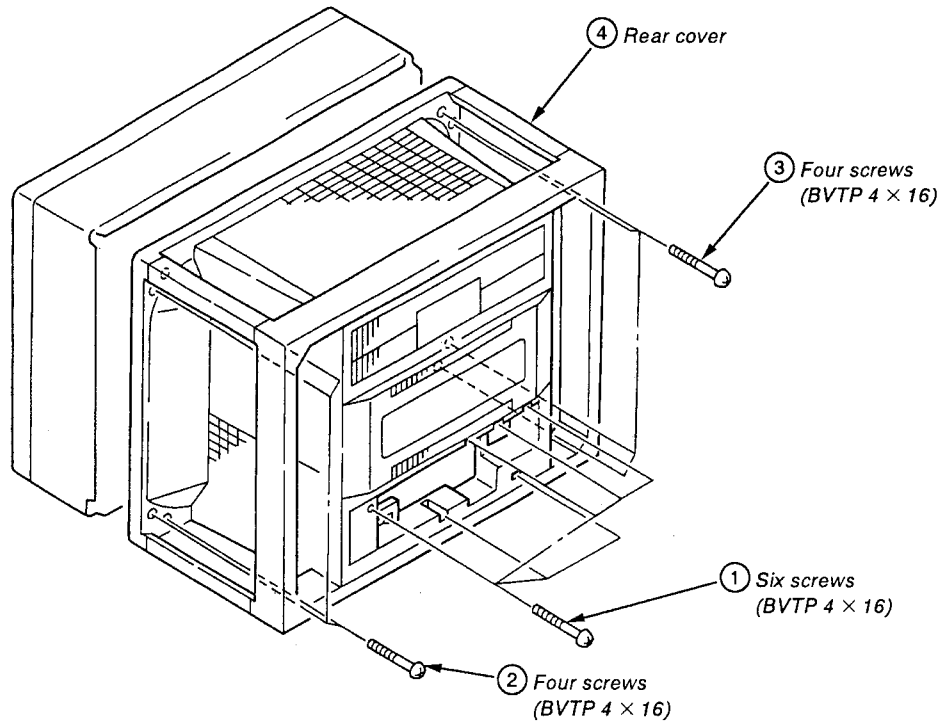

2-2. CHASSIS ASSY REMOVAL

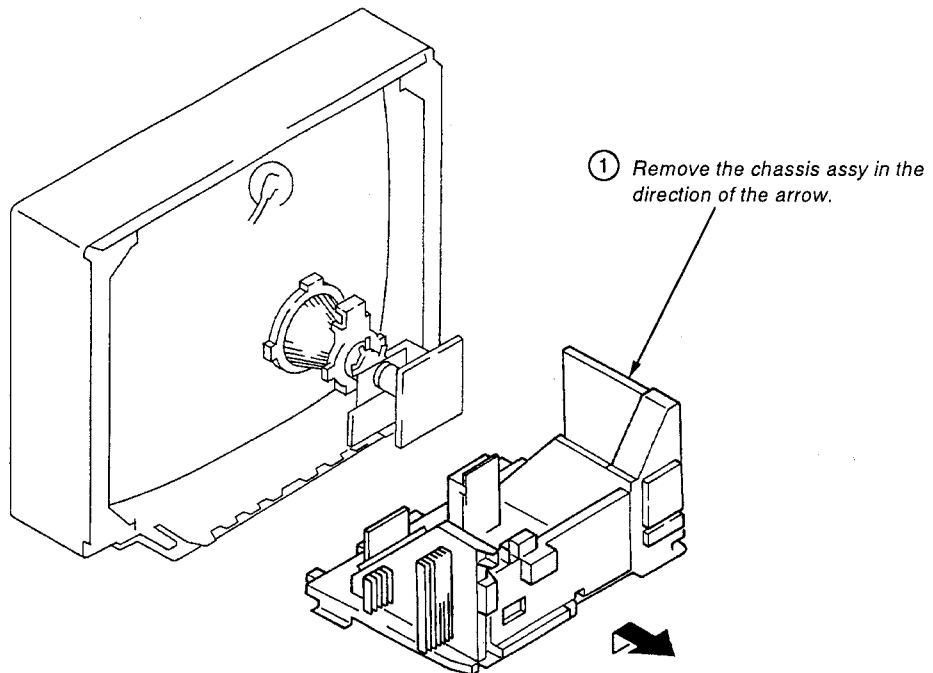

2-3. SERVICE POSITION

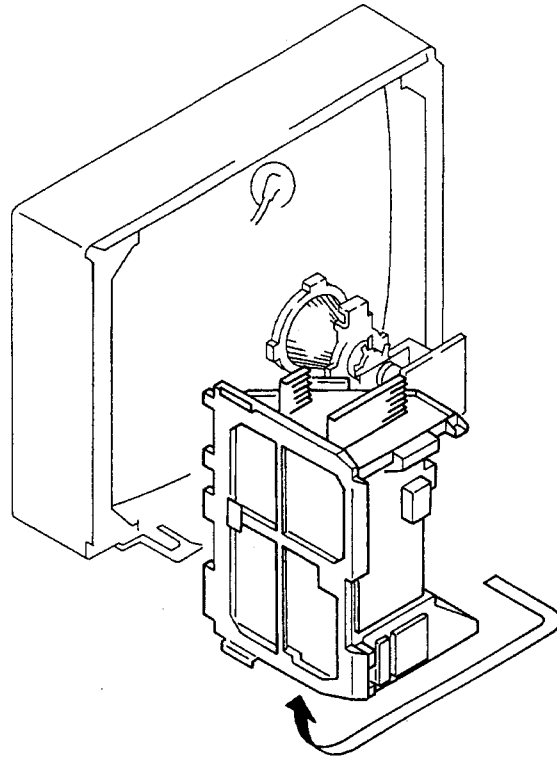

2-4. UA BOARD REMOVAL

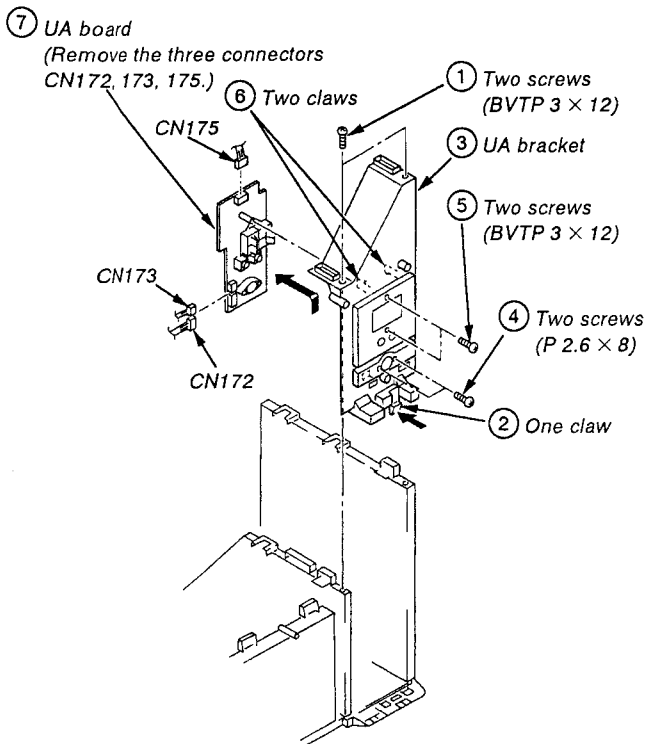

2-5. B BOARD REMOVAL

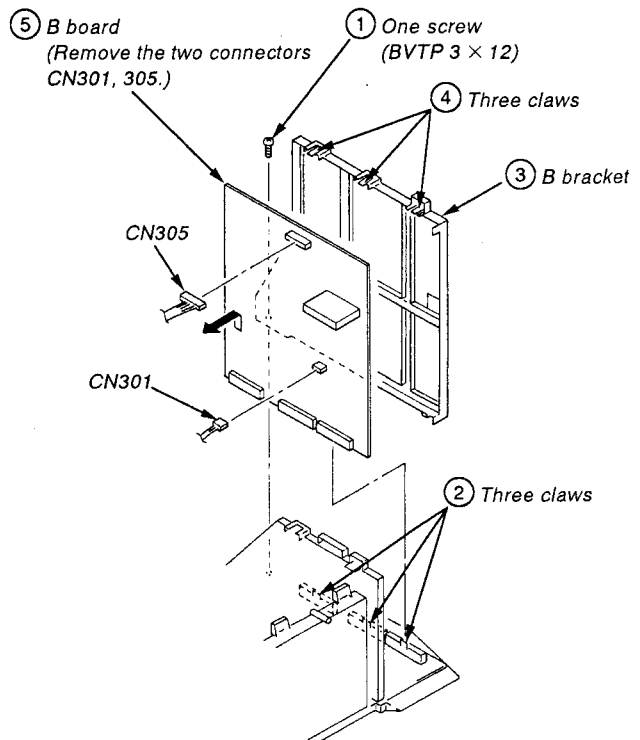

2-6. UJ BOARD REMOVAL

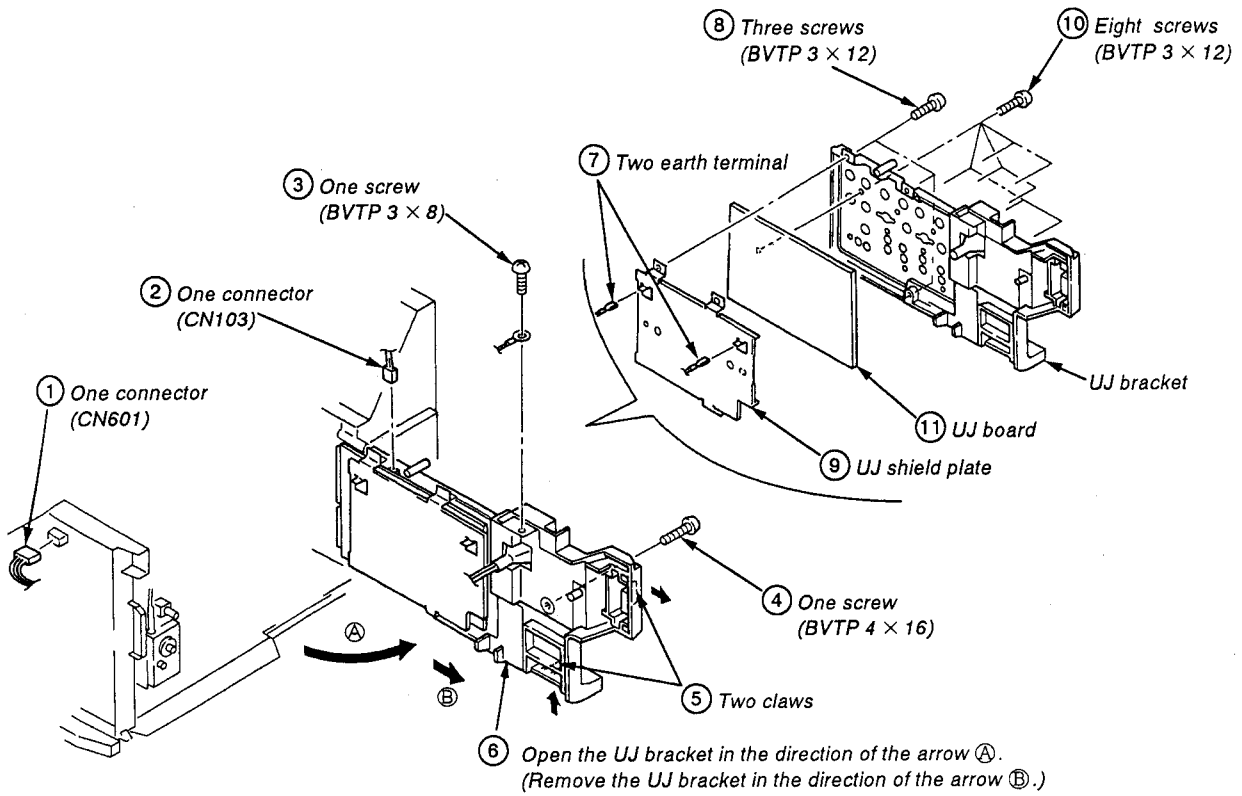

2-7. G1 BOARD REMOVAL

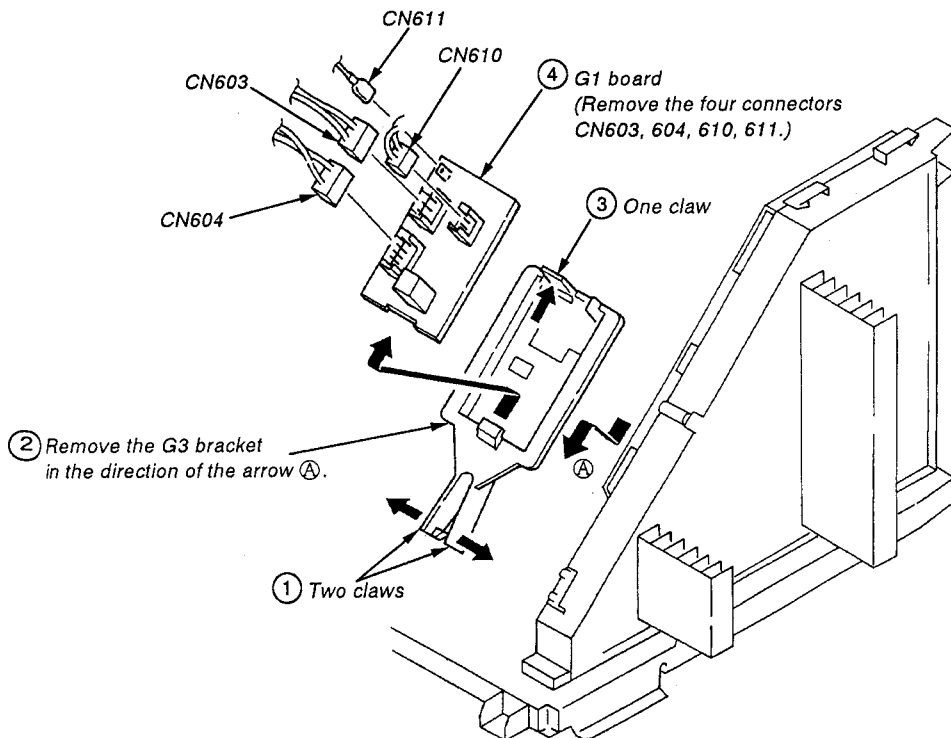

2-8. G BOARD REMOVAL

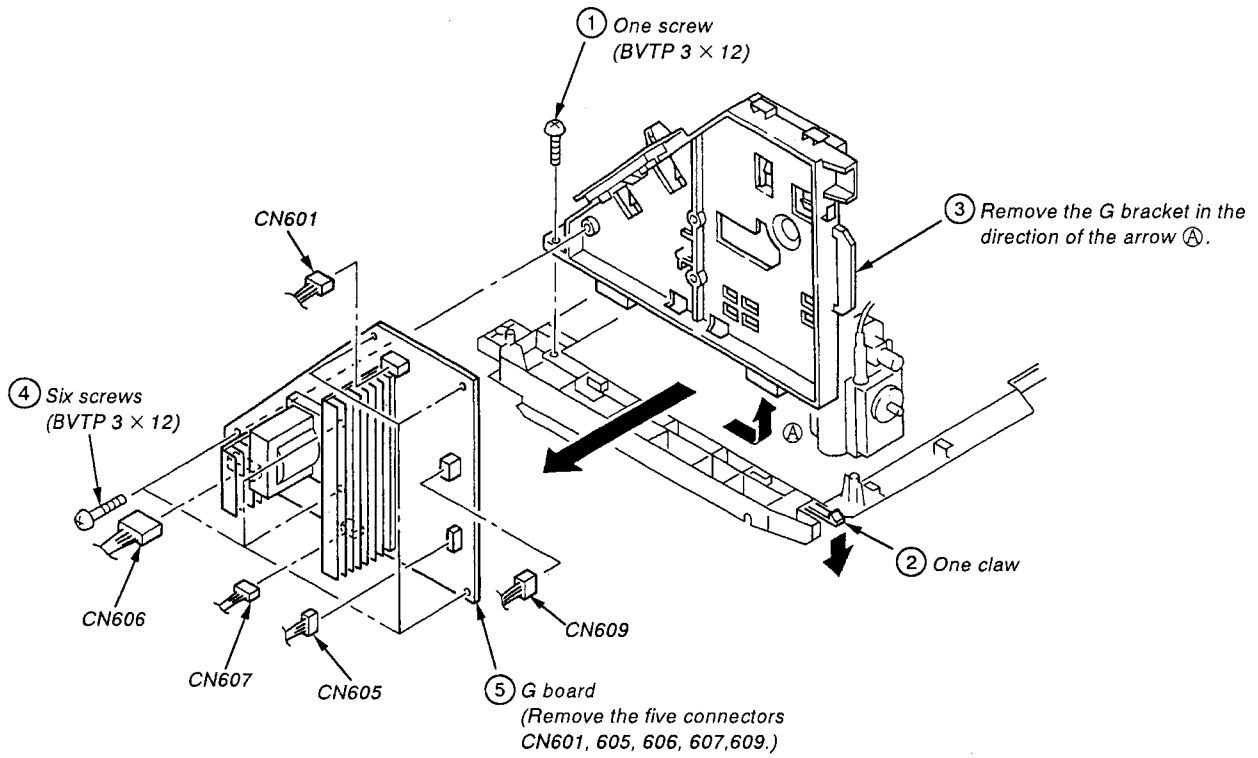

2-9. UT BOARD REMOVAL

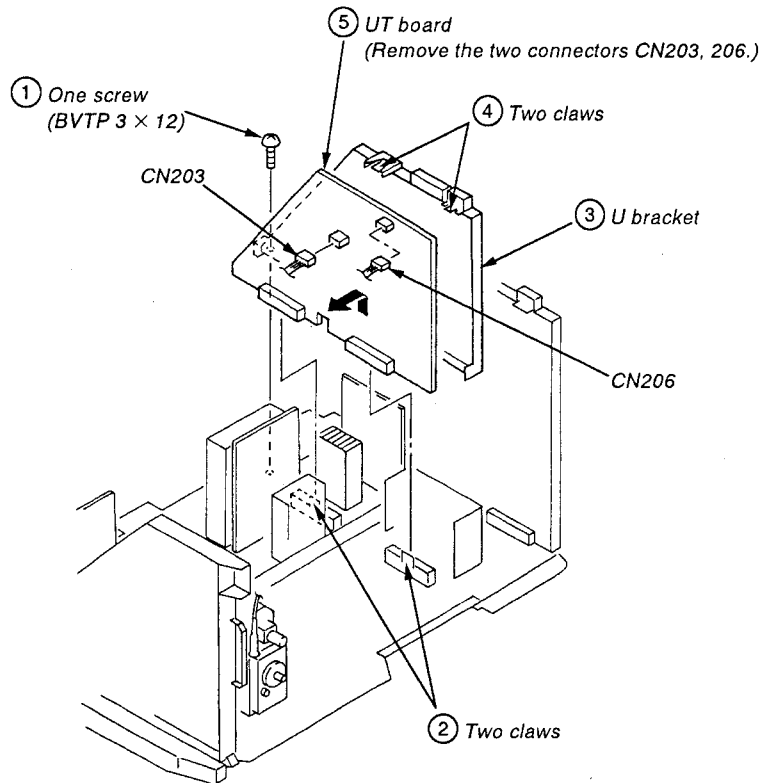

2-10. A BOARD REMOVAL

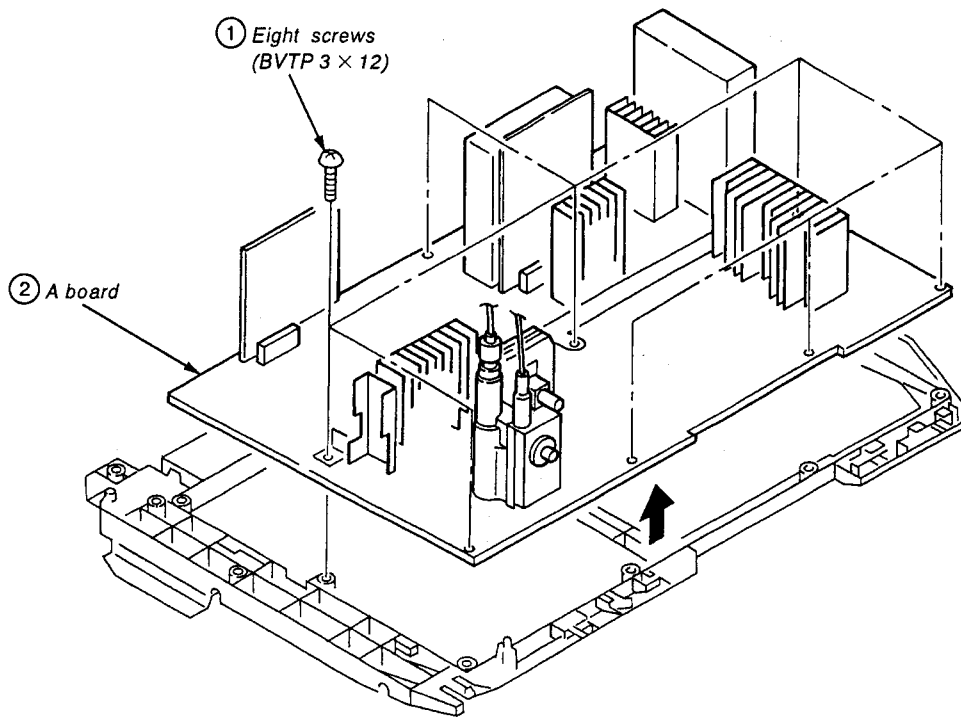

2-11. EXTENSION CABLE

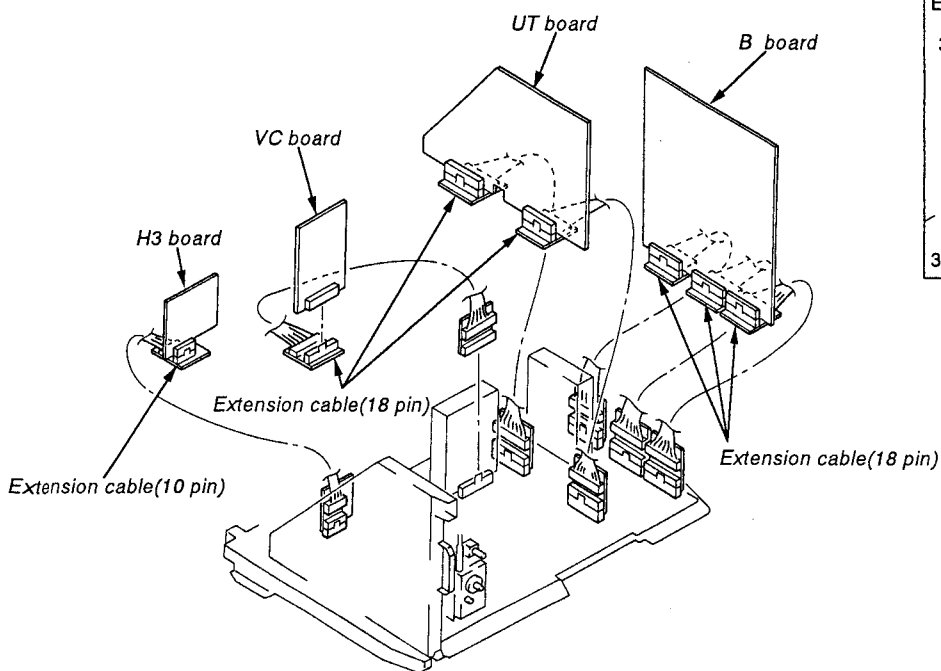

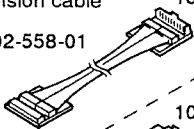
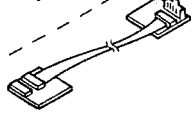
Service tool	
Extension cable	18 pin
3-702-558-01	
	10 pin
3-702-557-01	

2-12. EXTENSION BOARD

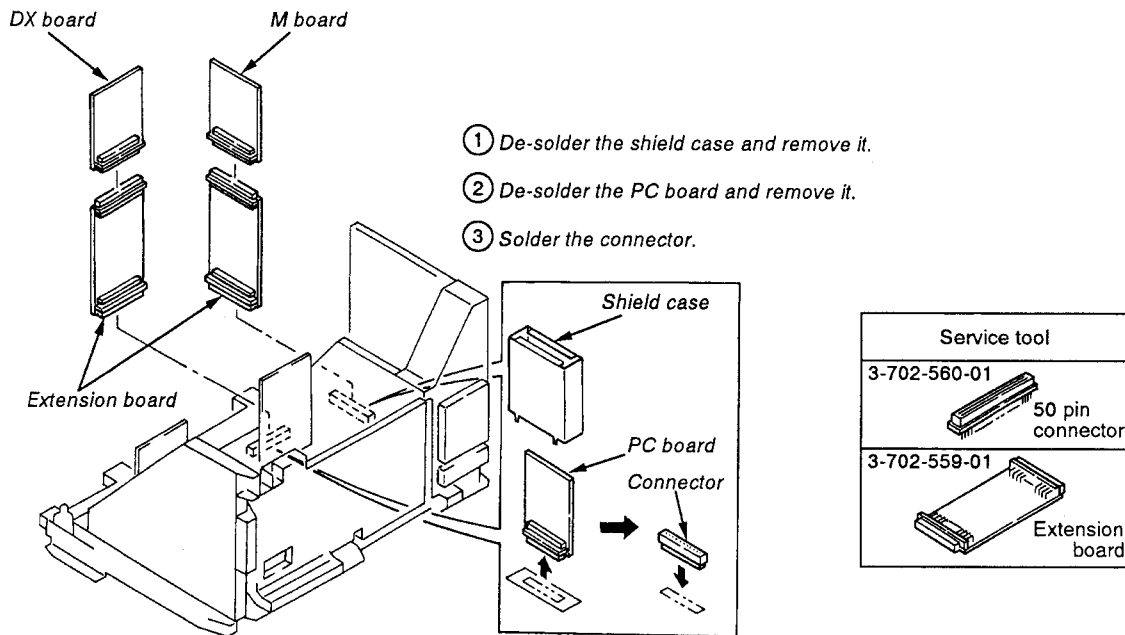

2-13. KEY BOARD UNIT AND BLIND PANEL REMOVAL

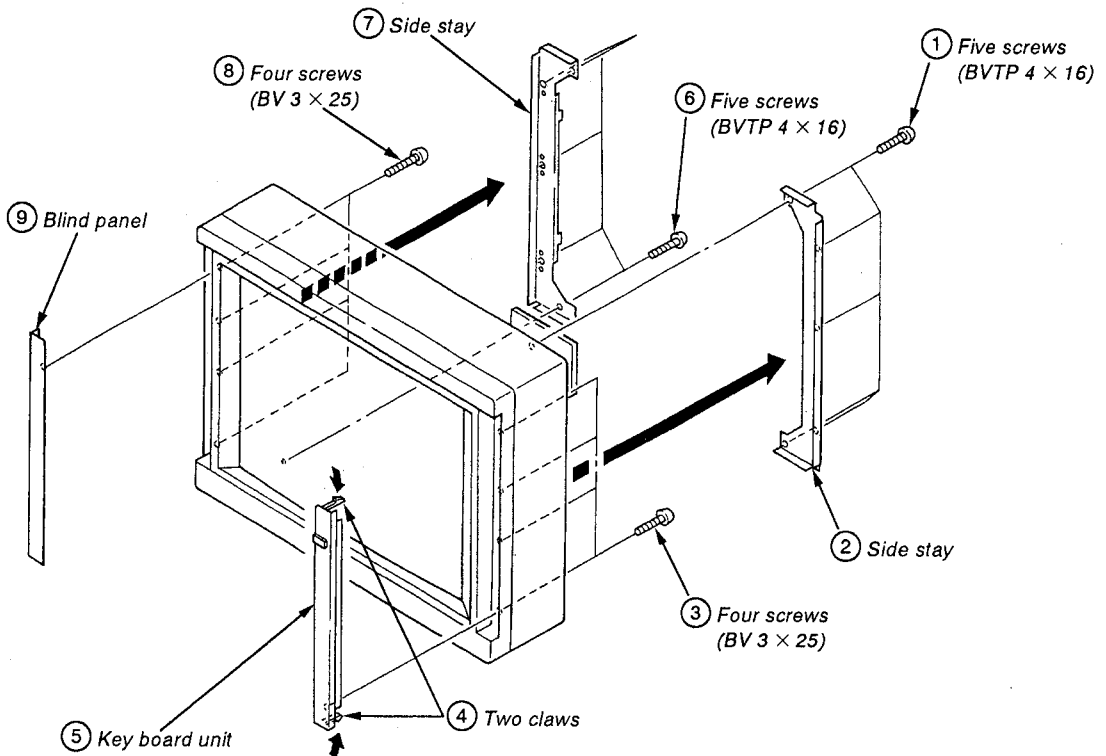

2-14. DEGAUSSING COIL REMOVAL

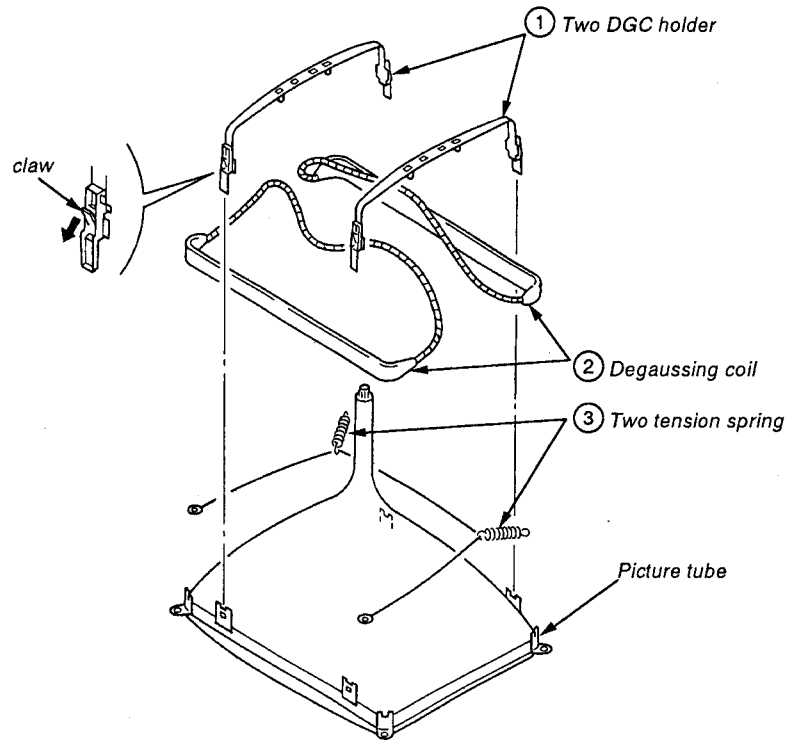

2-15. PICTURE TUBE REMOVAL

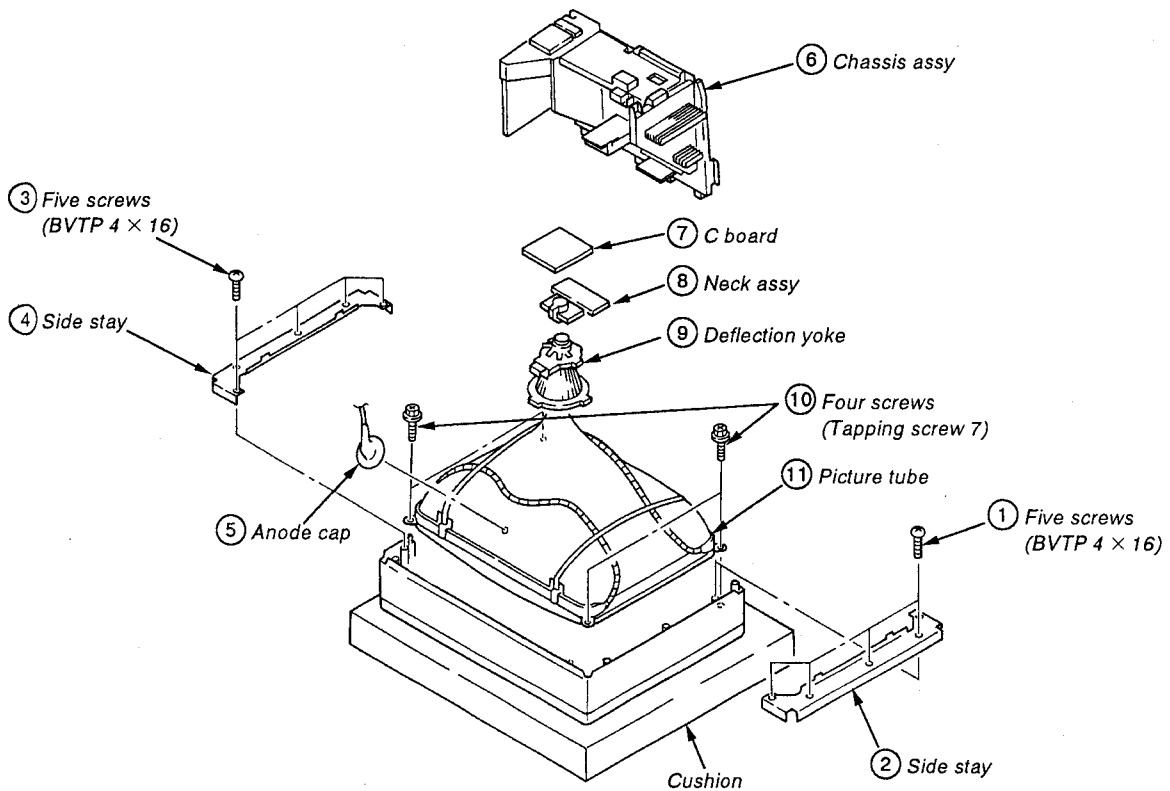

2-16. HARNESS LOCATION
(1) TOP VIEW (RIGHT)

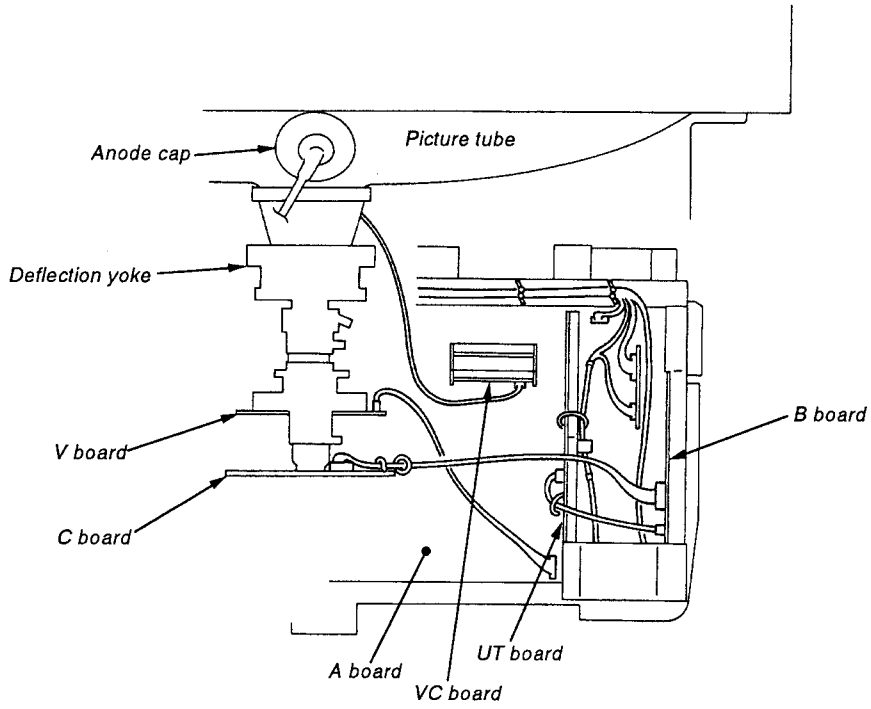

(2) TOP VIEW (LEFT)

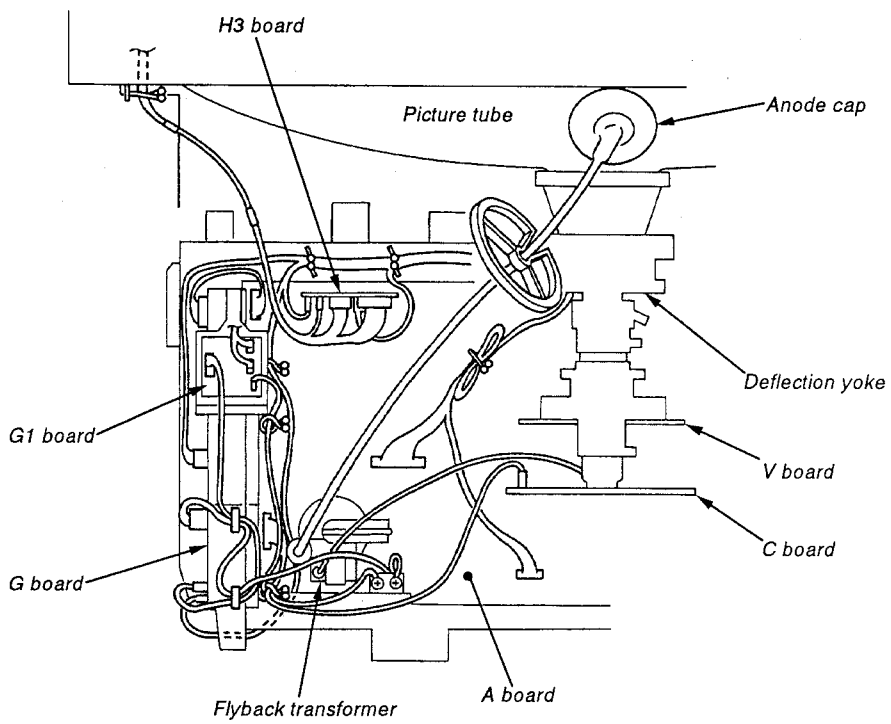

(3) LEFT SIDE VIEW

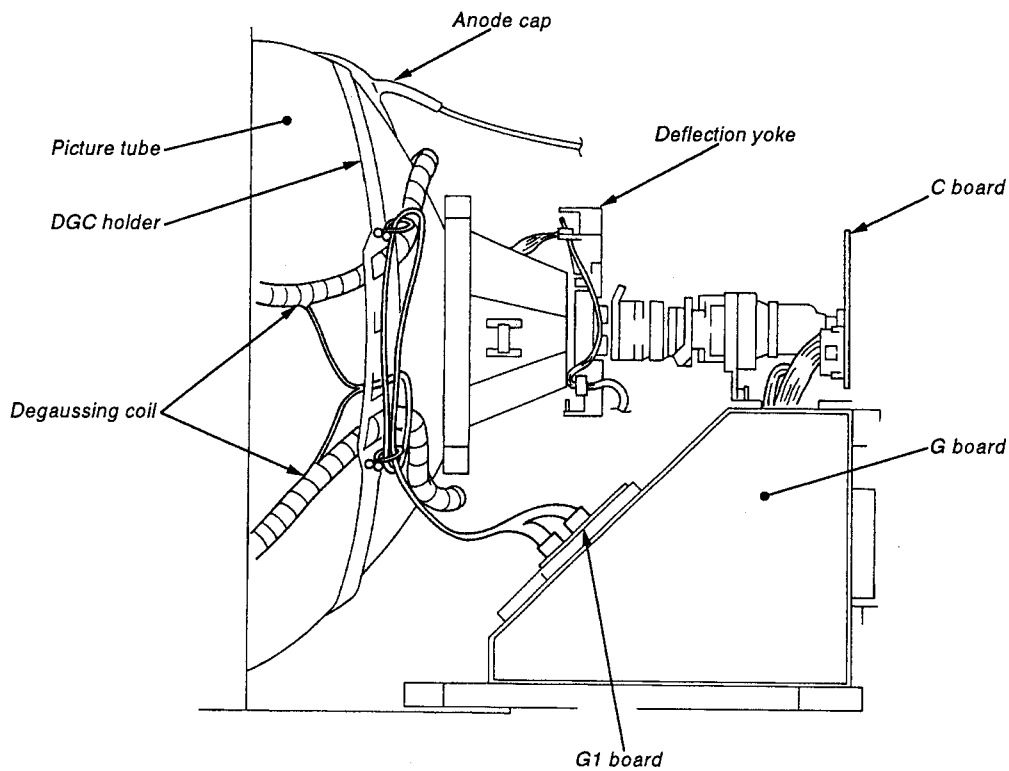

• REMOVAL OF ANODE-CAP

Note: Short circuit the anode of the picture tube and the anode cap to the metal chassis, CRT shield, or carbon painted on the CRT, after removing the anode.

• REMOVING PROCEDURES

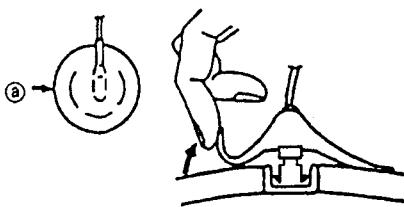

① Turn up one side of the rubber cap in the direction indicated by the arrow (a).

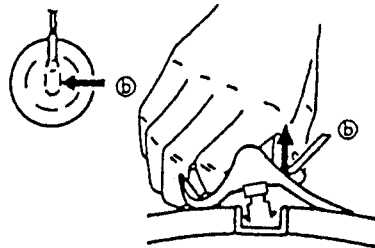

② Using a thumb pull up the rubber cap firmly in the direction indicated by the arrow (b).

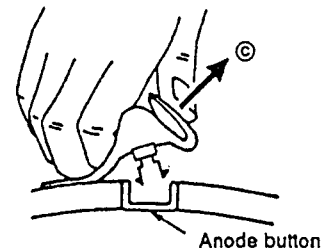

③ When one side of the rubber cap is separated from the anode button, the anode-cap can be removed by turning up the rubber cap and pulling up it in the direction of the arrow (c).

• HOW TO HANDLE AN ANODE-CAP

- ① Don't hurt the surface of anode-caps with sharp shaped material!
- ② Don't press the rubber hardly not to hurt inside of anode-caps!
A metal fitting called as shatter-hook terminal is built in the rubber.
- ③ Don't turn the foot of rubber over hardly!
The shatter-hook terminal will stick out or hurt the rubber.

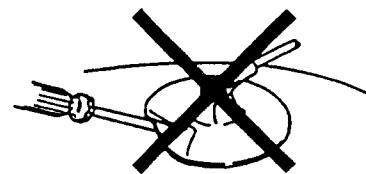
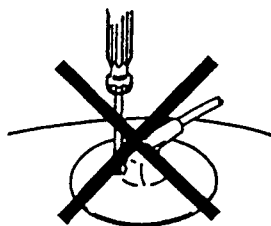

SECTION 3 SET-UP ADJUSTMENTS

- Carry out the following adjustments when readjustment is required or when attaching a new picture tube.
 - These adjustments should be carried out at rated power supply voltage unless otherwise specified.
- Controls and switches should be set in standard position as listed below unless otherwise specified.
- Contrast Standard
 Brightness Standard

3-1. BEAM LANDING

Preparations

1. Face the picture tube screen of the set in an eastward or westward direction to reduce the influence of earth magnetism.
2. Turn the power switch on the set to ON to carry out demagnetizing.

(1) Adjustment of the Y separation axis correction magnet.

1. Receive the image of the crosshatch.
2. Adjust the picture to minimum and the brightness to standard.
3. Secure the neck assembly to the position shown in the figure (Fig. 3-2).
4. Move the DY until it comes in contact with the CRT and set it in a upright position.
5. Open and close the Y separation axis correction magnet on the neck assembly until there is up-down symmetry and adjust so that the upper and lower pins are symmetrical.
6. Return the DY to the original position.

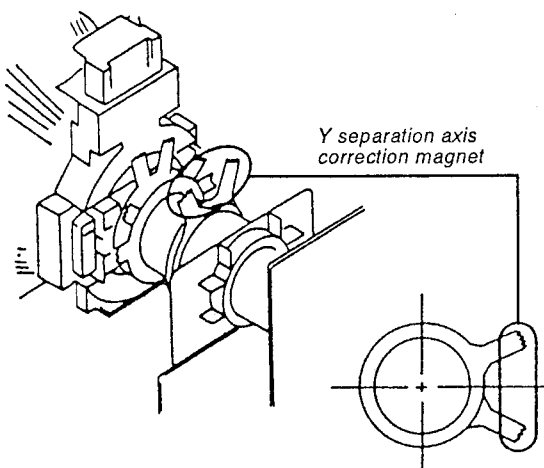

Fig. 3-1

Carry out adjustments in the following order.

- 3-1 Landing adjustment (Beam Landing)
- 3-2 Convergence adjustment
- 3-3 Focus adjustment
- 3-4 White balance adjustment

Note: Instruments used

1. Color bar/pattern generator
2. Degausser

(2) Landing

1. Receive the all-white signal of the pattern generator, adjusting the picture to maximum and the brightness to a level that is easy to view.
2. Carry out rough adjustment of the focus and horizontal convergence.
3. Loosen the retention device on the deflection yoke and adjust the purity adjustment knob in the center (Fig. 3-1).
4. Switch the pattern generator to the single color green.
5. Slide the deflection yoke to the back so that the center of the screen is green and use the purity magnet to achieve left-right symmetry (Fig. 3-3).
6. Slide the deflection yoke to the front so that the entire screen is the single color green.
7. Switch the pattern generator to the single colors red and blue and confirm that landing has been obtained.
8. Secure the retention device once the deflection yoke position has been determined.
9. If landing has not been obtained in the corner section, use the magnet to make corrections (Fig. 3-4).

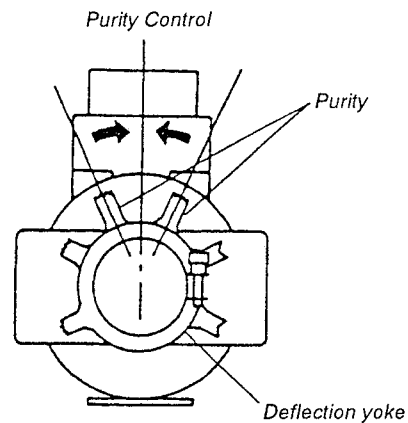

3-2. CONVERGENCE ADJUSTMENT

(1) Screen Center Convergence Adjustment

(Static Convergence)

1. Receive the dot signal and adjust the picture to standard.
2. Use the horizontal static convergence knob to arrange the red, green and blue dots on top of each other in a horizontal direction in screen center.
3. Use the vertical static convergence magnet to arrange the red, green and blue dots on top of each other in a vertical direction in screen center.

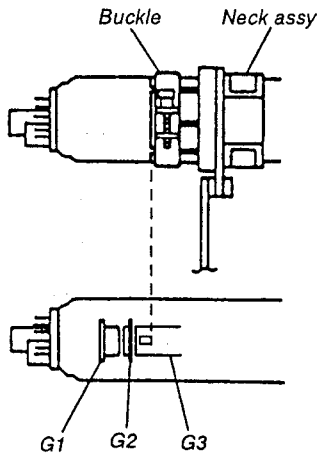

Fig. 3-2

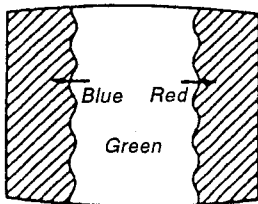

Fig. 3-3

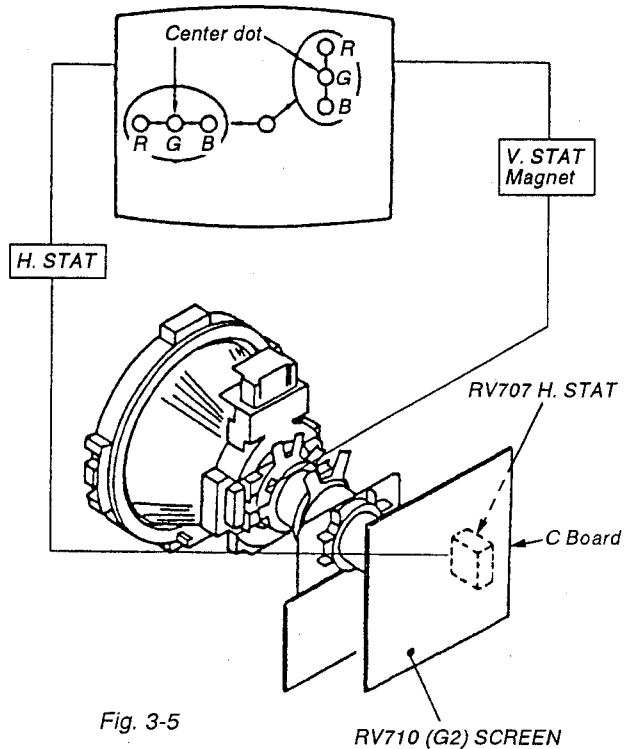

Fig. 3-5

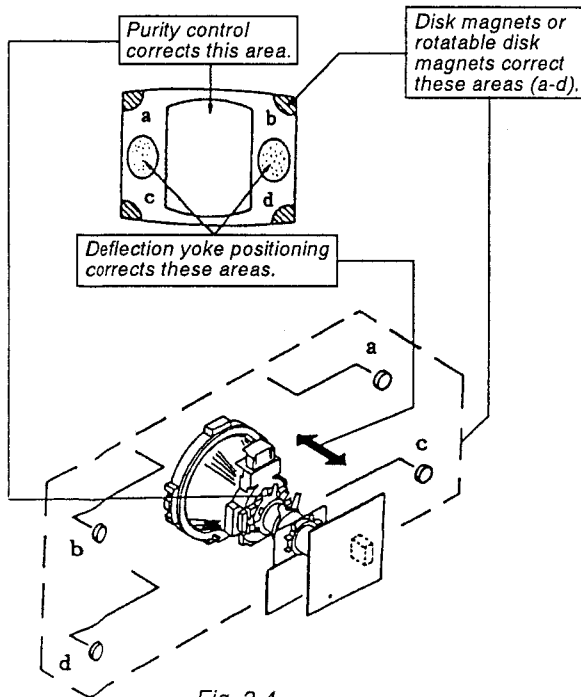

Fig. 3-4

※ If the dots do not become arranged in a horizontal direction within the adjustment range for the horizontal static convergence knob, simultaneously use the vertical static convergence magnet to adjust while taking tracking. (Incline the vertical static convergence and adjust by opening and closing the knob.)

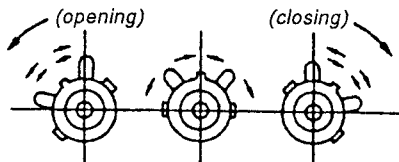

Fig. 3-6

4. Movement of the red, green and blue dots by inclination and opening/closing of the vertical static convergence magnet.

(1) Movement when opening and closing the vertical static convergence magnet.

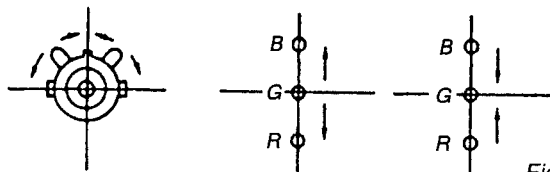

Fig. 3-7

(2) Movement when inclining the vertical static convergence magnet in a counter-clockwise direction.

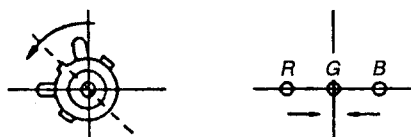

Fig. 3-8

(3) Movement when inclining the vertical static convergence magnet in a clockwise direction.

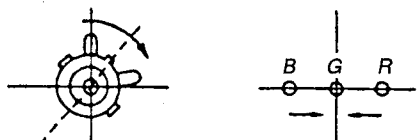

Fig. 3-9

(4) Movement when inclining the vertical static convergence magnet and opening and closing.

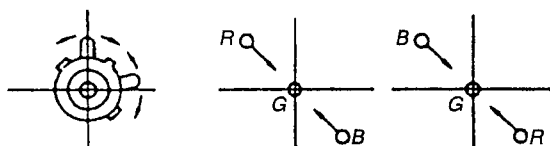

Fig. 3-10

※ If the blue dots do not line up in relation to the red and green dots, correct with the BMC (6-pole) magnet.

5. Correction of HMC (horizontal misconvergence) and VMC (vertical misconvergence) with the BMC (6-pole) magnet.

(1) HMC correction with the BMC (6-pole) magnet and movement of the electron beam.

HMC correction (A)

HMC correction (B)

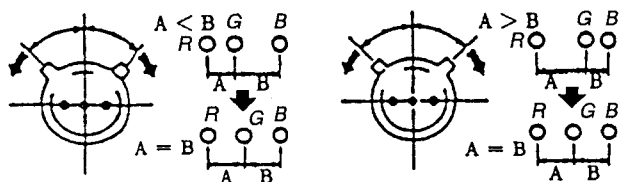

Fig. 3-11

(2) VMC correction with the BMC (6-pole) magnet and movement of the electron beam.

VMC correction (A)

VMC correction (B)

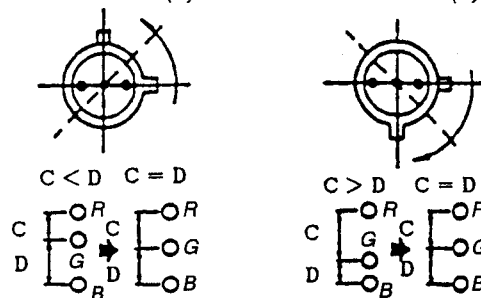

Fig. 3-12

Position of the knob

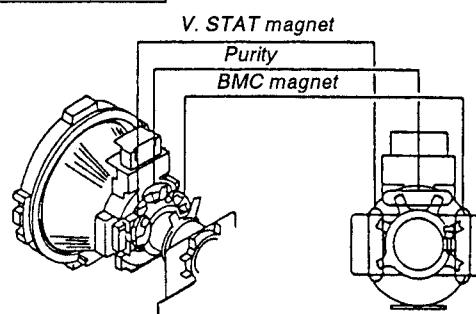

Fig. 3-13

(2) Convergence Adjustment on the Screen Periphery (Dynamic Convergence)

1. Use the horizontal static convergence VR (H.STAT) to adjust the convergence in a horizontal direction in screen center.
2. Change to the service mode and carry out the following dynamic convergence adjustments.

(Service Mode : Use the remote control to press the following buttons in succession : **Screen display** → **CH5** → **Volume +** → **Power** .

please refer to page 27 for selecting the item on how to adjust the dynamic convergence.

	Adjustment Items	Adjustment Range
01	DC SHIFT (H. STAT)	000-063
02	H. AMP	000-063
03	H. TILT	000-063
04	UP. Y. BOW	000-063
05	UP. C. BOW	000-063
06	UP. TILT	000-063
07	LO. Y. BOW	000-063
08	LO. C. BOW	000-063
09	LO. TILT	000-063

3. Press **1** and **4** on the remote control to select the items. Adjust with the **3** and **6** buttons.

1) Y.BOW adjustment on the upper side of the screen (UP.Y.BOW).

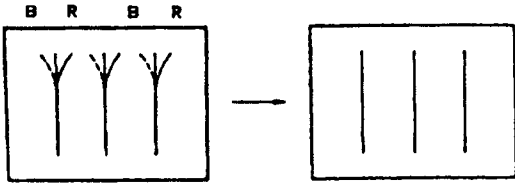

Fig. 3-14

2) Y.BOW adjustment on the lower side of the screen (LO.Y.BOW)

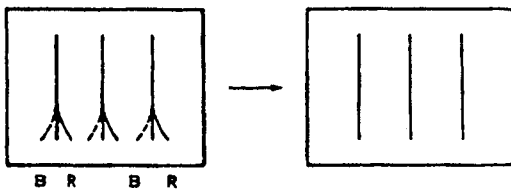

Fig. 3-15

3) H.AMP adjustment (HAMP).

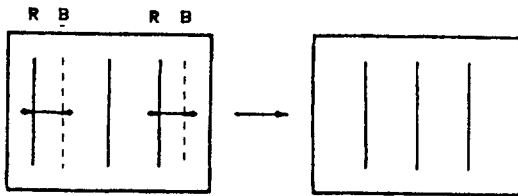

Fig. 3-16

4) TILT adjustment (HTLT)

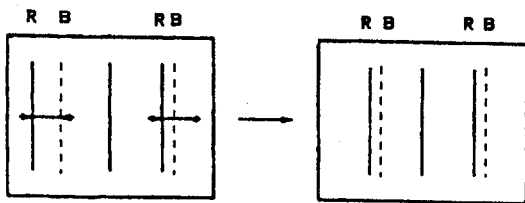

Fig. 3-17

5) C.BOW adjustment on the upper side of the screen (UP.C.BOW).

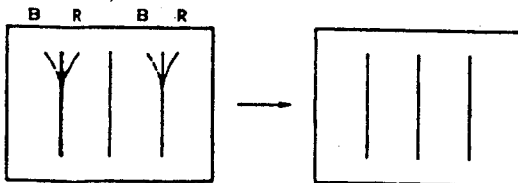

Fig. 3-18

6) TILT adjustment on the upper side of the screen (UP.TILT).

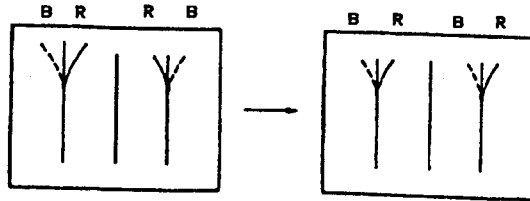

Fig. 3-19

7) C.BOW adjustment on the lower side of the screen (LO.C.BOW).

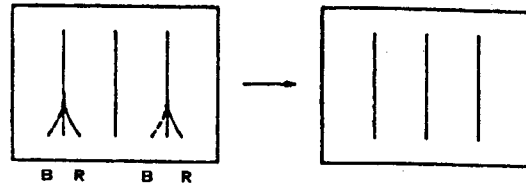

Fig. 3-20

8) TILT adjustment on the lower side of the screen (LO.TILT).

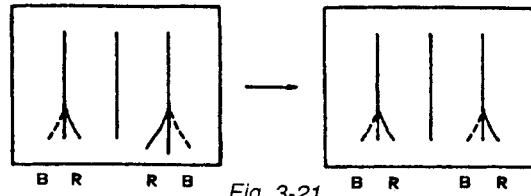

Fig. 3-21

4. If there is a misconvergence in the corner section of the screen, use permalloy to adjust.

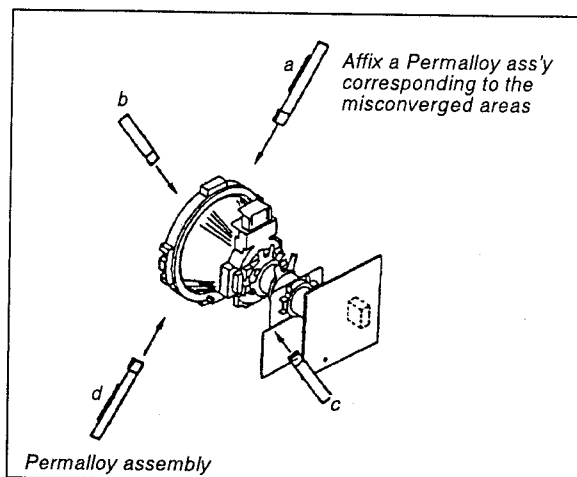
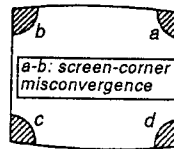

Fig. 3-22

3-3. FOCUS ADJUSTMENT

1. Receive a broadcast.
2. Adjust the picture to standard condition.
3. Adjust the focus volume of the flyback transformer until the focus is ideal in the center of the screen. If the focus is adjusted only to the center of the screen, a magenta ring will appear on the screen. In such a case adjust the focus so that is even on all parts of the screen.

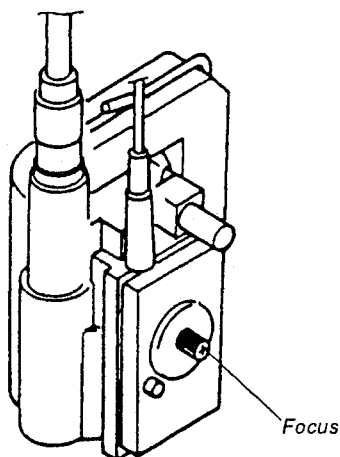

Fig. 3-23

3-4. SCREEN (G2) WHITE BALANCE ADJUSTMENT

G2 Adjustment (RV710)

1. Adjust the picture and brightness to standard.
2. Connect an oscilloscope to the cathode.
3. Remove CN305 connect pin 1, 2, 3 to an external power supply and adjust the cathode voltage to $176 \pm 2V$.
4. Adjust RV710 (G2) by adjusting to a position that is just prior to disappearance of the flyback line on the screen.

WHITE BALANCE ADJUSTMENT

(Caution ; Refer to Page 38)

1. Input the gray scale to Line 1 and select 9300 K on the screen menu.
2. Set so that the user control contrast is minimum and the brightness is reset.
3. Set in the service mode and adjust so that the 0 IRE of the gray scale is cut off and 10 IRE is slightly bright at a brightness of 01.
4. Change the signal to the all-white signal and change the signal level so that the center brightness is 10 nit.

Note : If fine adjustments of the brightness are not possible with the signal level, use contrast on the user control to adjust.

5. Use the G cutoff and B cutoff to adjust so that the color temperature is $9300K+8 \text{ MPCD} \pm 2\text{JND}$.
6. Set the all-white signal level to 100 IRE.
7. Use the G drive and B drive to adjust so that the color temperature is $9300K+8 \text{ MPCD} \pm 2\text{JND}$.
8. Adjust the brightness to 10 nit and confirm that the color temperature is $9300K+8 \text{ MPCD} \pm 2\text{JND}$. Repeat steps 3 to 7 to adjust when necessary.
9. Return to step (1) and check whether the brightness has altered. If so, repeat steps 1-8 to adjust.

10. Input the gray signal of the Y color difference signal to Line 3.
11. Change the signal level so that the center brightness is 10 nit.
12. Adjust the G cutoff and B cutoff so that the color temperature is $9300K+8 \text{ MPCD} \pm 2\text{JND}$.
13. Change the input to the RGB mode of Line 3 and input the RGB gray signal.
14. Change the signal level so that the brightness in screen center is 10 nit.
15. Adjust the G cutoff and B cutoff so that the color temperature is $900K+8 \text{ MPCD} \pm 2\text{JND}$.
16. Save the adjustment data.
17. Change the input to Line 1, change the signal to the gray scale and go to the 6500K mode on the screen menu.
18. Carry out the same adjustments as in steps 2 to 8 so that the color temperature is $6500K+8 \text{ MPCD} \pm 2\text{JND}$.
19. Save the adjustment data.
20. Change the input to the component mode of Line 3 and input the gray signal of the Y color difference signal.
21. Carry out exactly the same adjustments as in 11 and 12 so that the color temperature is $6500K+8 \text{ MPCD} \pm 2\text{JND}$.
22. Save the adjustment data.
23. Change the input to the RGB mode of Line 3 and input the RGB gray signal.
24. Carry out exactly the same adjustments as in 14 and 15 so that the color temperature is $6500K+8 \text{ MPCD} \pm 2\text{JND}$.
25. Save the adjustment data.
26. Change the input to Line 1, change the signal to the gray scale and go to the 3200K mode on the screen menu.
27. Carry out exactly the same adjustments as in steps 2 to 8 so that the color temperature is $3200K \pm 2\text{JND}$.
28. Save the adjustment data.
29. Change the input to the component mode of Line 3 and input the gray signal of the Y color difference signal.
30. Carry out exactly the same adjustments as in steps 11 and 12 so that the color temperature is $3200K \pm 2\text{JND}$.
31. Save the adjustment data.
32. Change the input to the RGB mode of Line 3 and input the gray signal of RGB.
33. Carry out exactly the same adjustments as in steps 14 and 15 so that the color temperature is $3200K \pm 2\text{JND}$.
34. Save the adjustment data.
35. Input a window signal of 100 IRE from Line 1 and go to the 9300K mode. In addition, set the contrast and brightness of the user control to the reset state.
36. Adjust with the picture control until the brightness at the center of the tube is $200 \pm 10 \text{ nit}$.
37. Save the adjustment data.
38. Change to the 6500K mode.
39. Adjust the picture adjustment so that the brightness at the center of the tube is $200 \pm 10 \text{ nit}$.
40. Save the adjustment data.
41. Change to the 3200K mode.
42. Adjust the picture adjustment so that the brightness at the center of the tube is $140 \pm 10 \text{ nit}$.
43. Save the adjustment data.

SECTION 4 SAFETY RELATED ADJUSTMENTS

CONFIRMATION OF HOLD-DOWN(☒ R583)

Be sure to carry out the following adjustments after replacing the following parts (indicated with a ☒ sign in the circuit chart).

- ☒ C574, D515, IC501, IC620, Q517, Q518, R578, R580, R581, R582, R583, R584, R585, T504

- (1) Confirmation of B + line.
 1. Input a voltage of 130 ± 0.1 VAC and set picture and brightness to minimum level.
 2. Confirm that the voltage on the B+ line is 135.6VDC or less when receiving the dot signal.
- (2) Confirmation of hold-down operation
 1. Set the power source voltage to AC120V and receive the all-white signal.
 2. Adjust the picture and the brightness so that IABL is 1610 ± 50 μ A.
 3. Confirm that the hold-down circuit operates and the raster disappears at a voltage of DC 147.3V or less when applying voltage from external DC power source to the ② pin of IC501.

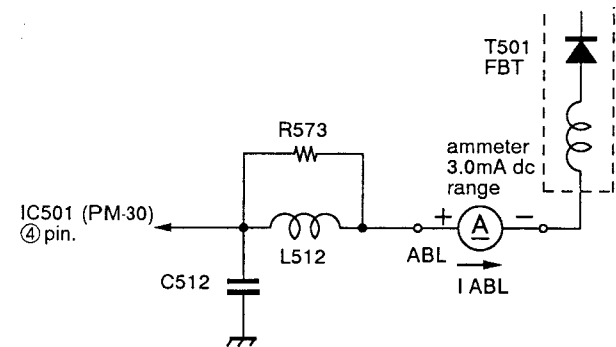

(US, Canadian Model)

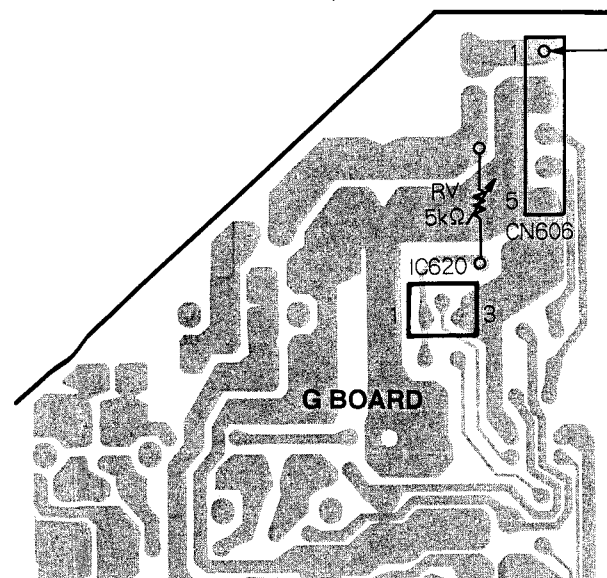

(AEP, AUS Model)

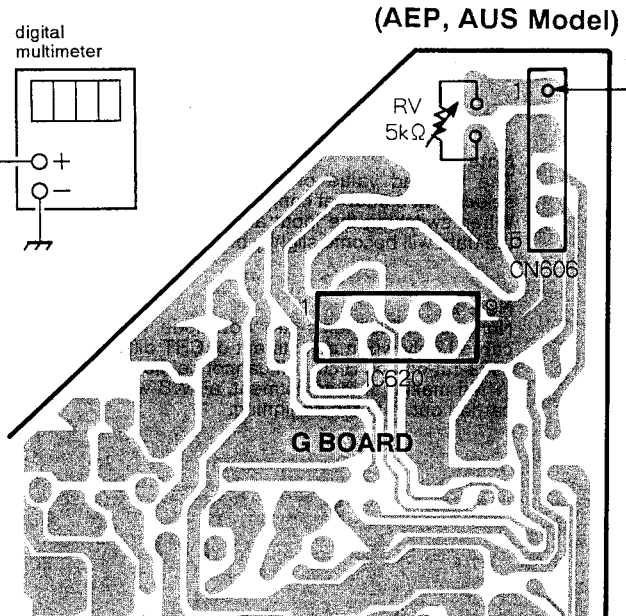

CONFIRMATION OF HOLD-DOWN(☒ R581)

Be sure to carry out the following adjustments after replacing the following parts (indicated with a ☒ sign in the circuit chart).

- ☒ C574, D515, IC501, IC620, Q517, Q518, R578, R580, R581, R582, R583, R584, R585, T504

- (1) Tertiary winding detection
 1. Set the power source voltage to AC120V and receive the all-white signal.
 2. Adjust the picture and brightness so that IABL is 1610 ± 50 μ A.
 3. Confirm that the hold-down circuit operates and the raster disappears at a voltage of DC147.9V or less when applying voltage from the external DC power source to the ① pin of IC501 on substrate A.

CONFIRMING THE +B VOLTAGE

The following confirmations must be carried out when replacing IC620.

1. Input $AC130 \pm 0.1$ V 60 Hz as the input voltage to the power source section.
2. Receive the dot signal and set CONT and BRT to MIN. At this time the voltage on the +B line should be 135.6 V or less.

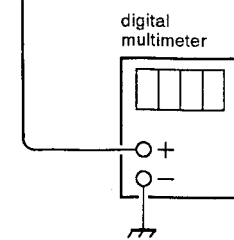
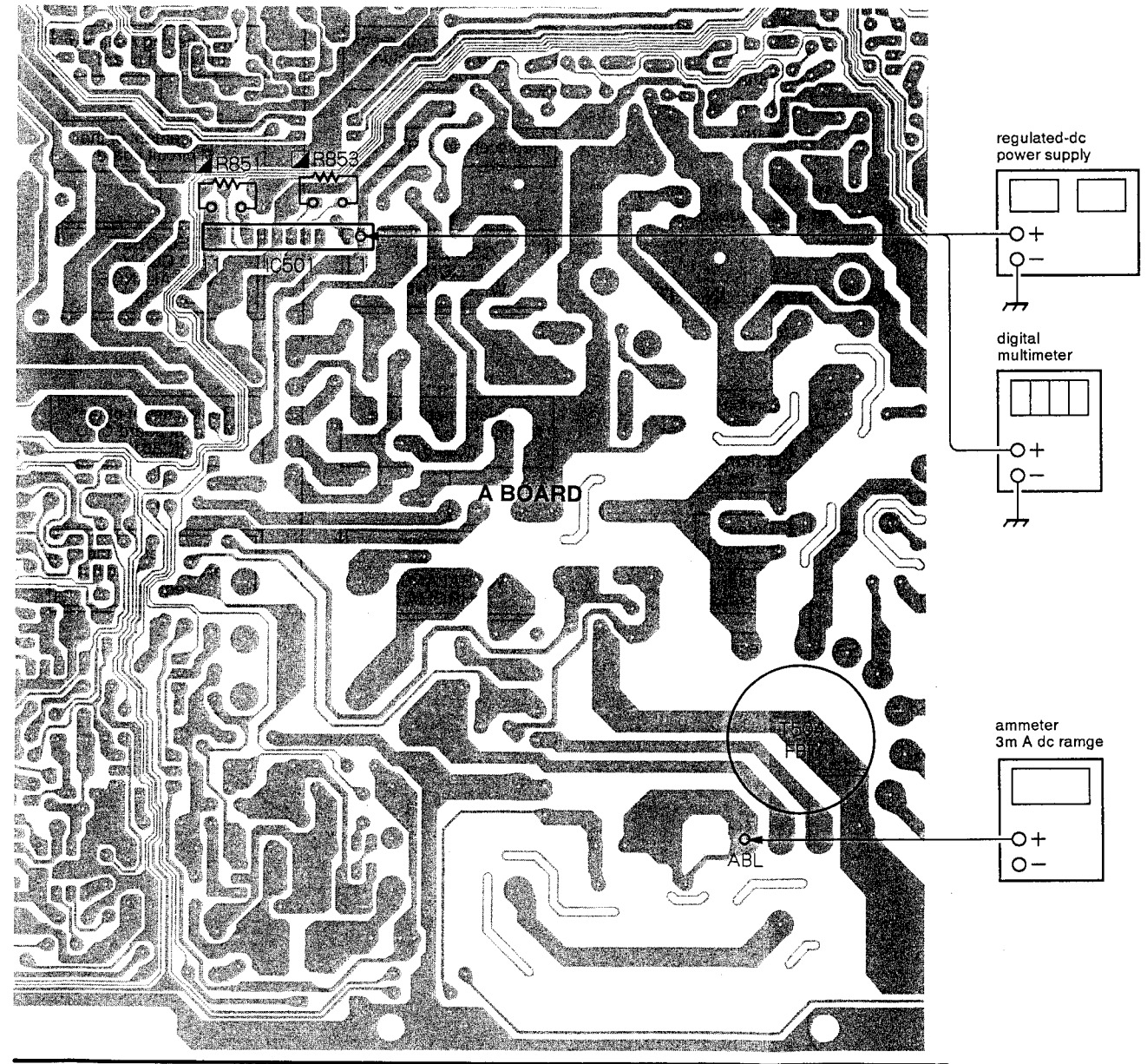

SECTION 5 ELECTRIC ADJUSTMENT IN THE SERVICE MODE

Electric adjustment can be carried out with the remote commander provided with the set (RM-854).

The places to be adjusted in the service mode are as follows.

RESET U MEN.....All user controls shall be preset.
GEO DEST.....Adjustment of screen distortion
D CONV.....Convergence adjustment
W BALANCE.....White balance adjustment
CHROMA.....Adjustment of the components' primary color matrix

When entering the service mode, the set shall be in standby condition, and each switch shall be pressed in the order of [Screen display → 5 → VOL+ → POWER].

FUNCTIONS OF THE COMMANDER IN THE SERVICE MODE

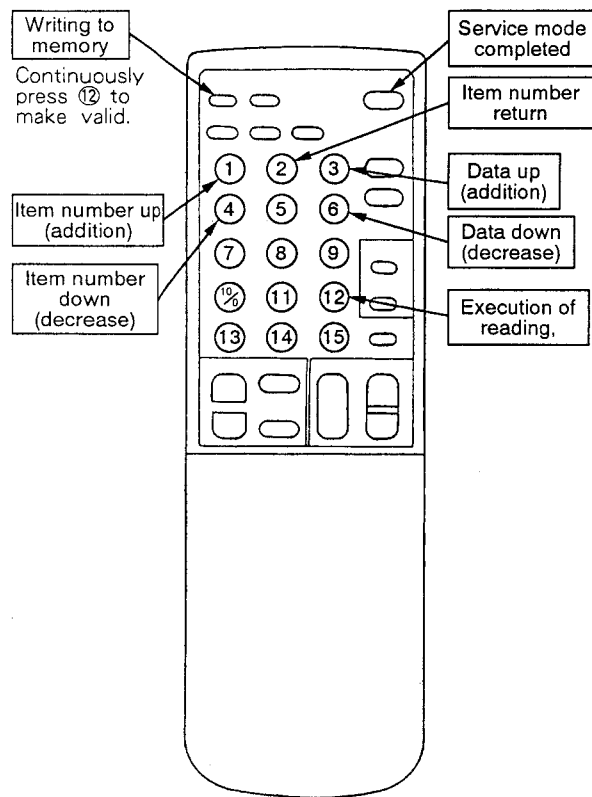

• WHEN ADJUSTMENT IS REQUIRED IN THE SERVICE MODE

When carrying out the following repairs, please be aware that adjustment in the service mode is required.

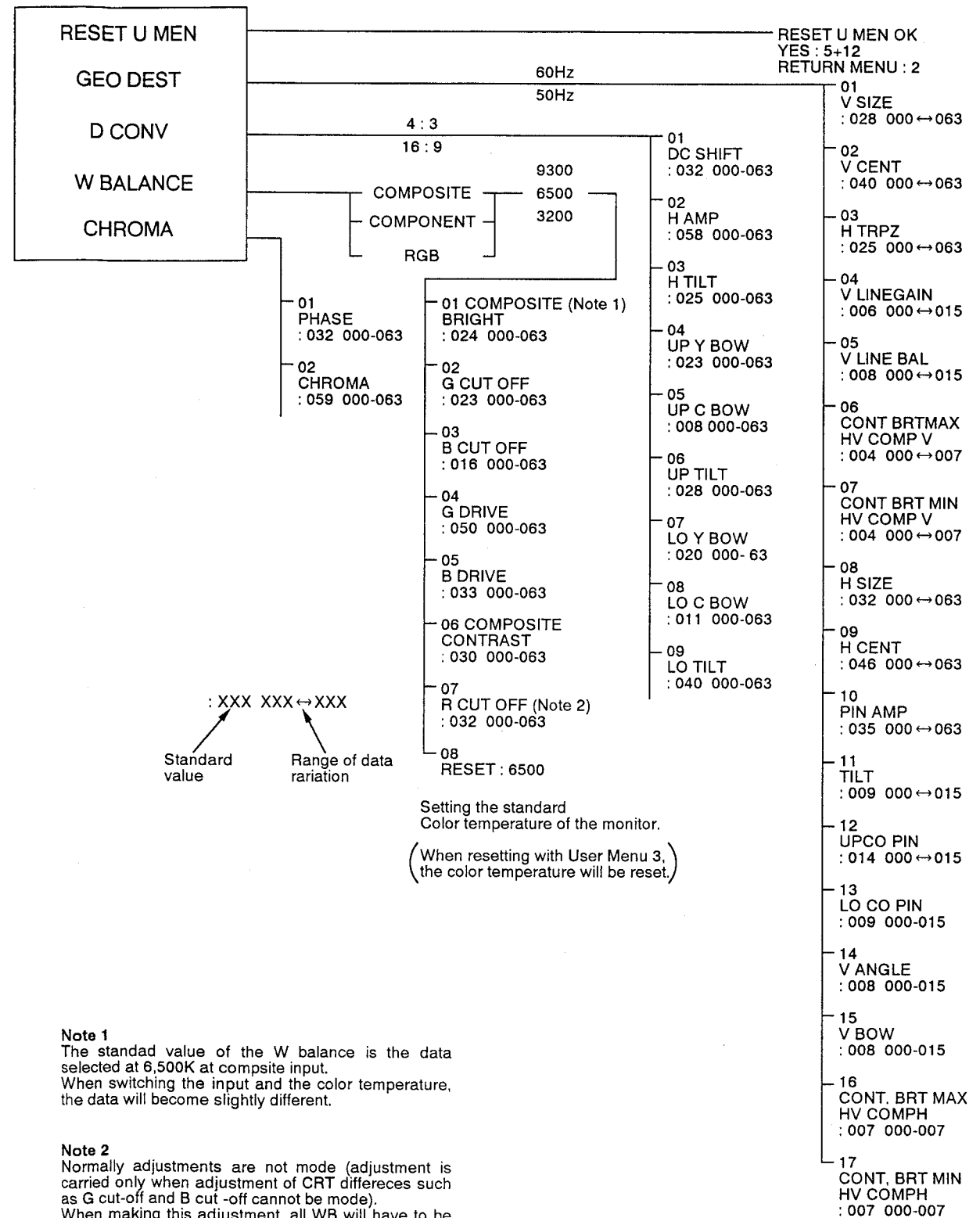
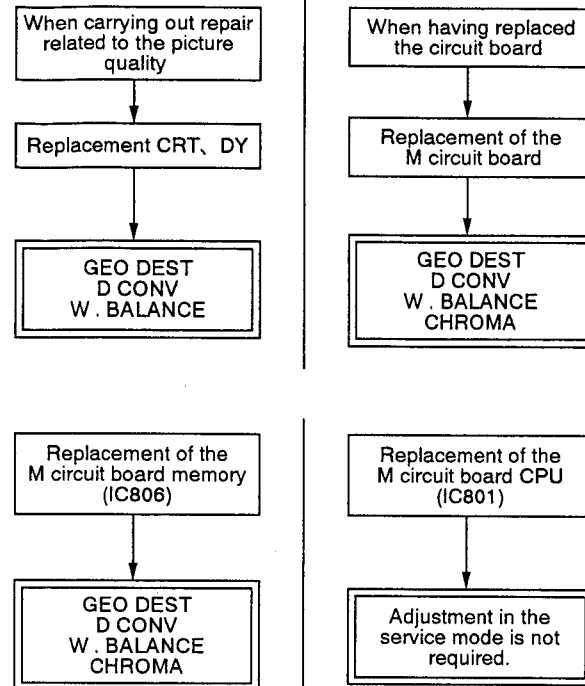

SECTION 6 CIRCUIT ADJUSTMENTS

6-1. B BOARD ADJUSTMENTS

B BOARD – CONDUCTOR SIDE –

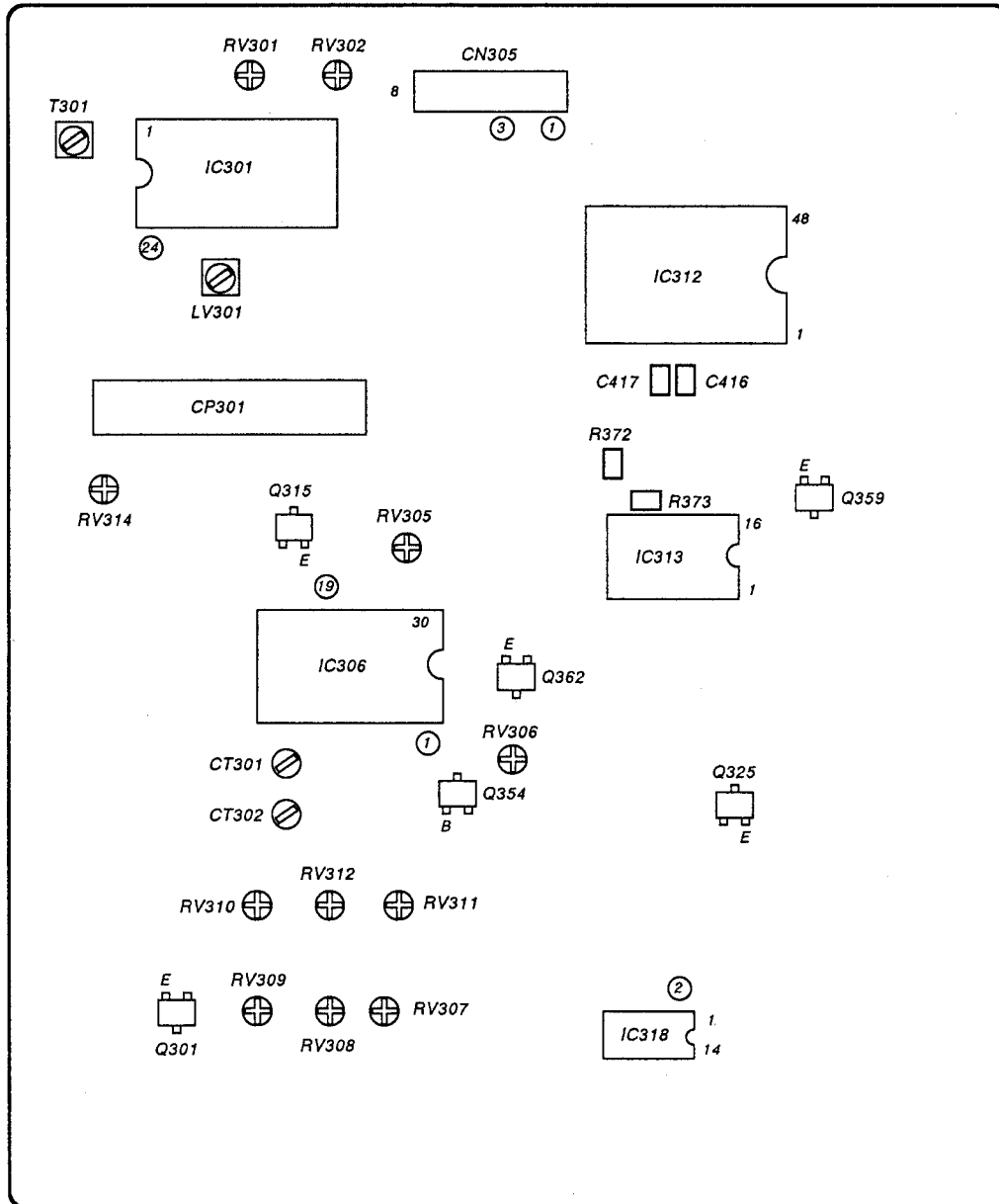

1. Call up the set menu and reset all the user control functions.
2. Connect the oscilloscope between UT board CN205 Pin ③ and ground and adjust RV201 so that the Y output is 2.0 ± 0.1 Vp-p (100% white signal).
3. Connect the oscilloscope between UT board CN205 Pin 1 and ground and adjust RV202 so that the Burst output is 200 ± 10 mVp-p (100% white signal)
4. Primary color matrix adjustment
 - 4-1. Input a component 75% color bar R-Y and sync signal to Line 3.
 - 4-2. Set service personnel mode.

- 4-3. Connect the emitter of Q359 to +12V and the emitter of Q315 to ground.
- 4-4. Connect the oscilloscope between CN305 Pin ③ and ground and adjust with the remote controller so that B-Out is 50 mVp-p max.



Fig. 6-1

- 4-5. Return Q359 and Q315 to their original connections.
- 4-6. Also input a B-Y/Y signal to Line 3. Adjust with the remote controller so that for the waveform at CN305 Pin ③ (B-Out), A=B.

5. Chroma decoder adjustment

- 5-1. Input NTSC color bars from Line 1.
- 5-2. Connect the oscilloscope to the emitter of Q325 and the emitter of Q326.
- 5-3. Connect the base of Q354 and ground.
- 5-4. Adjust RV306 so that the pulse position phase is as shown in the figure below.

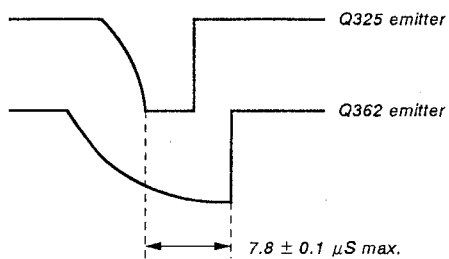

Fig. 6-2

- 5-5. Input an all-white NTSC signal to Line 1.
- 5-6. Return Q354 to its original connections.
- 5-7. Use the circuit in the figure below to supply +12 V to IC306 Pin ①.

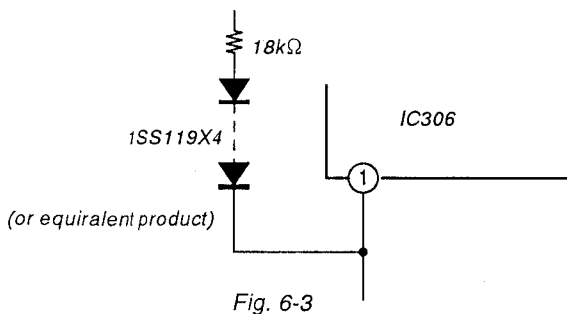

Fig. 6-3

- 5-8. Connect the emitter of Q301 to ground.
- 5-9. Connect IC318 Pin ② to ground.
- 5-10. Connect the frequency counter to IC306 Pin ⑩ and adjust CT301 so that the frequency is 3579545 ± 30 Hz.
- 5-11. Convert the signal to an all-white PAL signal.
- 5-12. Check that IC318 Pin ② is +5V.
- 5-13. Connect the frequency counter to IC306 Pin ⑩ and adjust CT302 so that the frequency is 4433619 ± 30 Hz.

6. NTSC Hue/Color Adjustment

- 6-1. Input color bars including only the burst and R-Y components from Line 1.

- 6-2. Connect the oscilloscope to the C417 ⊕ side and adjust RV308 so that the waveform is as shown in the figure below.

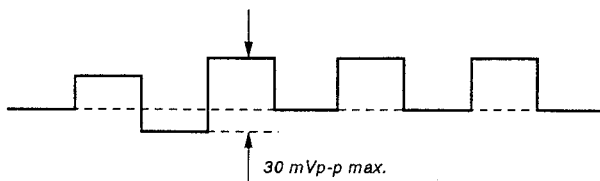

Fig. 6-4

- 6-3. Change the signal to NTSC 75% full color bars.
- 6-4. Connect the oscilloscope between C417 and R372 and adjust RV311 so that the waveform is as below.

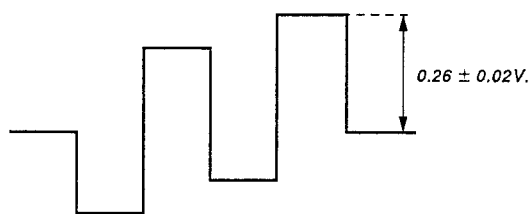

Fig. 6-5

- 6-5. Connect the oscilloscope between C416 and R373 and adjust RV305 so that the waveform is as below.

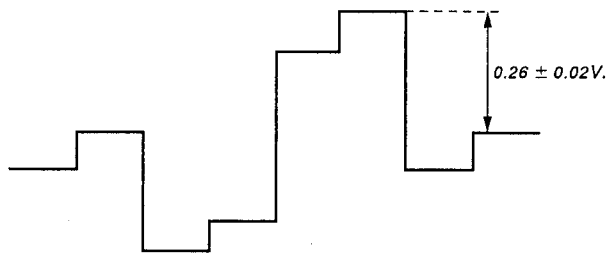
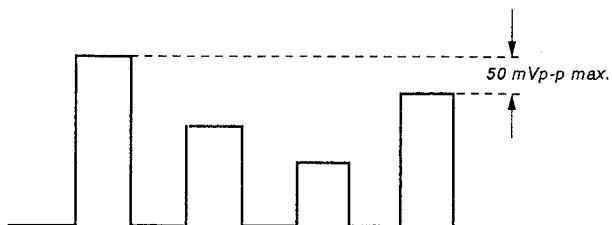

Fig. 6-6

- 6-6. Connect the oscilloscope to CN305 Pin ③ and adjust RV311 so that the waveform is as below.



Make the 1st waveform and the 4th waveform the same.

Fig. 6-7

- 6-7. Switch the signal to 4.43 NTSC 75% color bars.

6-8. Connect the oscilloscope to CN305 Pin ③. Secure the tracking and adjust with RV307 and RV310 so that the heads of the waveforms line up.

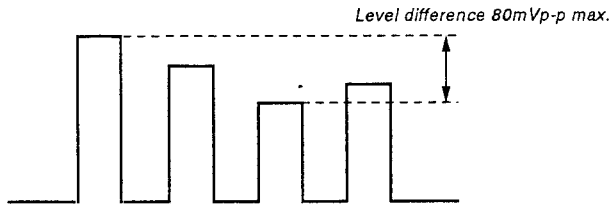

Fig. 6-8

7. PAL Color Demodulation Adjustment

7-1. Input the PAL special color bars from Line 1.

7-2. Connect the oscilloscope to C416 and R373 and adjust RV309 so that the anti-PAL signal is as in the figure below.

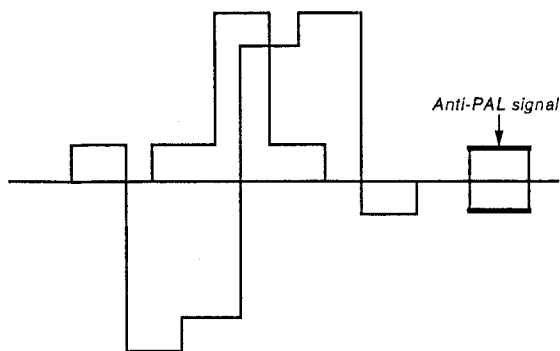
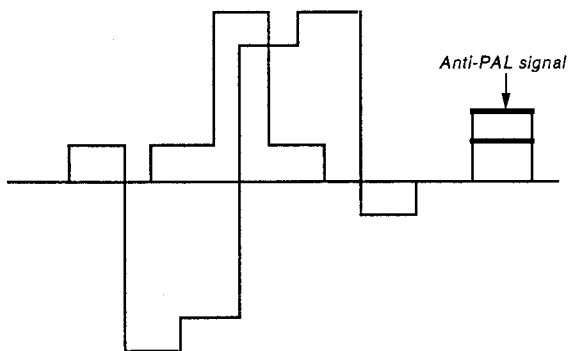

Fig. 6-9

7-3. Connect the oscilloscope to C417 and R372 and adjust RV2 on CP301 so that the anti-PAL signal is as in the figure below.

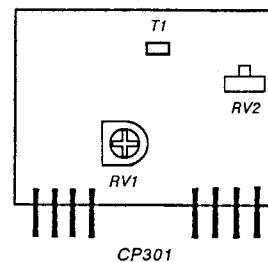
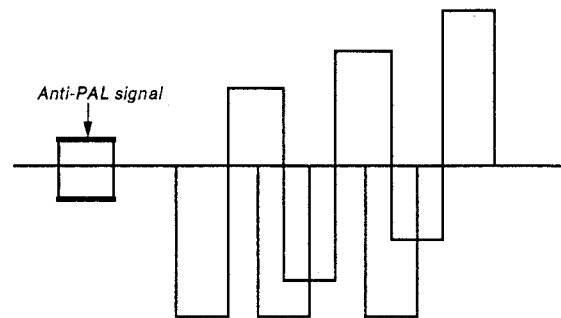
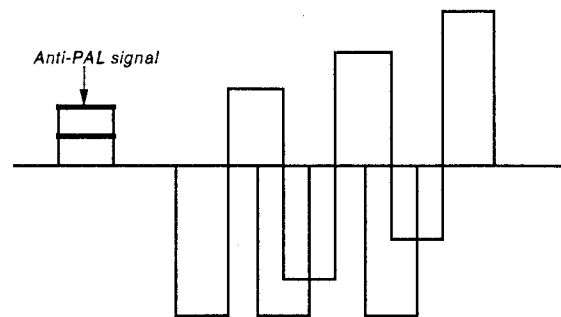

Fig. 6-10

7-5. Connect the oscilloscope to C416 and R373 and adjust RV312 so that the waveform is as in the figure below.

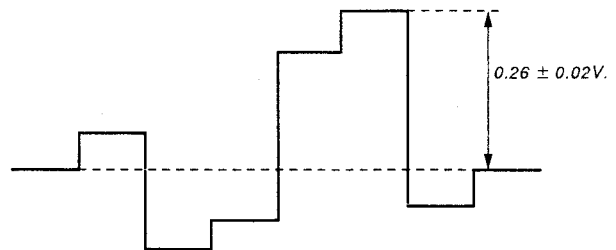

Fig. 6-11

7-6. Connect the oscilloscope to C417 and R372 and adjust RV314 so that the waveform is as in the figure below.

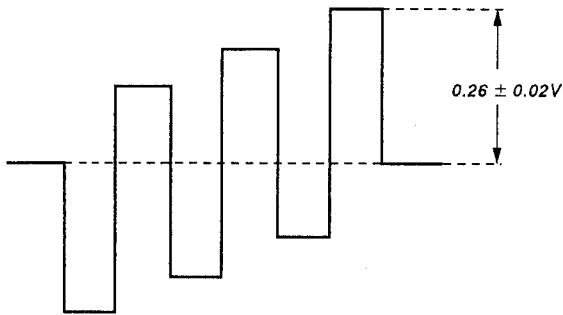

Fig. 6-12

7-7. Change the signal to PAL 75% color bars.

7-8. Connect the oscilloscope to CN305 Pin ③ and adjust RV312 so that the waveform is as in the figure below.

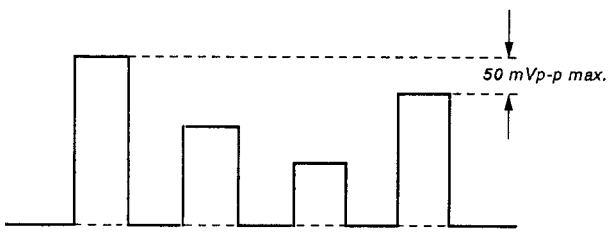

Fig. 6-13

8. Line crawling adjustment

8-1. Input 75% PAL color bars from Line 1.

8-2. Connect the oscilloscope to CN305 Pin ③ and check that the output difference per 1H for the waveform is under 5%.

8-3. If the difference is over 5%, measure between C416 and R373 and between C417 and R372, change the signal to a PAL SP CB signal and adjust T1 on CP301 to minimize the level difference per 1H of the anti-PAL signal.

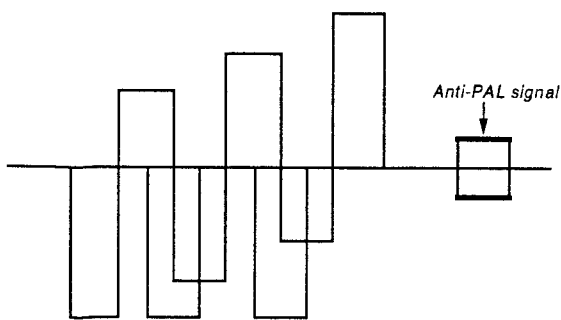

Fig. 6-14

8-4. Repeat the adjustment from 7-1.

9. SECAM bell filter adjustment

9-1. Input SECAM color bars to Line 1.

9-2. Connect the oscilloscope to IC303 Pin ⑳ and adjust T301 so that the waveform is as in the figure below.

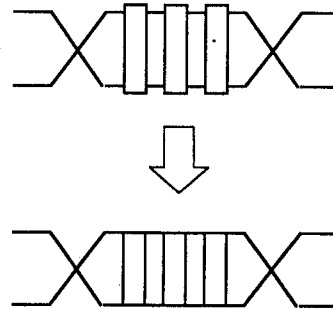

Fig. 6-15

9-3. Input SECAM color bars to Line 1 (100% white).

9-4. Connect the oscilloscope to the emitter of Q359 and adjust with RV313 so that the waveform is as in the figure below.

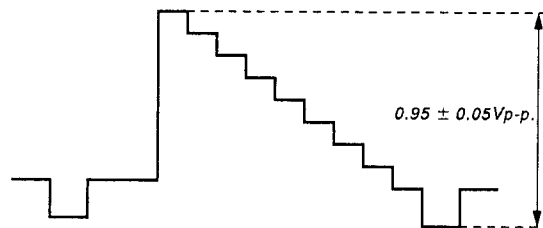

Fig. 6-16

9-5. Connect the oscilloscope between C417 and R372 and adjust LV301 so that the B-Y waveform no-color component level is a straight line.

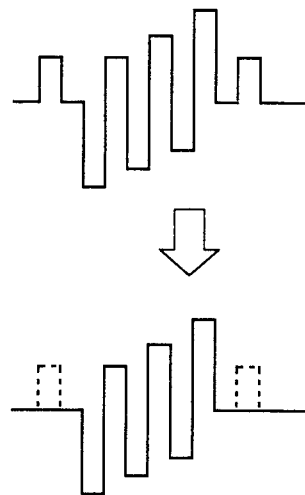

Fig. 6-17

9-6. Connect the oscilloscope between C416 and R373 and adjust LV301 so that the R-Y waveform no-color component level is a straight line.

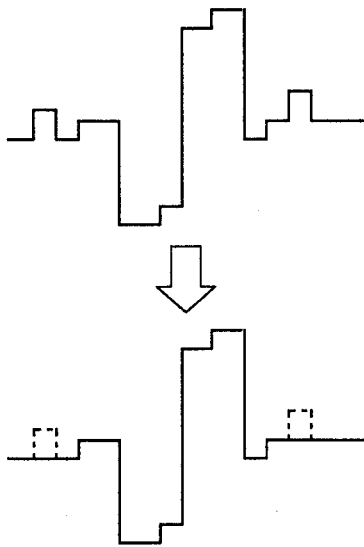

Fig. 6-18

9-7. Input SECAM color bars to Line 1 (75% chroma).

9-8. Connect the oscilloscope between C417 and R372 and adjust RV301 so that the B-Y waveform level is as in the figure below.

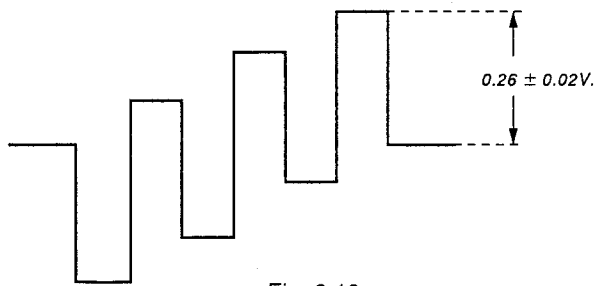

Fig. 6-19

9-9. Connect the oscilloscope between C416 and R373 and adjust RV302 so that the R-Y waveform level is as in the figure below.

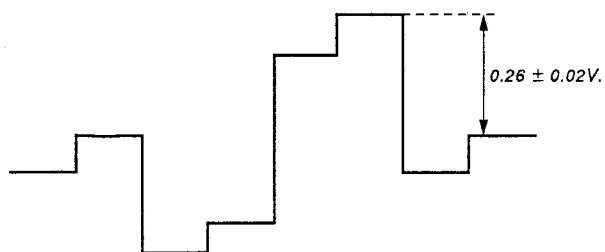

Fig. 6-20

9-10. Connect the oscilloscope to CN305 Pin ③ ¶ and adjust RV301 so that the heads of the B-Out waveforms line up.

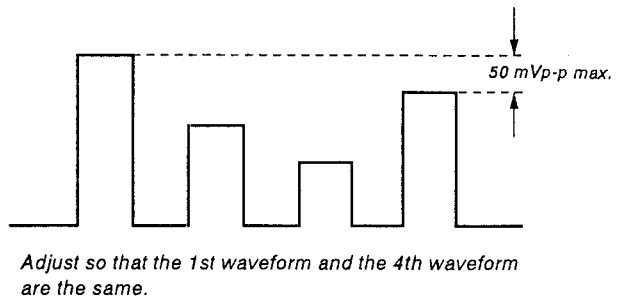
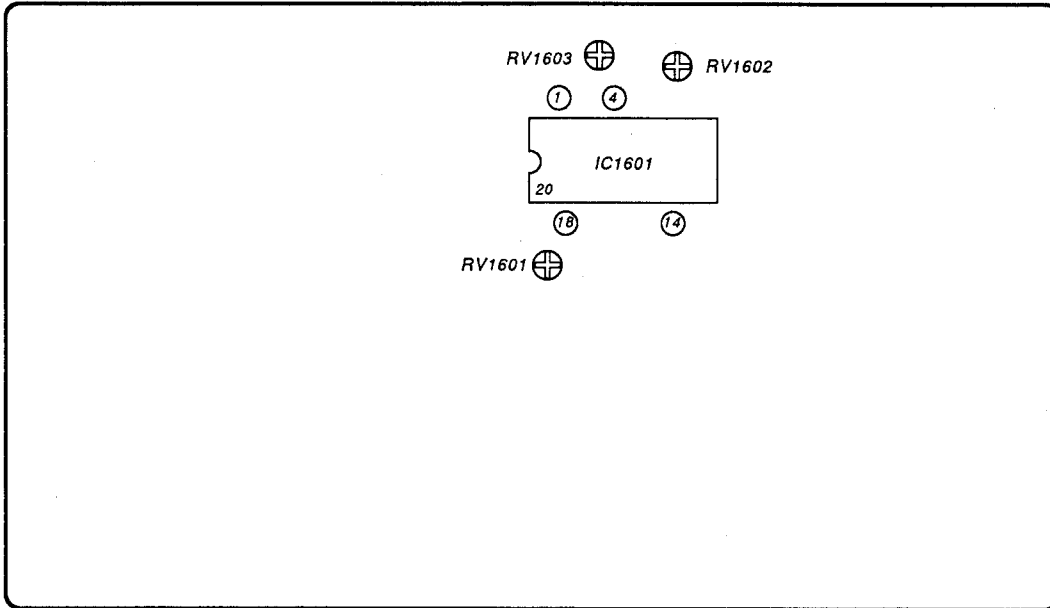

Fig. 6-21

6-2. A BOARD ADJUSTMENT

A BOARD — CONDUCTOR SIDE —



1. Hfo adjustment

- 1-1. Input NTSC color bars.
- 1-2. Short IC1601 Pin ① and Pin ⑭.
- 1-3. Connect a frequency counter to IC1601 Pin 4.
- 1-4. Adjust RV1602 so that the frequency is 15734 ± 50 Hz.
- 1-5. Input PAL color bars.
- 1-6. Adjust RV1603 so that the frequency is 15624 ± 50 Hz.
- 1-7. Remove the jumper from IC1601.

2. V Oscillator adjustment

- 2-1. Connect the oscilloscope to IC1601 Pin ⑬ and adjust RV1601 so that the waveform is as shown in the figure below.

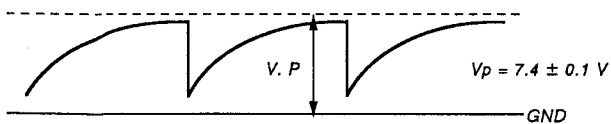
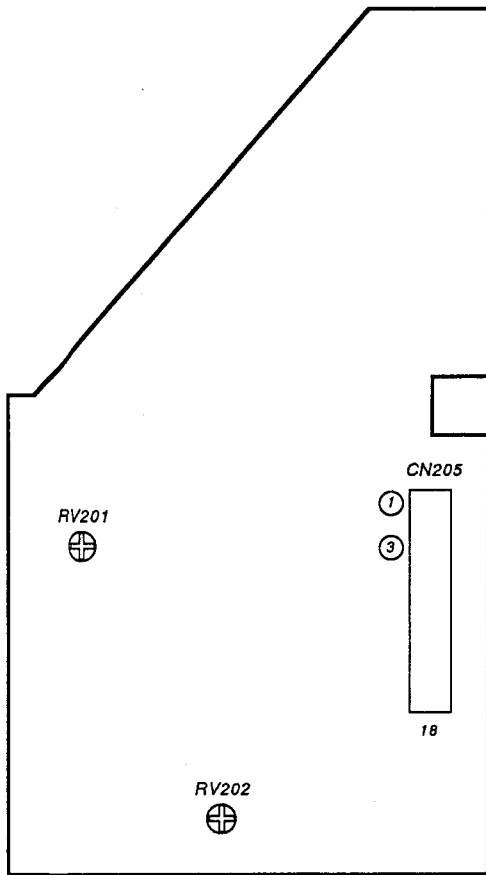

Fig. 6-22

6-3. UT BOARD ADJUSTMENT

UT BOARD – CONDUCTOR SIDE –



1. Y signal

- 1-1. Input a 75% white signal, 75% full field signal from SG1410.
- 1-2. Connect the oscilloscope to CN205 Pin ③ and adjust RV201 so that the Y level is as in the figure below.

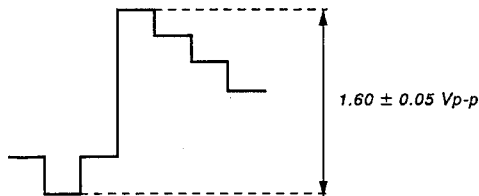

Fig. 6-23

- 1-3. Input a 14.31818MHz clock synchronized with the composite video signal to CN203 Pin ①.
- 1-4. Connect the oscilloscope to CN205 Pin ① and adjust RV202 so that the burst level is as shown in the diagram.

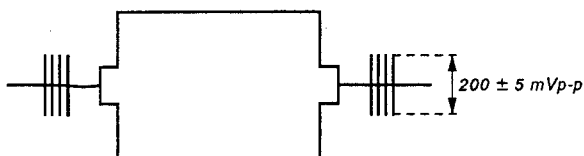
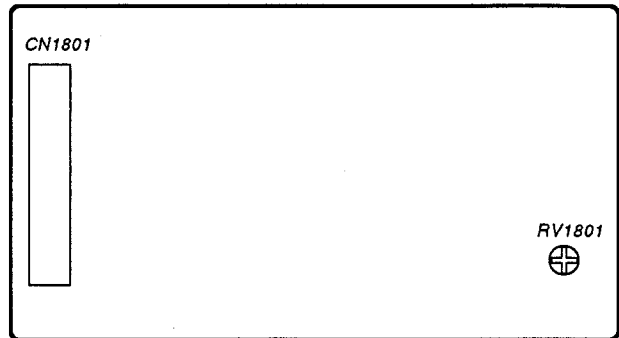

Fig. 6-24

6-4. VC BOARD ADJUSTMENT

VC BOARD – CONDUCTOR SIDE –



1. Use the circuit in the figure below

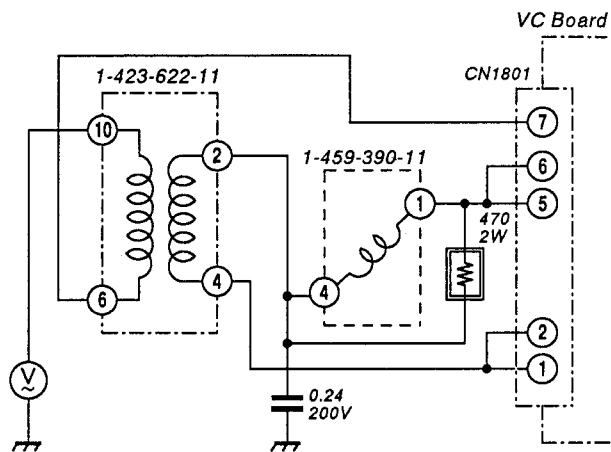

Fig. 6-25

2. Adjustment with RV1801 so that the reading of the voltmeter becomes maximum.

(Notes)

Regarding the white Balance Adjustment

Data memory for white balance adjustment is not available for all color temperatures of all signals.

Each data memory is assigned as shown in the table below. However, as variables are possible (adjustment of each item) for signals and color temperatures that have not been actually assigned, it is necessary to exercise care.

Example 1 :

At a setting of an input signal component and color temperature of 9300, a data variable of 01 : BRIGHT is possible, but as only one memory each is available for each color temperature, the BRIGHT data of the composite RGB may also change in the same manner when using this setting. (It is the same for the CONTRAST too.)

Example 2 :

Due to variations in the characteristics of the R CUT OFF, these characteristics have to be adjusted only in cases in which the white balance cannot be adjusted, but normally they are not adjusted. As there is only one data memory each for all conditions, the black level of the red color for all signals and color temperatures (the white balance of the black side) change when changing this data.

		1	2	3	4	5	6	7	8
		BRIGHT	G CUTOFF	B CUTOFF	G DRIVE	B DRIVE	CONTR.	R CUTOFF	RESET
COMPOS.	9,300	O	O	O	O	O	O	X	
	6,500	O	O	O	O	O	O	●	●
COMPONENT	9,300	X	O	O	X	X	X	X	
	6,500	X	O	O	X	X	X	X	
	3,200	X	O	O	X	X	X	X	
RGB	9,300	X	O	O	X	X	X	X	
	6,500	X	O	O	X	X	X	X	
	3,200	X	O	O	X	X	X	X	

O : Memory is available for each color temperature of the composite signals.

O : Memory is available for each color temperature for each signal.

● : Only one memory is available for all color temperatures of all signals

X : No memory is available. Data variation is possible, but basically no adjustment is made under this condition.

(Please refer to Example 1 and Example 2 in the preceding text.)

SECTION 7
DIAGRAMS

7-1. BLOCK DIAGRAMS (1)

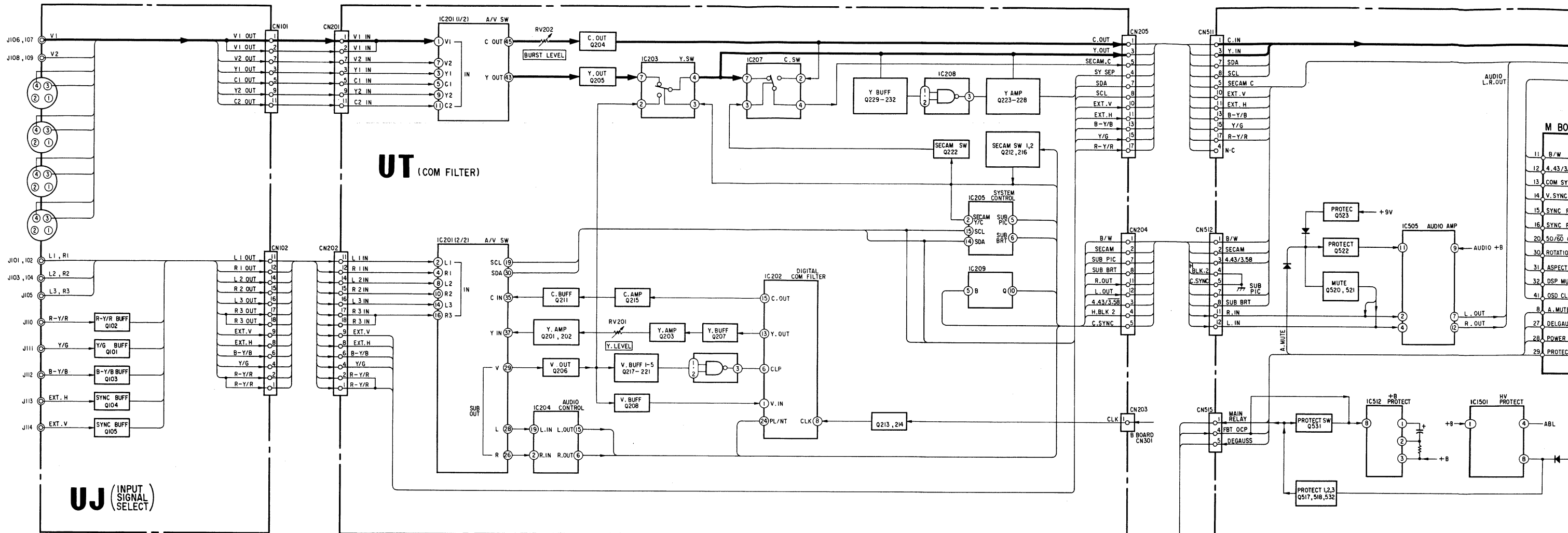

UJ (INPUT SIGNAL SELECT)

UT (COM FILTER)

G (AC IN POWER) AEP/Australian Model

G (AC IN POWER) US/Canadian Model

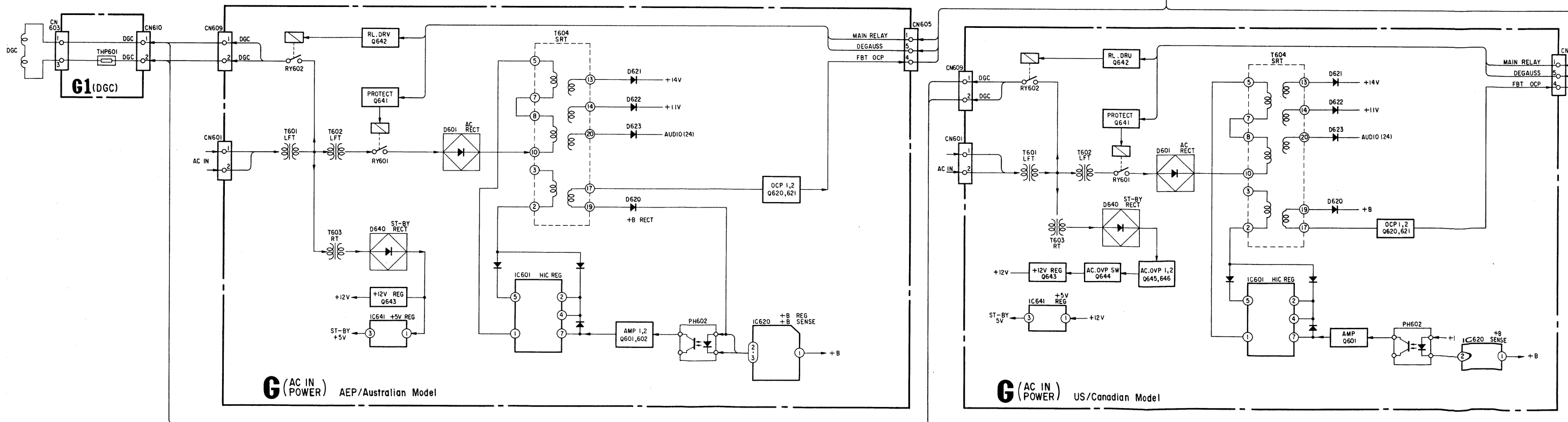

G1 (DGC)

G (AC IN POWER) AEP/Australian Model

G (AC IN POWER) US/Canadian Model

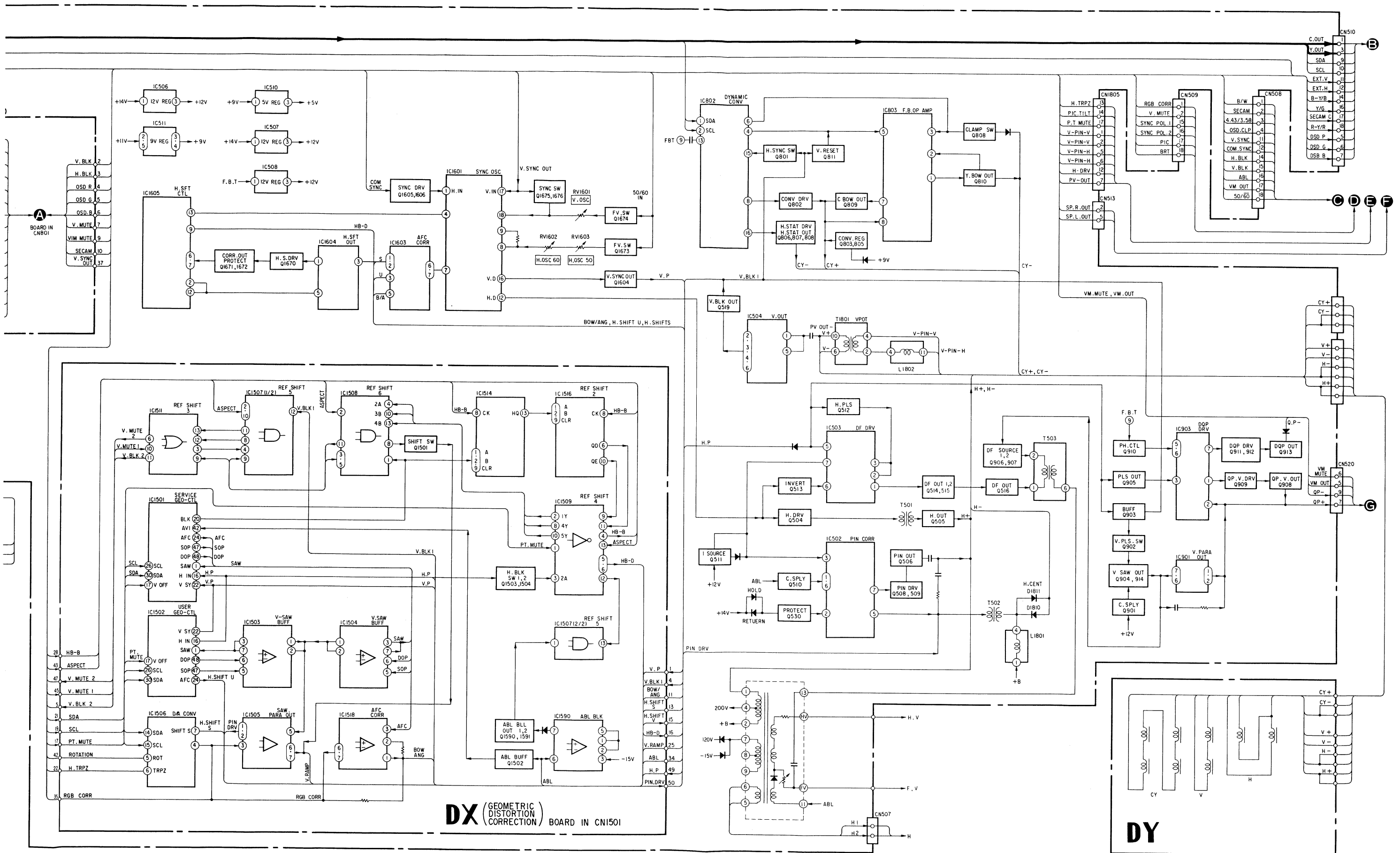

BLOCK DIAGRAMS (2)

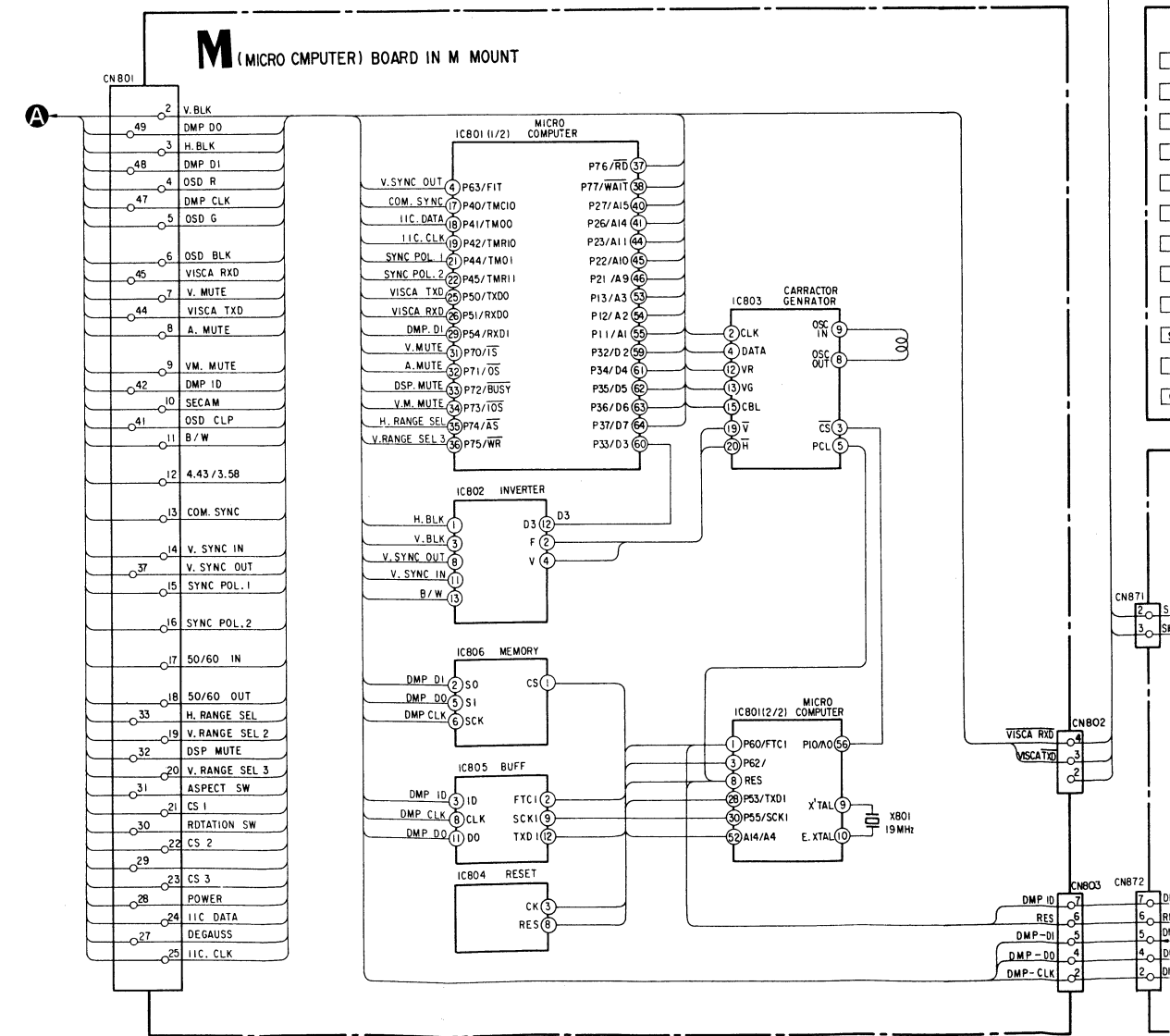
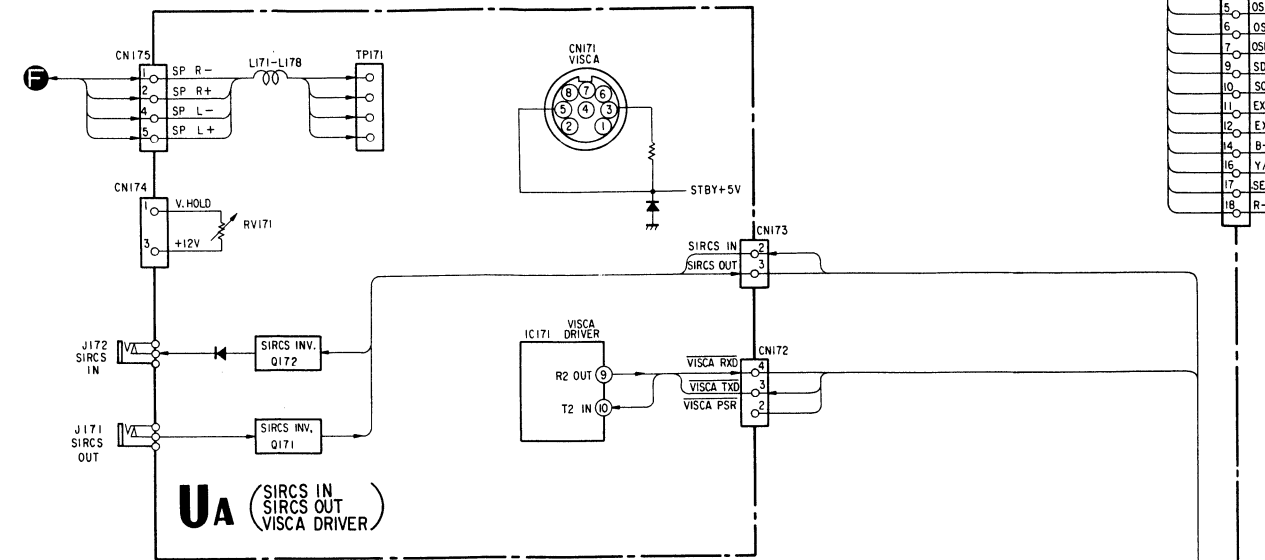

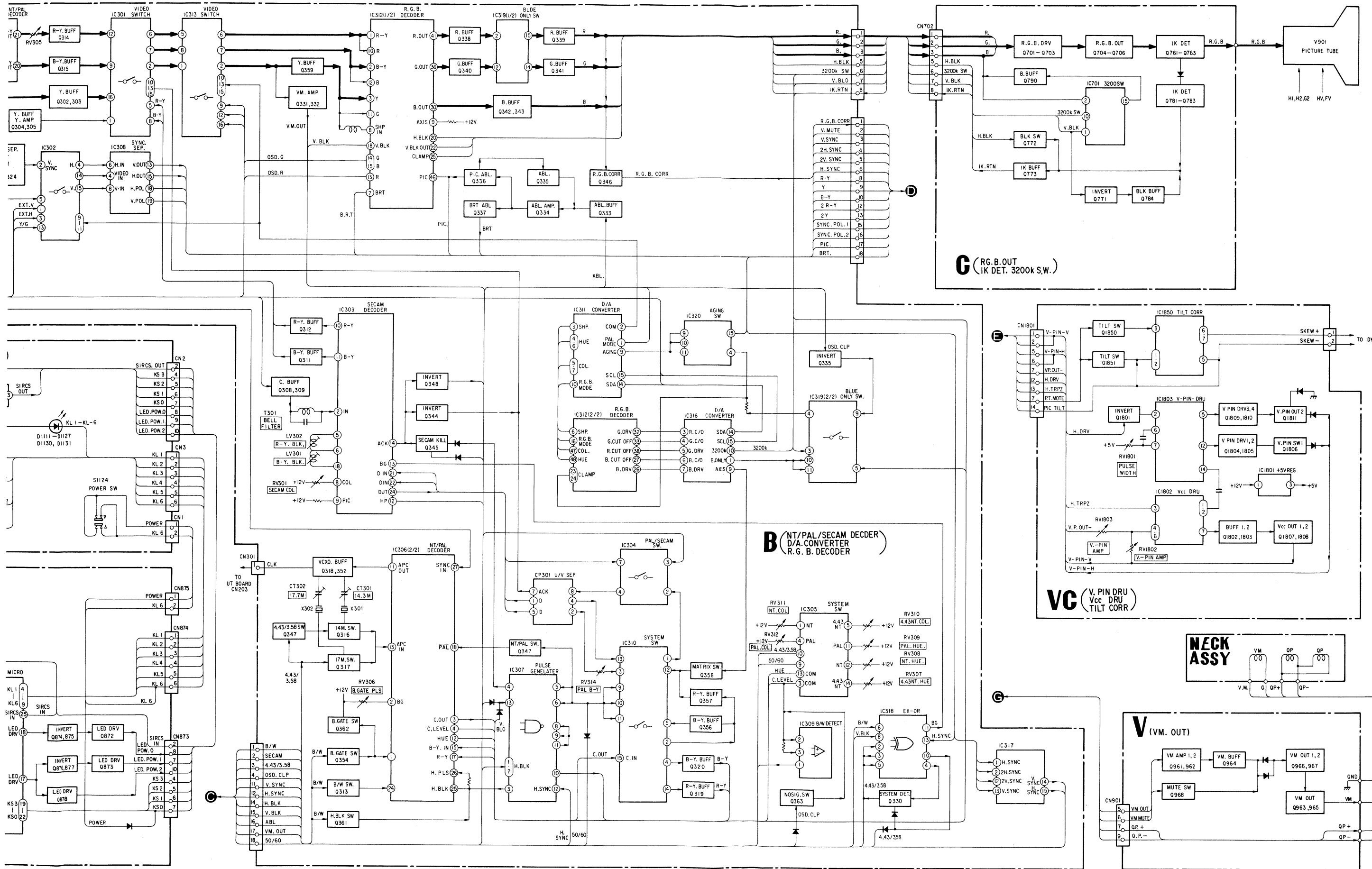

7-2. FRAME SCHEMATIC DIAGRAM

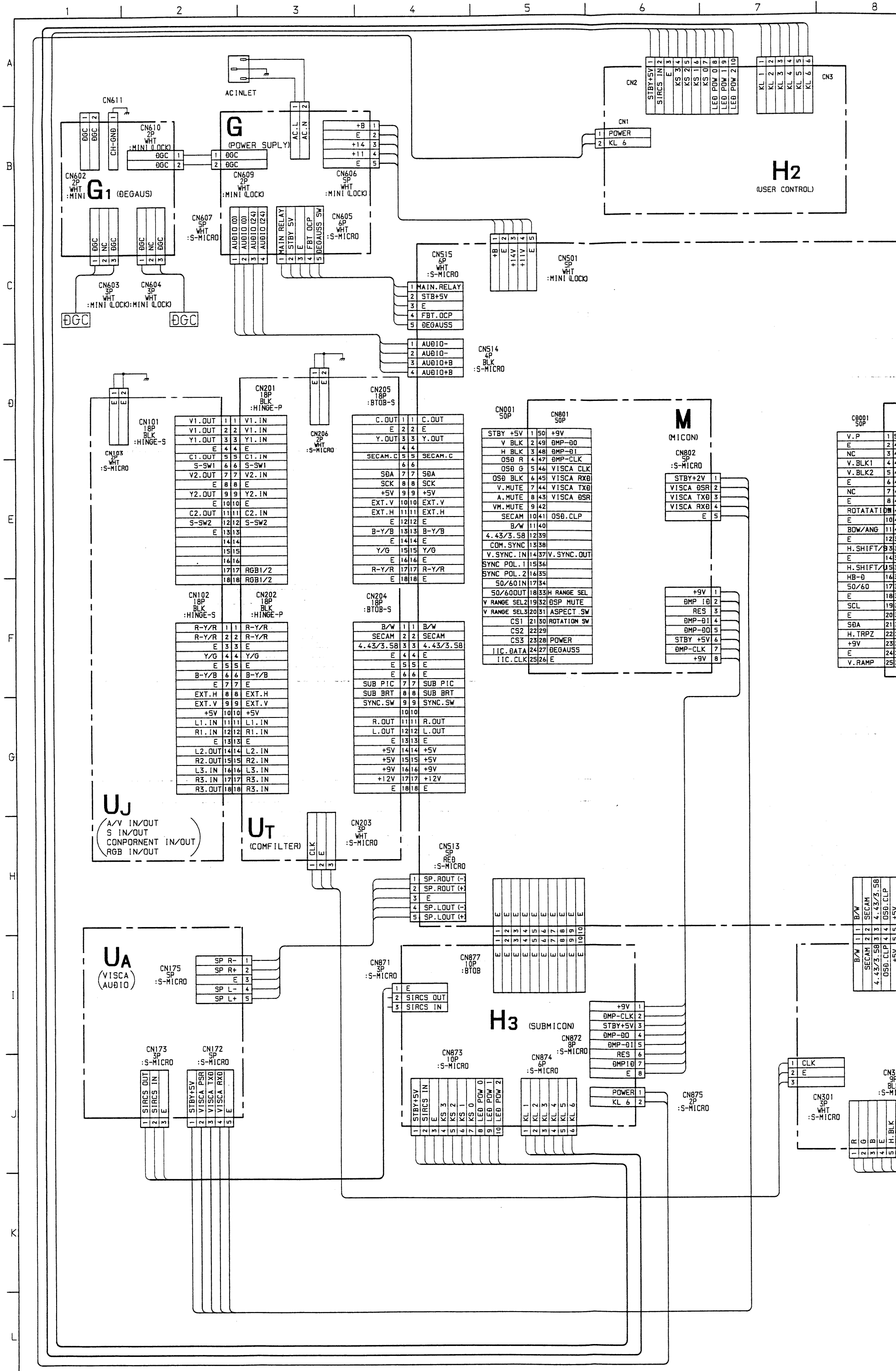

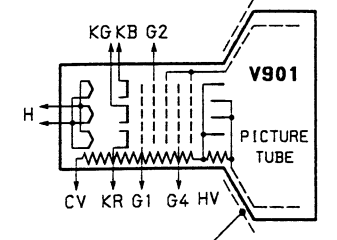
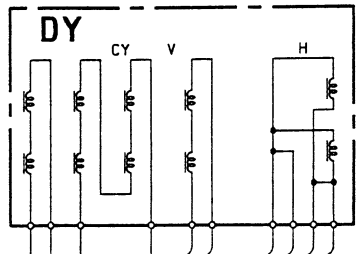

CB001 50P		CN1501 50P	
V.P	1	50	PIN. DRV
E	2	49	H.P
NC	3	48	E
V. BLK1	4	47	V. MUTE2
V. BLK2	5	46	E
E	6	45	V. MUTE1
NC	7	44	E
E	8	43	ASPECT
ROTATI	9	42	ROTATION
E	10	41	E
BOW/ANG	11	40	BOW/ANG
E	12	39	E
H. SHIFT/	13	38	H. SHIFT/S
E	14	37	E
H. SHIFT/	15	36	H. SHIFT/U
HB-0	16	35	RGB. CORR
50/60	17	34	ABL
E	18	33	E
SCL	19	32	E
E	20	31	E
S0A	21	30	E
H. TRPZ	22	29	E
+9V	23	28	HB-B
E	24	27	0SP. MUTE
V. RAMP	25	26	+5V

DX
(SYSTEM CONT)

CN1805 18P :BTOB		Vc (V-PIN Q P)	
V-PIN-V	1	1	V-PIN-V
V-PIN-V	2	2	V-PIN-V
E	3	3	E
E	4	4	E
V-PIN-H	5	5	V-PIN-H
V-PIN-H	6	6	V-PIN-H
VP-OUT-	7	7	VP-OUT-
FBT-15V	8	8	FBT-15V
FBT-15V	9	9	FBT-15V
FBT 12V	10	10	FBT 12V
FBT 12V	11	11	FBT 12V
H. DRV	12	12	H. DRV
H. TRPZ	13	13	H. TRPZ
PIC. TILT	14	14	PIC. TILT
E	15	15	E
E	16	16	E
P.T MUTE	17	17	P.T MUTE
E	18	18	E

1000V	1	1	1000V
200V	2	2	200V
E	3	3	E
N.C	4	4	E
H1	5	5	H1
H2	6	6	H2

CN704 2P :MINI		C (RGB OUT)	
R	1		
G	2		
B	3		
E	4		
H. BLK	5		
V. BLK	6		
I.K. RTN	7		
+12V	8		

CN702 8P :S-MICRO	
1	
2	
3	
4	
5	
6	
7	
8	

CN507 5P :MINI LOCK		BY-2 3P :MINI	
1		CY+	1
2			2
3		CY-	3

(SYNC OSC. DYNAMIC CONV.
H. SFT CONTROL.
V. PARA OUT. 0QP DRIVE.
H/V OUT. HV PROTECT.
AUDIO AMP. 0F DRIVE.) **A**

CN803 8P :S-MICRO		CN901 9P :S-MICRO	
+B	1	1	+B
+B	2	2	+B
E	3	3	E
12V	4	4	12V
VM OUT	5	5	VM OUT
VM MUTE	6	6	VM MUTE
G.P.+	7	7	G.P.+
NC	8	8	NC
G.P.-	9	9	G.P.-

V
(VM AMP)

CN508 18P :BTOB		CN303 18P :BTOB	
B/W	1	B/W	1
SECAM	2	SECAM	2
4.43/3.58	3	4.43/3.58	3
OSD. CLP	4	OSD. CLP	4
+5V	5	+5V	5
+5V	6	+5V	6
+12V	7	+12V	7
12V	8	12V	8
+9V	9	+9V	9
E	10	E	10
V. SYNC	11	V. SYNC	11
H. SYNC	12	H. SYNC	12
E	13	E	13
H. BLK	14	H. BLK	14
V. BLK	15	V. BLK	15
ABL	16	ABL	16
VM. OUT	17	VM. OUT	17
50/60	18	50/60	18

CN509 18P :BTOB		CN304 18P :BTOB	
RGB. CORR	1	RGB. CORR	1
V MUTE	2	V MUTE	2
V SYNC	3	V SYNC	3
2H SYNC	4	2H SYNC	4
2V SYNC	5	2V SYNC	5
H SYNC	6	H SYNC	6
E	7	E	7
R-Y	8	R-Y	8
Y	9	Y	9
B-Y	10	B-Y	10
E	11	E	11
2 R-Y	12	2 R-Y	12
2Y	13	2Y	13
2 B-Y	14	2 B-Y	14
SYNC. POL. 1	15	SYNC. POL. 1	15
SYNC. POL. 2	16	SYNC. POL. 2	16
PIC	17	PIC	17
BRT	18	BRT	18

CN510 18P :BTOB		CN302 18P :BTOB	
C. IN	1	C. IN	1
E	2	E	2
Y. IN	3	Y. IN	3
E	4	E	4
OSD. R	5	OSD. R	5
OSD. G	6	OSD. G	6
OSD. BLK	7	OSD. BLK	7
E	8	E	8
S0A	9	S0A	9
SCK	10	SCK	10
EXT. V	11	EXT. V	11
EXT. H	12	EXT. H	12
E	13	E	13
B-Y/B	14	B-Y/B	14
E	15	E	15
Y/G	16	Y/G	16
SECAM. C	17	SECAM. C	17
R-Y/R	18	R-Y/R	18

(SYNC SEP. SYNC SW.
VIDEO SW. PULSE GENE.
SECAM DECOD
NT/PAL DECOD
SYSTEM SW) **B**

CN301 3P :S-MICRO		CN305 9P :S-MICRO	
R	1	R	1
G	2	G	2
B	3	B	3
E	4	E	4
H. BLK	5	H. BLK	5
3200K SW	6	3200K SW	6
V. BLD	7	V. BLD	7
I.K. RTN	8	I.K. RTN	8
+12V	9	+12V	9

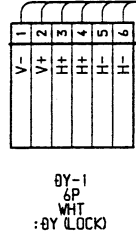
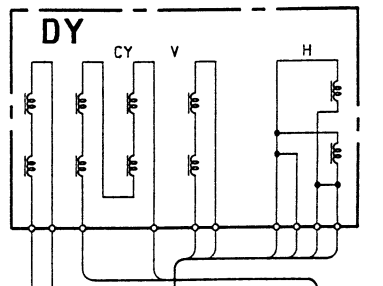
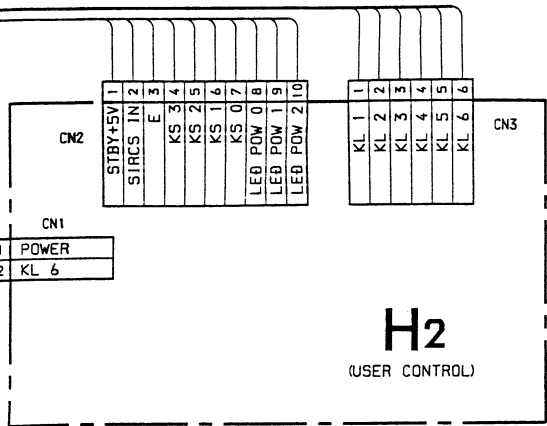

1000V	1	1	1000V
200V	2	2	200V
E	3	3	E
N.C	4	4	
H1	5	5	H1
H2	6	6	H2



(RGB OUT)

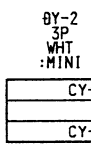

CY+	1
	2
CY-	3

M (MICON)

CN802 5P :S-MICRO

STBY+2V	1
VISCA ØSR	2
VISCA TXØ	3
VISCA RXØ	4
E	5

+9V	1
ØMP 1Ø	2
RES	3
ØMP-Ø1	4
ØMP-Ø0	5
STBY +5V	6
ØMP-CLK	7
+9V	8

C8001 50P

V.P	1	50	PIN.ØRV
E	2	49	H.P
NC	3	48	E
V.BLK1	4	47	V.MUTE2
V.BLK2	5	46	E
E	6	45	V.MUTE1
NC	7	44	E
E	8	43	ASPECT
ROTATATI	9	42	ROTATION
E	10	41	E
BØW/ANG	11	40	BØW/ANG
E	12	39	E
H.SHIFT/	13	38	H.SHIFT/S
E	14	37	E
H.SHIFT/	15	36	H.SHIFT/U
HB-Ø	16	35	RGB.CORR
50/60	17	34	ABL
E	18	33	E
SCL	19	32	E
E	20	31	E
SØA	21	30	E
H.TRPZ	22	29	E
+9V	23	28	HB-B
E	24	27	ØSP.MUTE
V.RAMP	25	26	+5V

CN1501 50P

V-PIN-V	1	1	V-PIN-V
V-PIN-V	2	2	V-PIN-V
E	3	3	E
E	4	4	E
V-PIN-H	5	5	V-PIN-H
V-PIN-H	6	6	V-PIN-H
VP-OUT-	7	7	VP-OUT-
FBT-15V	8	8	FBT-15V
FBT-15V	9	9	FBT-15V
FBT 12V	10	10	FBT 12V
FBT 12V	11	11	FBT 12V
H.ØRV	12	12	H.ØRV
H.TRPZ	13	13	H.TRPZ
PIC.TILT	14	14	PIC.TILT
	15	15	
	16	16	
P.T MUTE	17	17	P.T MUTE
	18	18	

DX (SYSTEM CONT)

CN1805 18P :BTØB

V-PIN-V	1	1	V-PIN-V
V-PIN-V	2	2	V-PIN-V
E	3	3	E
E	4	4	E
V-PIN-H	5	5	V-PIN-H
V-PIN-H	6	6	V-PIN-H
VP-OUT-	7	7	VP-OUT-
FBT-15V	8	8	FBT-15V
FBT-15V	9	9	FBT-15V
FBT 12V	10	10	FBT 12V
FBT 12V	11	11	FBT 12V
H.ØRV	12	12	H.ØRV
H.TRPZ	13	13	H.TRPZ
PIC.TILT	14	14	PIC.TILT
	15	15	
	16	16	
P.T MUTE	17	17	P.T MUTE
	18	18	

Vc (V-PIN Q P)

CN1850 2P WHT :S-MICRO

SKEM+	1
SKEM-	2

CN1801 18P :BTØB

CN803 9P WHT :S-MICRO

+B	1
+B	2
E	3
12V	4
VM OUT	5
VM MUTE	6
Q.P+	7
NC	8
Q.P-	9

CN901 9P WHT :S-MICRO

+B	1
+B	2
E	3
12V	4
VM OUT	5
VM MUTE	6
Q.P+	7
NC	8
Q.P-	9

(SYNC OSC. ØYNAMIC CONV. H.SFT CONTROL V.PARA OUT. ØQP ØRIVE. H/V OUT. HV PROTECT. AUDIO AMP. ØF ØRIVE.)

A

CN508 18P :BTØB

B/W	1	1	B/W
SECAM	2	2	SECAM
4.43/3.58	3	3	4.43/3.58
ØSD.CLIP	4	4	ØSD.CLIP
+5V	5	5	+5V
+5V	6	6	+5V
+12V	7	7	+12V
+9V	8	8	+9V
+9V	9	9	+9V
E	10	10	E
V.SYNC	11	11	V.SYNC
H.SYNC	12	12	H.SYNC
E	13	13	E
H.BLK	14	14	H.BLK
V.BLK	15	15	V.BLK
ABL	16	16	ABL
VM.OUT	17	17	VM.OUT
50/60	18	18	50/60

CN509 18P :BTØB

RGB.CORR	1	1	RGB.CORR
V MUTE	2	2	V MUTE
V SYNC	3	3	V SYNC
2H SYNC	4	4	2H SYNC
2V SYNC	5	5	2V SYNC
H SYNC	6	6	H SYNC
E	7	7	E
R-Y	8	8	R-Y
Y	9	9	Y
B-Y	10	10	B-Y
E	11	11	E
2 R-Y	12	12	2 R-Y
2Y	13	13	2Y
2 B-Y	14	14	2 B-Y
SYNC.POL.1	15	15	SYNC.POL.1
SYNC.POL.2	16	16	SYNC.POL.2
PIC	17	17	PIC
BRT	18	18	BRT

CN510 18P :BTØB

C.IN	1	1	C.IN
E	2	2	E
Y.IN	3	3	Y.IN
E	4	4	E
ØSD.R	5	5	ØSD.R
ØSD.G	6	6	ØSD.G
ØSD.BLK	7	7	ØSD.BLK
E	8	8	E
SØA	9	9	SØA
SCK	10	10	SCK
EXT.V	11	11	EXT.V
EXT.H	12	12	EXT.H
E	13	13	E
B-Y/B	14	14	B-Y/B
E	15	15	E
Y/G	16	16	Y/G
SECAM.C	17	17	SECAM.C
R-Y/R	18	18	R-Y/R

CN303 18P :BTØB

B/W	1	1	B/W
SECAM	2	2	SECAM
4.43/3.58	3	3	4.43/3.58
ØSD.CLIP	4	4	ØSD.CLIP
+5V	5	5	+5V
+5V	6	6	+5V
+12V	7	7	+12V
+9V	8	8	+9V
+9V	9	9	+9V
E	10	10	E
V.SYNC	11	11	V.SYNC
H.SYNC	12	12	H.SYNC
E	13	13	E
H.BLK	14	14	H.BLK
V.BLK	15	15	V.BLK
ABL	16	16	ABL
VM.OUT	17	17	VM.OUT
50/60	18	18	50/60

CN304 18P :BTØB

RGB.CORR	1	1	RGB.CORR
V MUTE	2	2	V MUTE
V SYNC	3	3	V SYNC
2H SYNC	4	4	2H SYNC
2V SYNC	5	5	2V SYNC
H SYNC	6	6	H SYNC
E	7	7	E
R-Y	8	8	R-Y
Y	9	9	Y
B-Y	10	10	B-Y
E	11	11	E
2 R-Y	12	12	2 R-Y
2Y	13	13	2Y
2 B-Y	14	14	2 B-Y
SYNC.POL.1	15	15	SYNC.POL.1
SYNC.POL.2	16	16	SYNC.POL.2
PIC	17	17	PIC
BRT	18	18	BRT

CN302 18P :BTØB

C.IN	1	1	C.IN
E	2	2	E
Y.IN	3	3	Y.IN
E	4	4	E
ØSD.R	5	5	ØSD.R
ØSD.G	6	6	ØSD.G
ØSD.BLK	7	7	ØSD.BLK
E	8	8	E
SØA	9	9	SØA
SCK	10	10	SCK
EXT.V	11	11	EXT.V
EXT.H	12	12	EXT.H
E	13	13	E
B-Y/B	14	14	B-Y/B
E	15	15	E
Y/G	16	16	Y/G
SECAM.C	17	17	SECAM.C
R-Y/R	18	18	R-Y/R

CN301 5P WHT :S-MICRO

1	CLK
2	E
3	

CN305 9P BLK :S-MICRO

1	R
2	G
3	B
4	E
5	H.BLK
6	3200K SW
7	V.BLO
8	IK.RTN
9	+12V

(SYNC SEP. SYNC SW. VIDEO SW. PULSE GENE. SECAM DECOD NT/PAL DECOD SYSTEM SW)

B

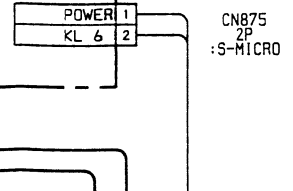
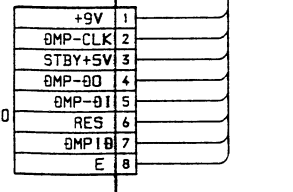

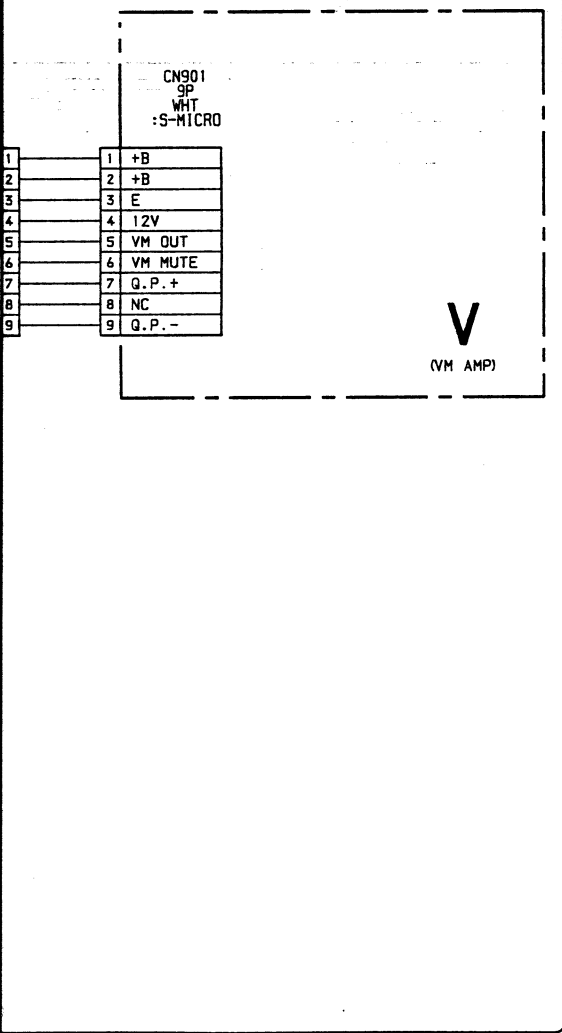
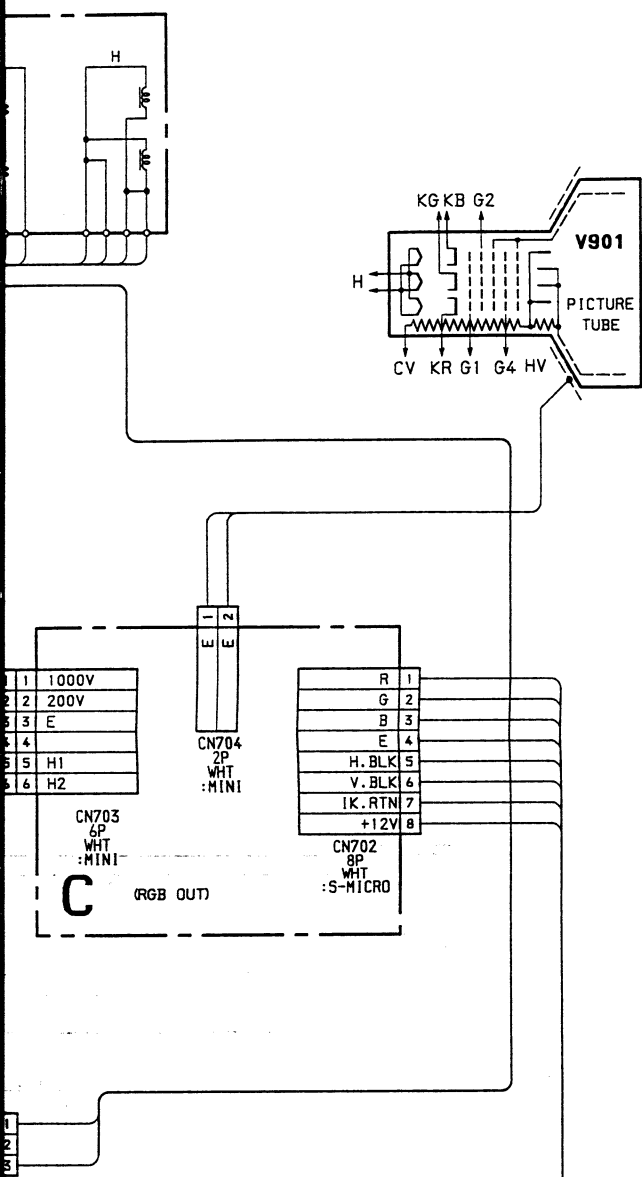

B-SS3218<U/C>-KESSENZU

7-3. CIRCUIT BOARDS LOCATION

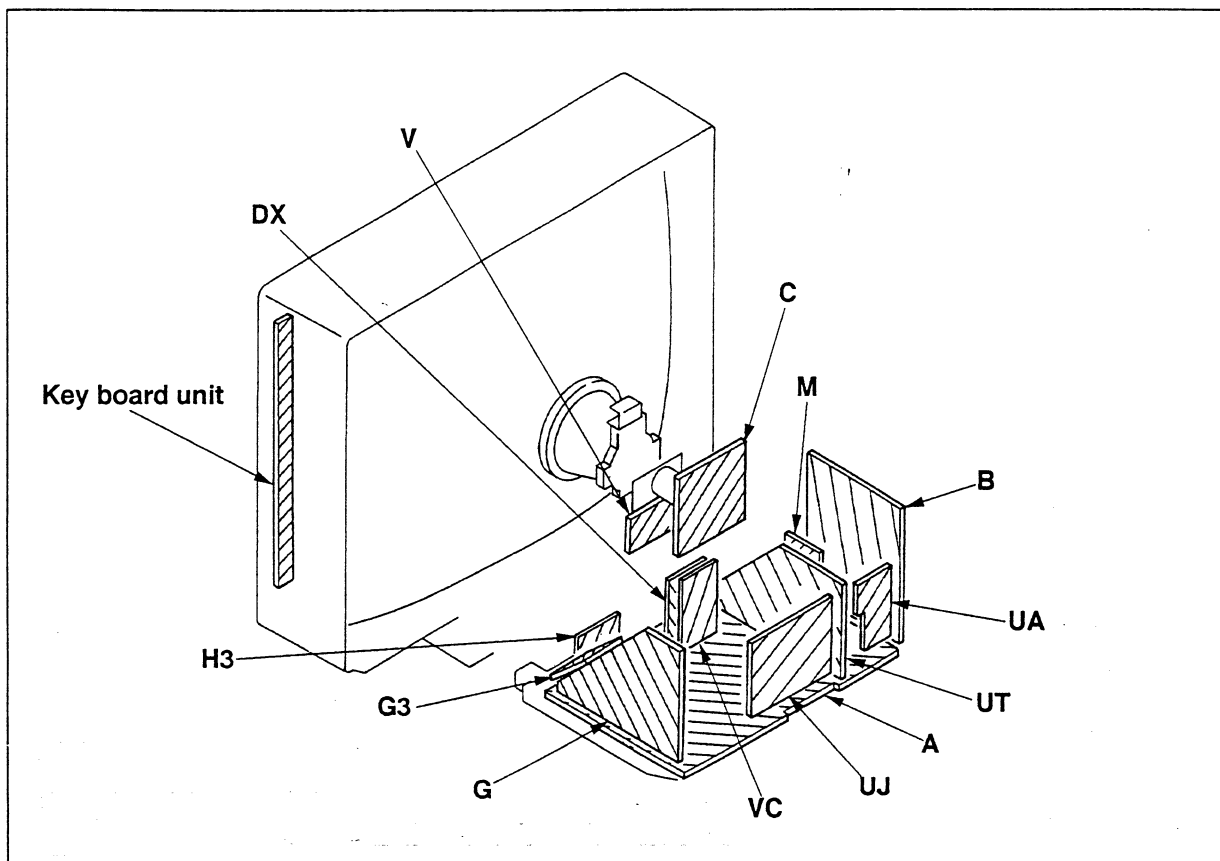

7-4. SCHEMATIC DIAGRAMS AND PRINTED WIRING BOARDS

Note:

- All capacitors are in μF unless otherwise noted. pF : μF 50WV or less are not indicated except for electrolytic and tantalums.
- All electrolytics are in 50V unless otherwise specified.
- All resistors are in ohms. $\text{K}\Omega = 1000\Omega$, $\text{M}\Omega = 1000\text{K}\Omega$
- Indication of resistance, which does not have one for rating electrical power, is as follows.

Pitch: 5 mm
Rating electrical power 1/4W

- Chips resistors are 1/10W.
- : nonflammable resistor.
- : internal component.
- : panel designation, and adjustment for repair.
- All variable and adjustable resistors have characteristic curve B, unless otherwise noted.
- : earth-ground.
- : earth-chassis.
- : earth-chassis.
- The components identified by in this manual have been carefully factory-selected for each set in order to satisfy regulations regarding X-ray radiation. Should replacement be required, replace only with the value originally used.
- When replacing components identified by mark the necessary adjustments indicated. If results do not meet the specified value, change the component identified by and repeat the adjustment until the specified value is achieved. (Refer to R581 and R583 on Page 28, 29 in the Service Manual.)
- When replacing the part in below table be sure to perform the related adjustment.

Part replaced ()	Adjustment ()
C574, D515, IC501, Q517, Q518, R578, R580, R581, R582, R583, R584, R585, T504..... A BOARD IC620 G BOARD	R581 (HOLD-DOWN)
C574, D515, IC501, Q517, Q518, R578, R580, R581, R582, R583, R584, R585, T504..... A BOARD IC620 G BOARD	R583 (HOLD-DOWN)

- Readings are taken with a color-bar signal input.
- Readings are taken with a 10 M Ω digital multimeter.
- Voltage are dc with respect to ground unless otherwise noted.
- Voltage variations may be noted due to normal production tolerance.
- All voltages are in V.
- : B+ bus.
- : B- bus.
- : signal path.

Reference information

RESISTOR	: RN	METAL FILM
	: RC	SOLID
	: FPRD	NONFLAMMABLE CARBON
	: FUSE	NONFLAMMABLE FUSIBLE
	: RW	NONFLAMMABLE WIREWOUND
	: RS	NONFLAMMABLE METALOXIDE
	: RB	NONFLAMMABLE CEMENT
	: *	ADJUSTMENT RESISTOR
COIL	: LF-8L	MICRO INDUCTOR
CAPACITOR	: TA	TANTALUM
	: PS	STYROL
	: PP	POLYPROPYLENE
	: PT	MYLAR
	: MPS	METALIZED POLYESTER
	: MPP	METALIZED POLYPROPYLENE
	: ALB	BIPOLAR
	: ALT	HIGH TEMPERATURE
	: ALR	HIGH RIPPLE

Note: The components identified by shading and mark are critical for safety. Replace only with part number specified.

Note: Les composants identifiés par une trame et par une marque sont d'une importance critique pour la sécurité. Ne les remplacer que par des pièces de numéro spécifié.

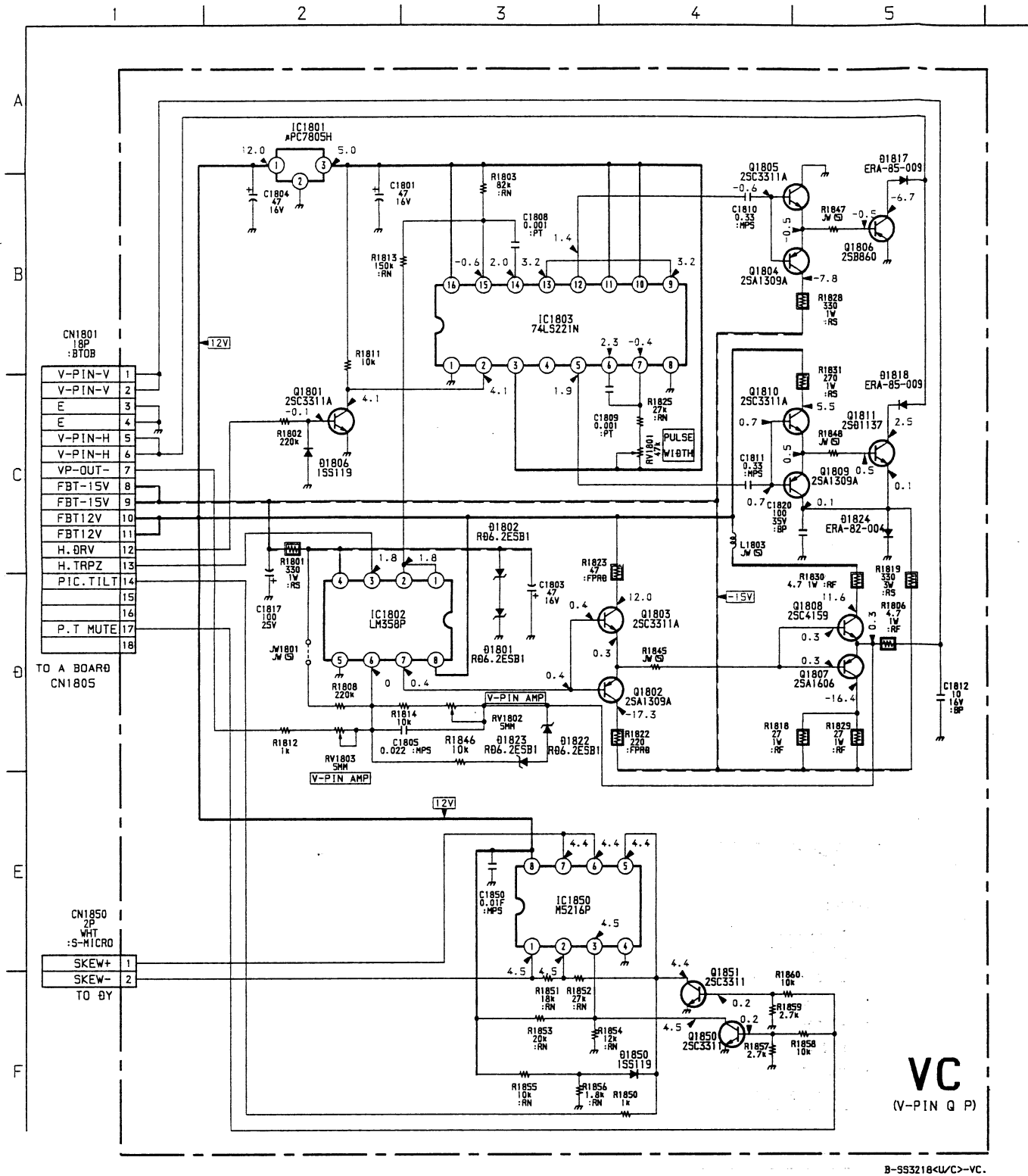

VC
(V-PIN Q P)

B-553218<U/C>-VC.

VC BOARD

D1801	CLIP 2
D1802	CLIP 1
D1806	PROTECT
D1817	V PIN SW 1
D1818	V PIN SW 2
D1822	PIN GAMMA 1
D1823	PIN GAMMA 2
D1824	C SOURCE
D1850	MUTE SW
IC1801	5V REG
IC1802	VCC DRC
IC1803	V PIN DRV
IC1850	TILT CORR
Q1801	INVERT
Q1802	BUFF 2
Q1803	BUFF 1
Q1804	V PIN DRV 2
Q1805	V PIN DRV 1
Q1806	V PIN OUT 1
Q1807	VCC OUT 2
Q1808	VCC OUT 1
Q1809	V PIN DRV 4
Q1810	V PIN DRV 3
Q1811	V PIN OUT 2
Q1850	TILT SW
Q1851	TILT SW

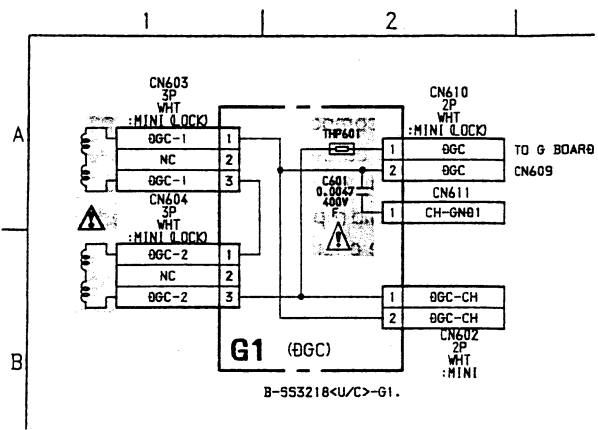

G1 (G1C)

B-553218<U/C>-G1.

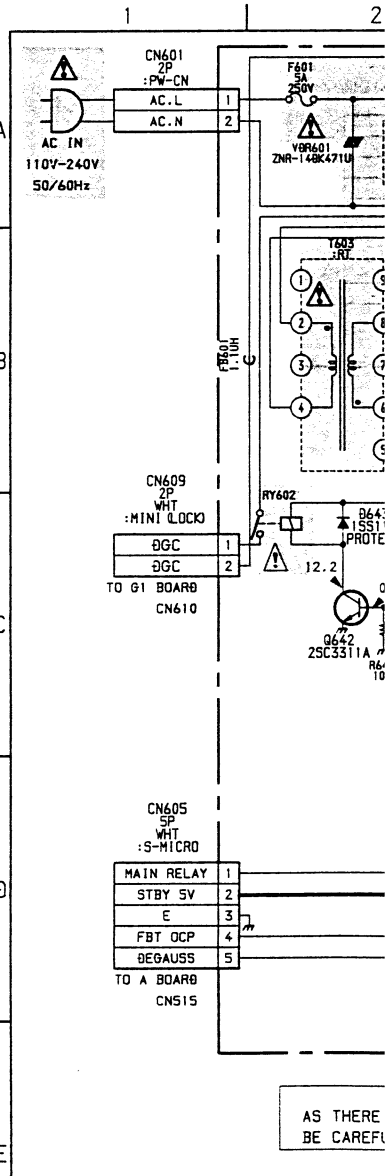

G
(POWER SUPPLY)

This set is equipped with a blade of the plug of the ac power cord, be as shown in the...

Schematic diagrams

- G G1 H2 boards →
H3 VC

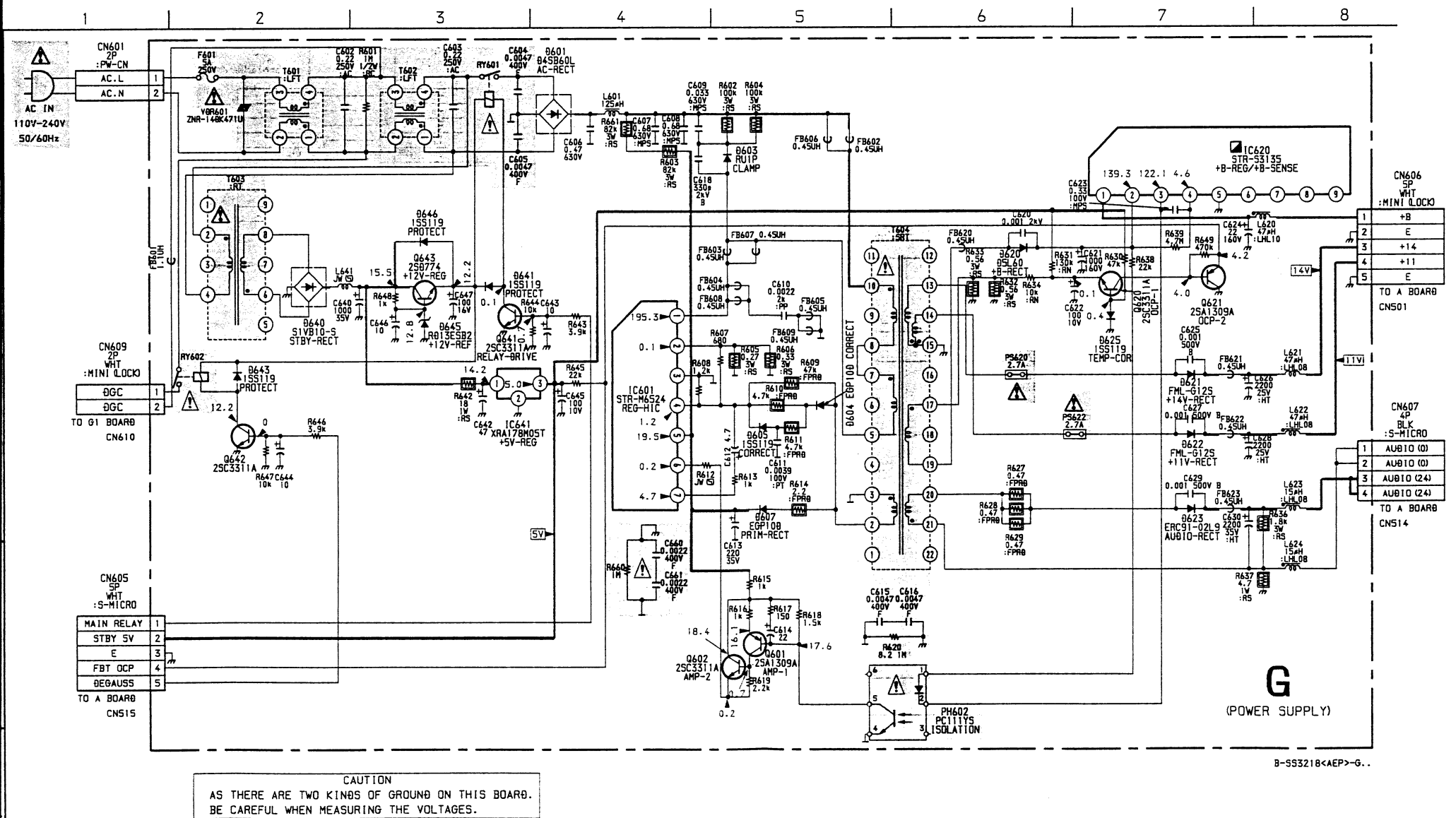
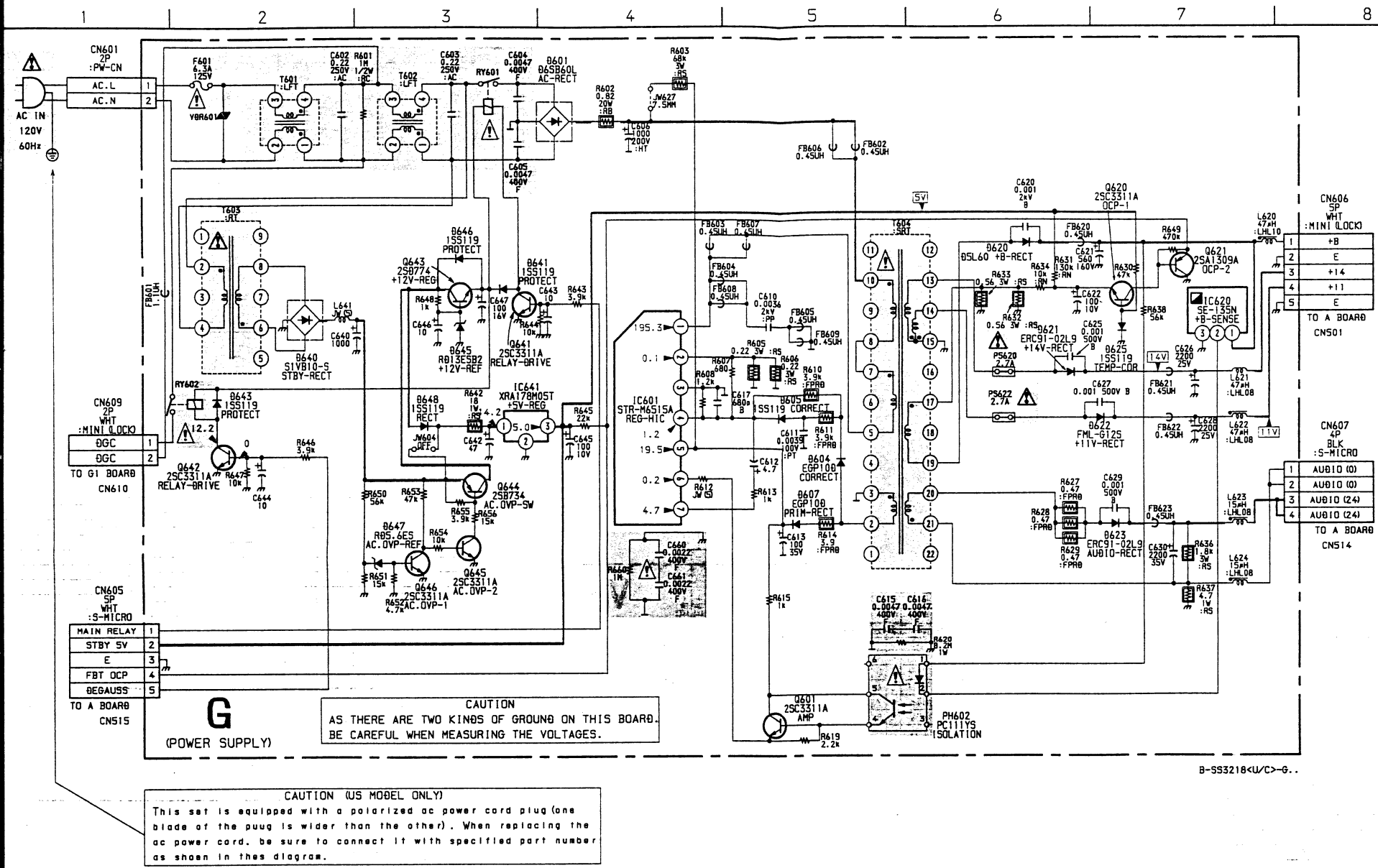

(US, Canadian Model)

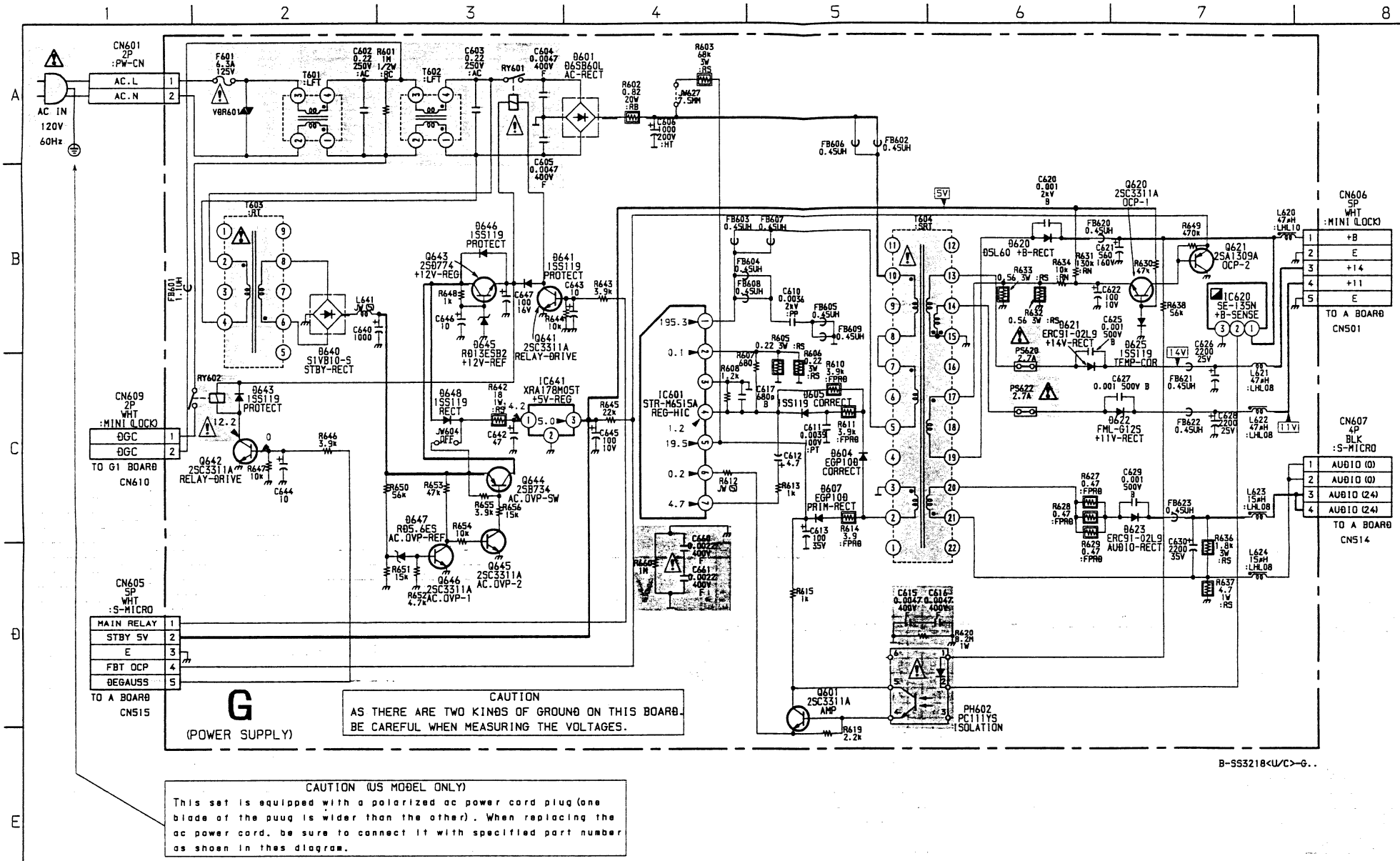

(AEP, AUS Model)

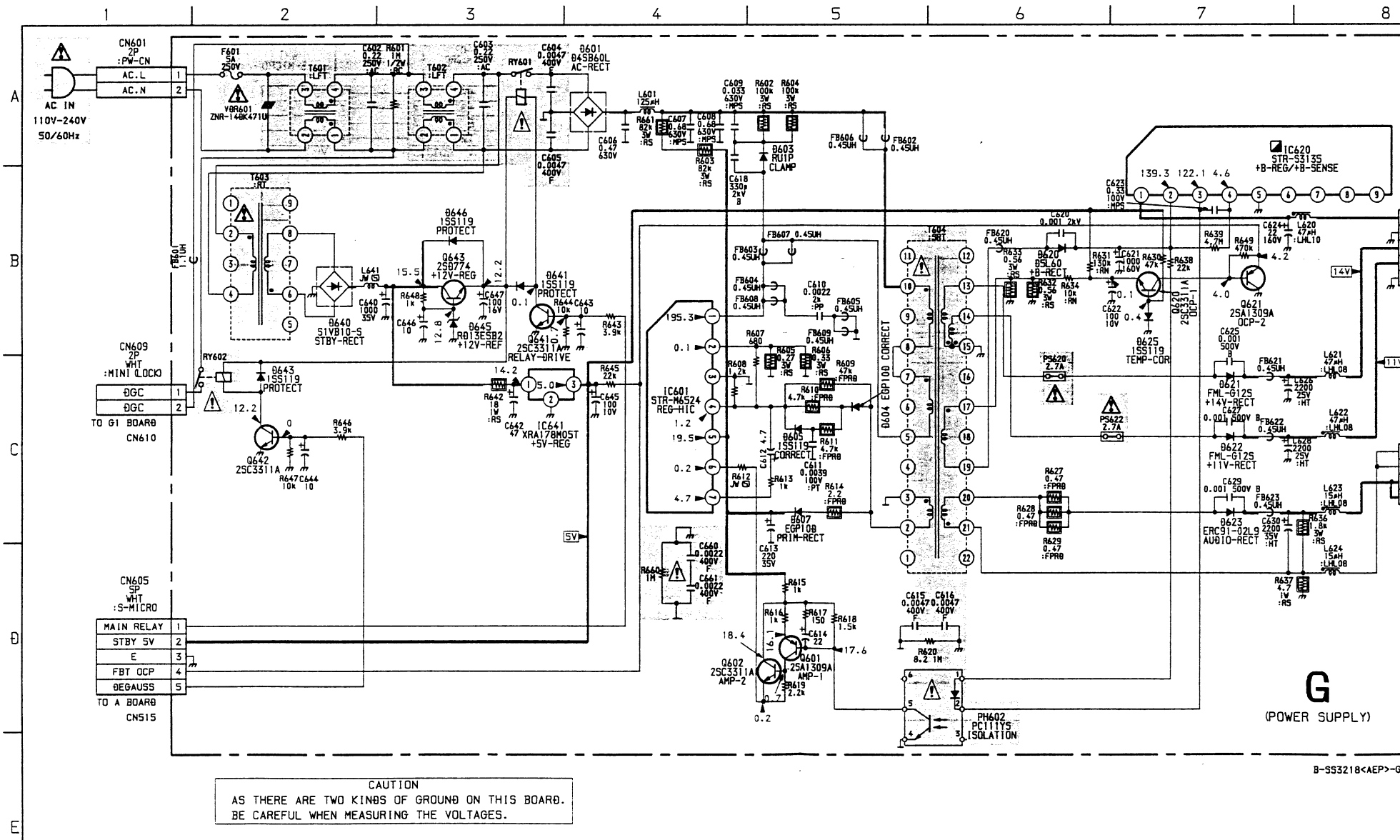

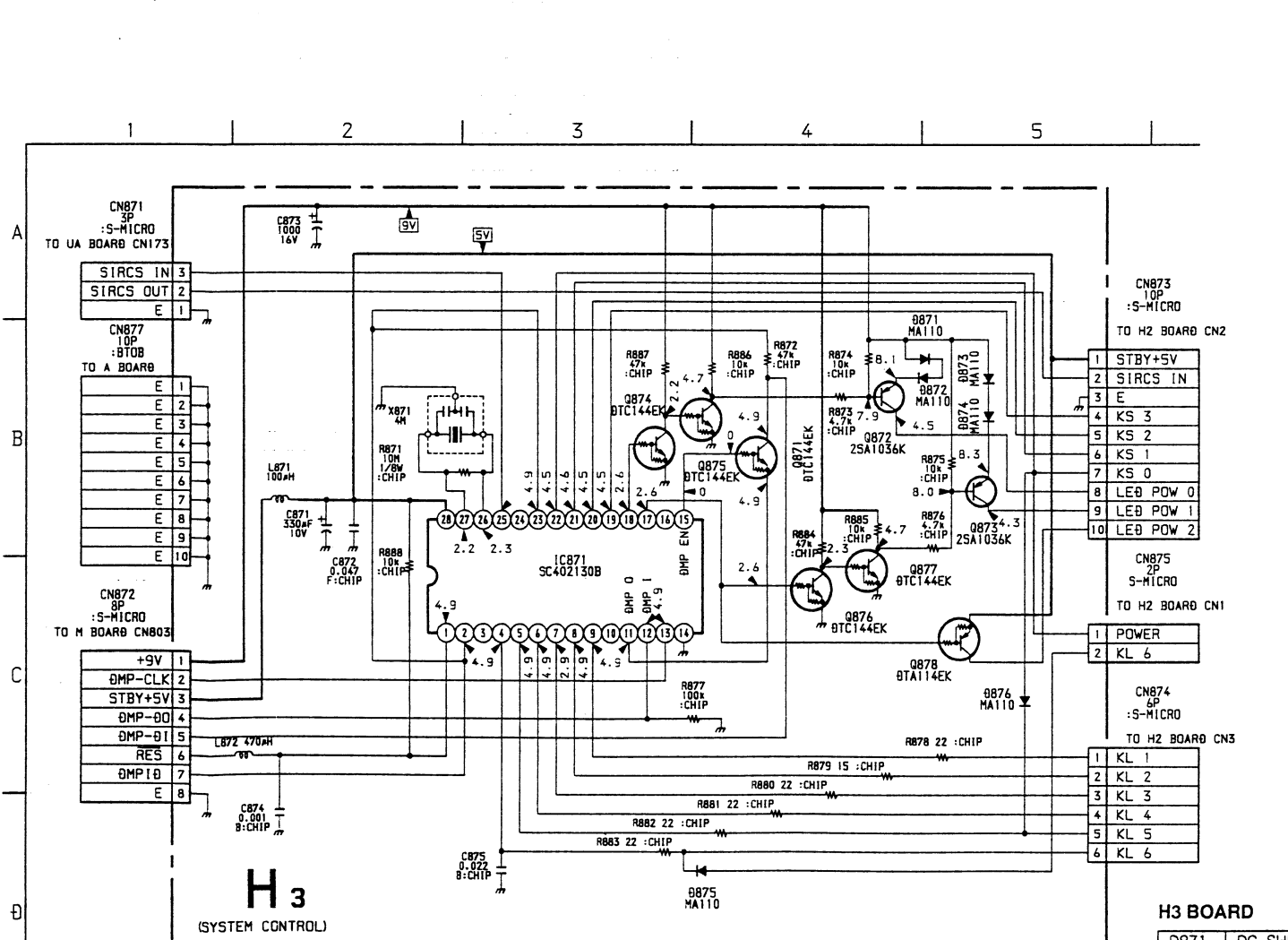
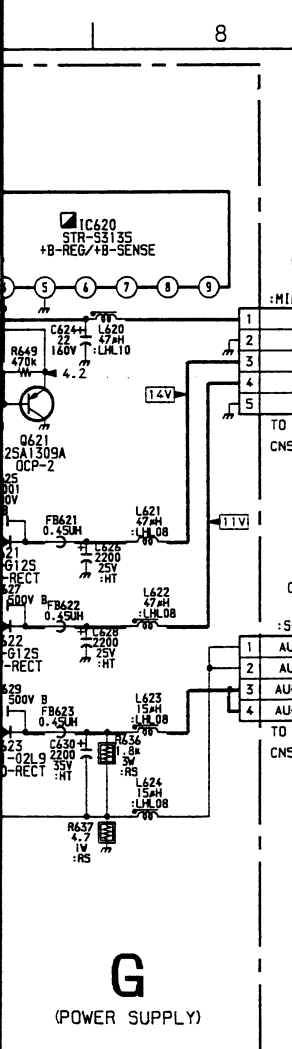
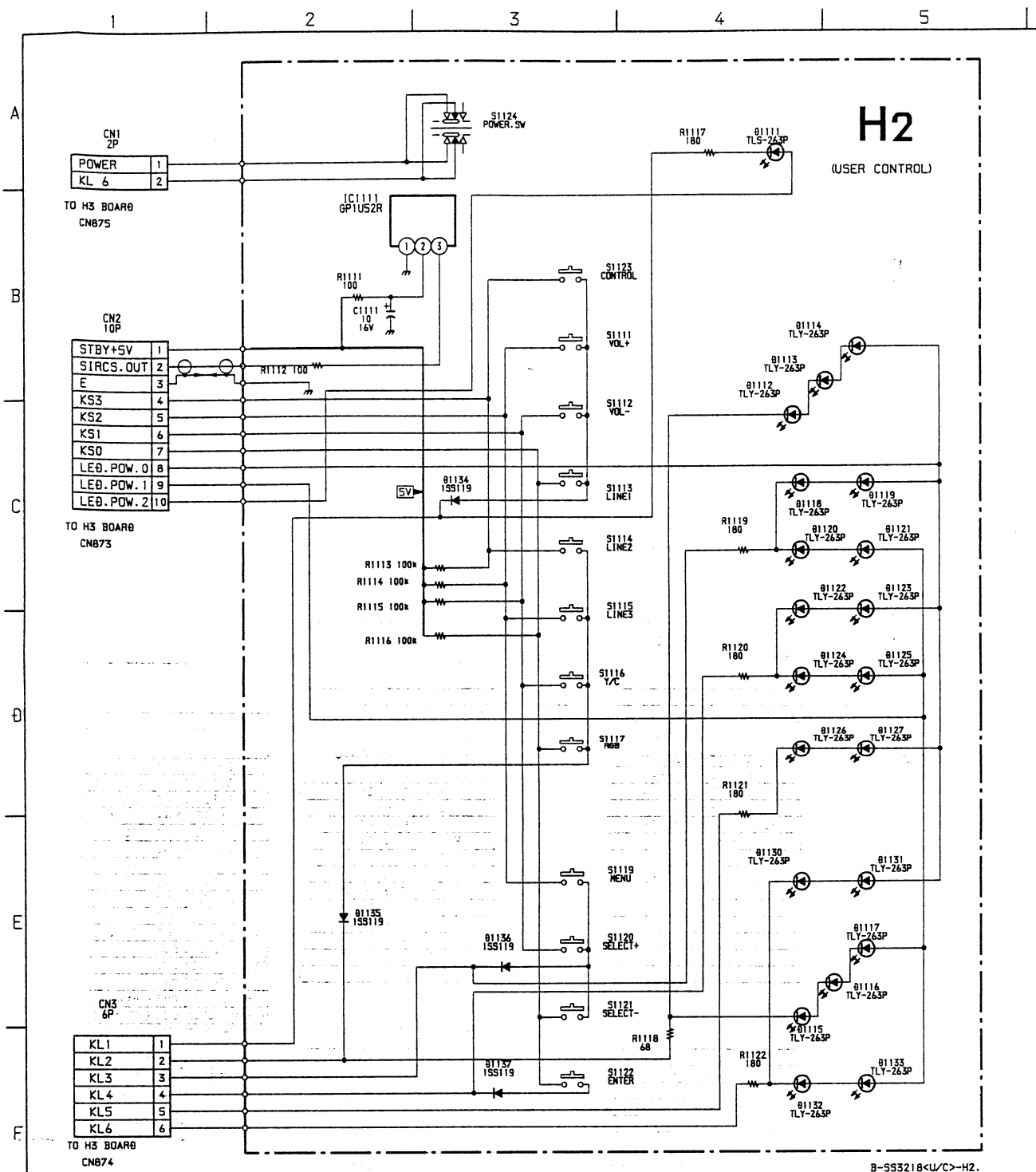
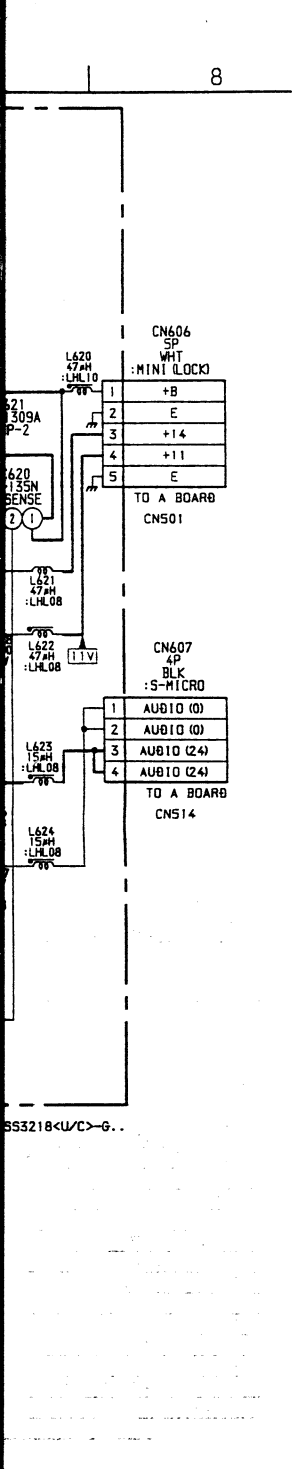

H3 BOARD

D871	DC SHIFT
D872	DC SHIFT
D873	DC SHIFT
D874	DC SHIFT
D875	KEY MATRIX
D876	KEY MATRIX
IC871	SUB MICRO
Q871	INVERT
Q872	LED DRIVER
Q873	LED DRIVER
Q874	INVERT
Q875	INVERT
Q876	INVERT
Q877	INVERT
Q878	LED DRIVER

G [POWER SUPPLY] **H3** [SYSTEM CONTROL] **G1** [DGC] **H2** [USER CONTROL] **VC** [V - PIN Q P]

- G BOARD - (US, Canadian Model)

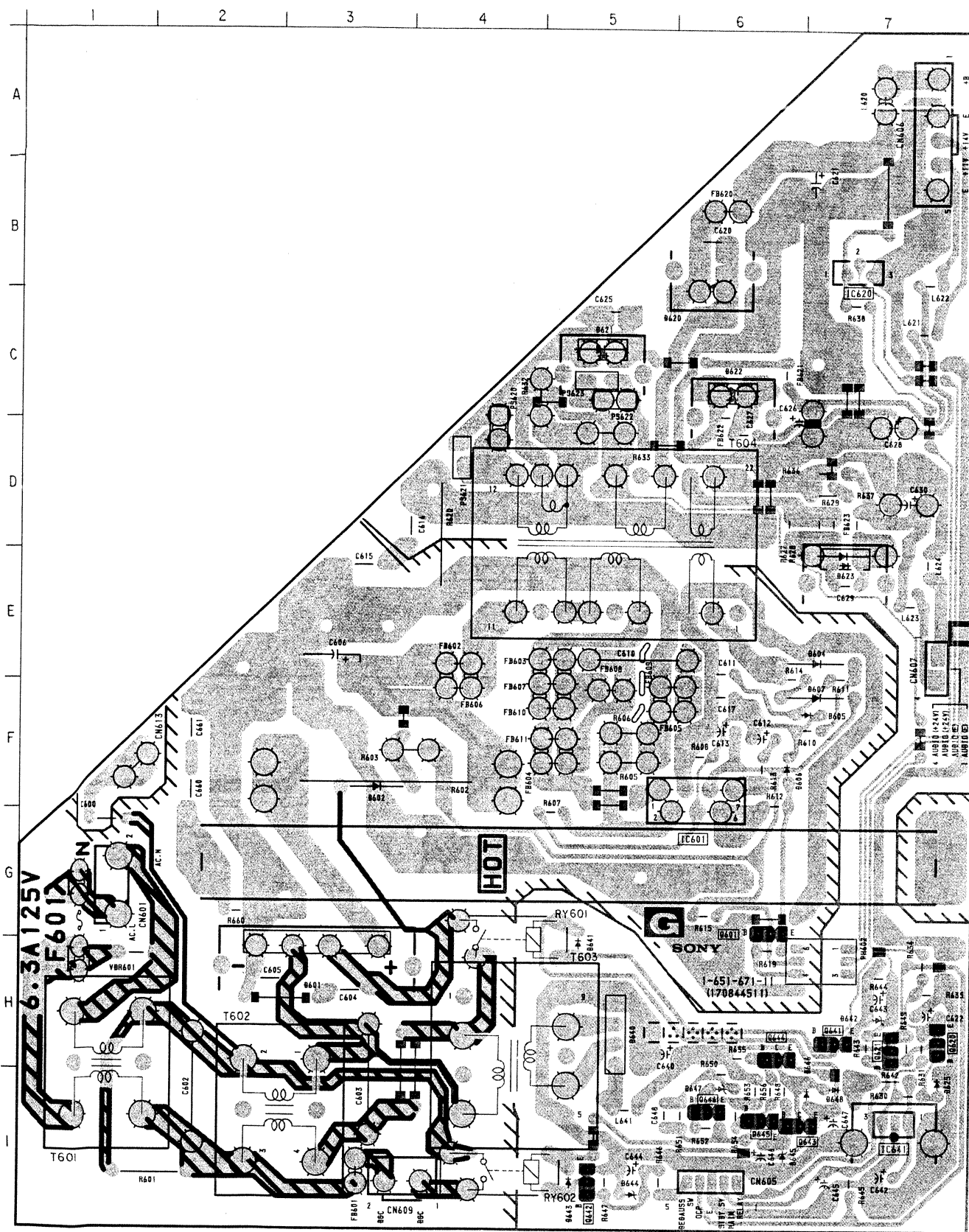

G BOARD

IC	
IC601	F-6
IC620	B-7
IC641	I-7
TRANSISTOR	
Q601	G-6
Q620	H-7
Q621	H-7
Q641	H-7
Q642	I-5
Q643	I-6
Q644	H-6
Q645	I-6
Q646	I-6
DIODE	
D601	H-3
D604	E-7
D605	F-7
D607	F-7
D620	B-6
D621	C-5
D622	C-6
D623	E-7
D625	I-7
D640	H-5
D641	G-5
D643	I-5
D645	I-6
D646	I-7
D647	I-6
D648	I-7

- G BOARD - (AEP, AUS Model)

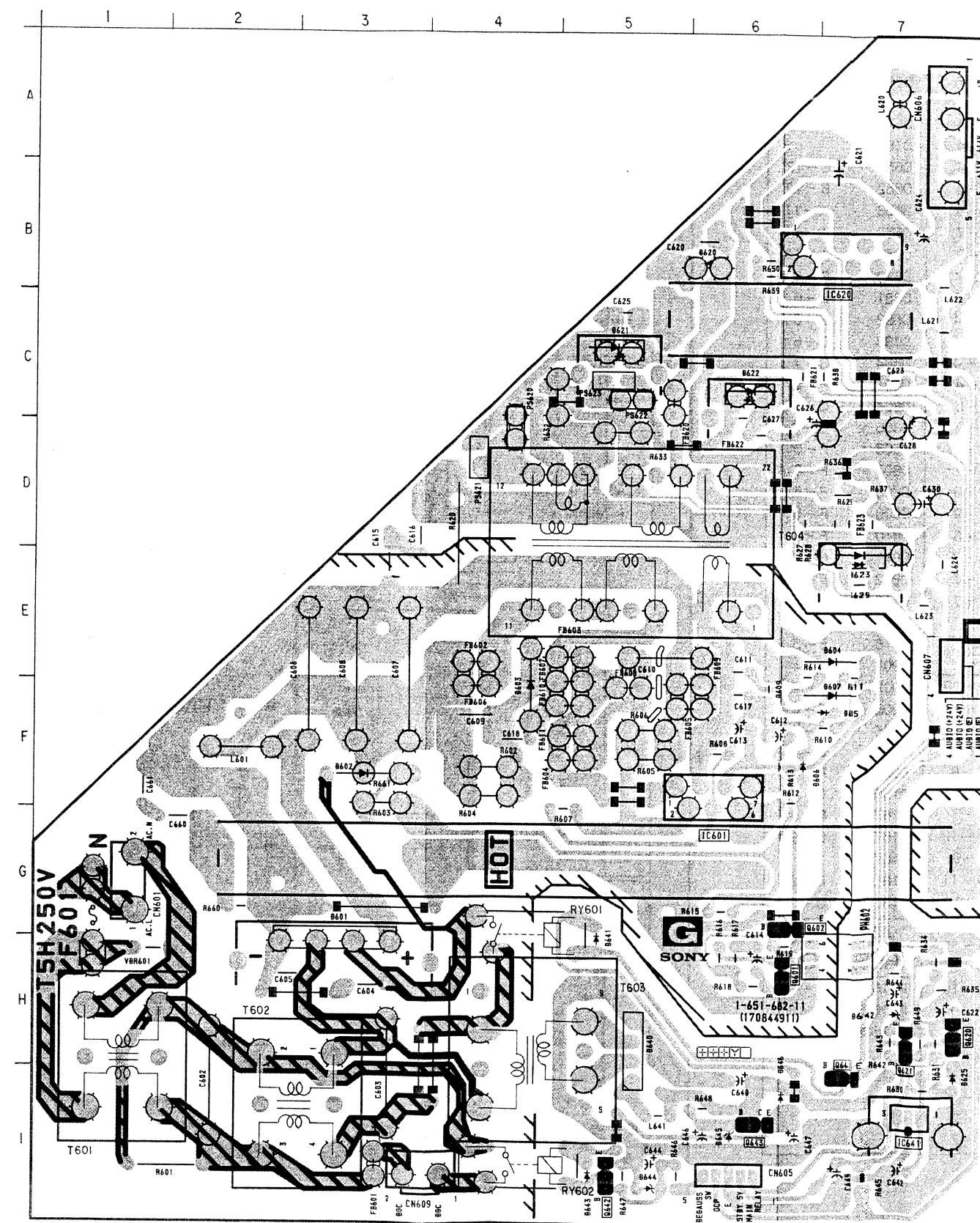

- H3 BOARD -

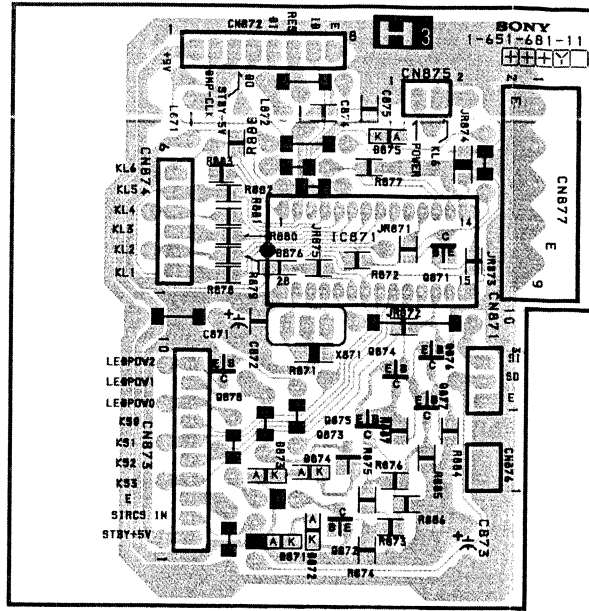

- VC BOARD -

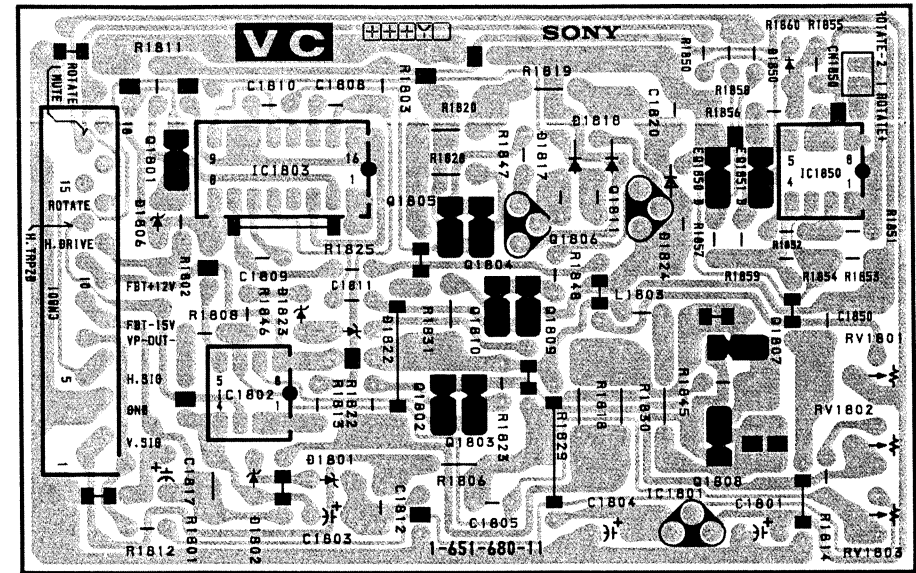

G BOARD

IC	
IC601	F-6
IC620	B-7
IC641	I-7
TRANSISTOR	
Q601	H-6
D602	G-6
Q620	H-7
Q621	H-7
Q641	I-7
Q642	I-5
Q643	I-6
DIODE	
D601	H-3
D603	F-4
D604	E-7
D605	F-7
D607	F-7
D620	B-6
D621	C-5
D622	C-6
D623	E-7
D625	I-7
D640	H-5
D641	G-5
D643	I-5
D645	I-6
D646	I-6

- G1 BOARD - (US, Canadian Model)

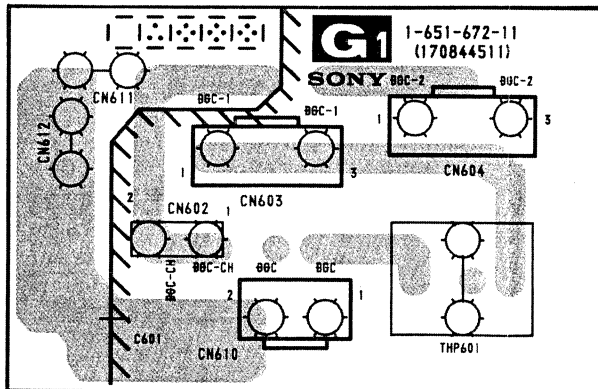

- G1 BOARD - (AEP, AUS Model)

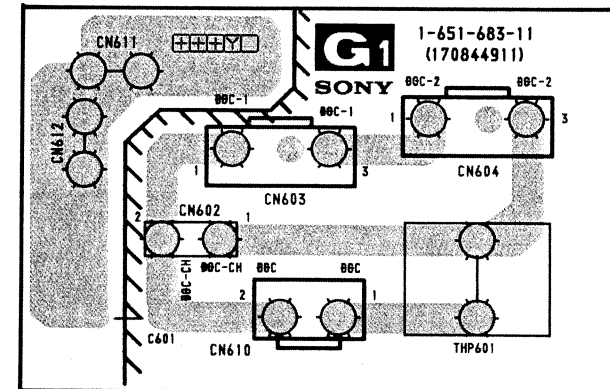

- H2 BOARD -

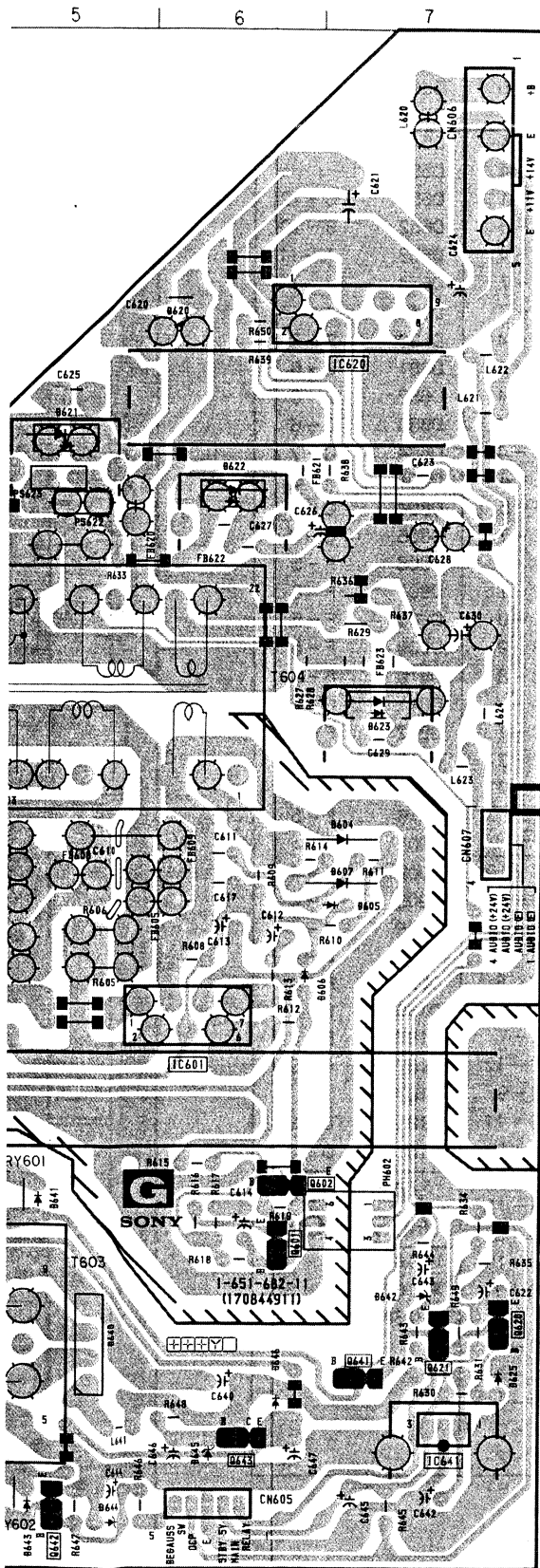
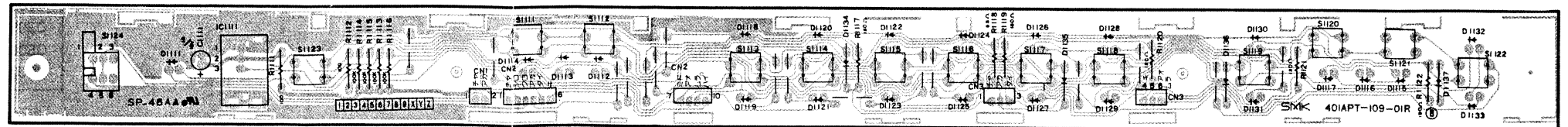

A BOARD

IC		Q808	F-5	D532	E-2
IC501	D-7	Q809	G-6	D533	B-3
IC502	A-10	Q810	G-6	D534	C-3
IC503	C-11	Q811	F-6	D535	D-3
IC504	C-5	Q901	E-4	D542	D-1
IC505	E-2	Q902	F-4	D550	
IC506	A-2	Q903	F-4	D650	C-12
IC507	A-8	Q904	F-4	D652	B-10
IC508	B-4	Q905	C-4	D653	A-11
IC510	A-4	Q806	F-7	D654	A-11
IC511	B-2	Q907	F-7	D655	A-11
IC512	C-12	Q908	G-4	D680	B-6
IC802	E-6	Q909	D-3	D681	B-6
IC803	G-6	Q910	G-4	D682	B-6
IC901	E-4	Q911	D-4	D683	C-6
IC903	D-4	Q912	D-4	D684	C-7
IC1601	B-7	Q913	E-4	D801	F-5
IC1603	A-5	Q914	F-5	D804	G-4
IC1604	B-9	Q1604	B-7	D805	G-4
IC1605	A-9	Q1605	A-7	D806	F-5
		Q1606	B-7	D807	F-6
TRANSISTOR		Q1670	B-9	D808	F-5
Q504	C-10	Q1671	B-9	D809	F-5
Q505	D-10	Q1672	B-8	D810	F-5
Q506	D-11	Q1673	A-7	D811	G-5
Q508	B-11	Q1674	C-7	D812	F-6
Q509	B-11	Q1675	C-7	D813	C-4
Q510	A-11	Q1676	C-7	D814	E-5
Q511	C-11			D816	E-5
Q512	B-11	DIODE		D901	E-4
Q513	C-10	D505	C-10	D902	F-4
Q514	C-11	D506	B-11	D903	F-4
Q515	C-11	D507	B-11	D906	F-4
Q516	G-7	D508	F-7	D907	D-4
Q517	A-4	D509	G-8	D908	F-4
Q518	A-4	D510	F-11	D1601	B-7
Q519	C-4	D511	F-7	D1670	B-9
Q520	C-2	D512	G-12	D1671	B-9
Q521	C-2	D513	E-9	D1672	
Q522	C-2	D515	G-11	D1810	D-8
Q523	C-3	D516	E-10	D1811	D-8
Q530	B-11	D517	B-10	VARIABLE RESISTOR	
Q531	A-1	D519	B-11	RV1601	B-7
Q532	A-5	D520	D-5	RV1602	A-8
Q801	E-6	D521	C-10	RV1603	A-7
Q802	F-5	D522	C-9		
Q803	E-5	D523	F-11		
Q804	F-6	D524	C-9		
Q805	E-5	D525	C-11		
Q806	F-6	D526	B-11		
Q807	F-6	D530	E-2		
		D531	E-2		

NOTE:
The circuit indicated as left contains high voltage of over 600 Vp-p. Care must be paid to prevent an electric shock in inspection or repairing.

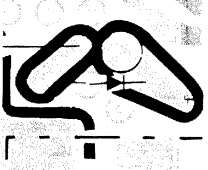
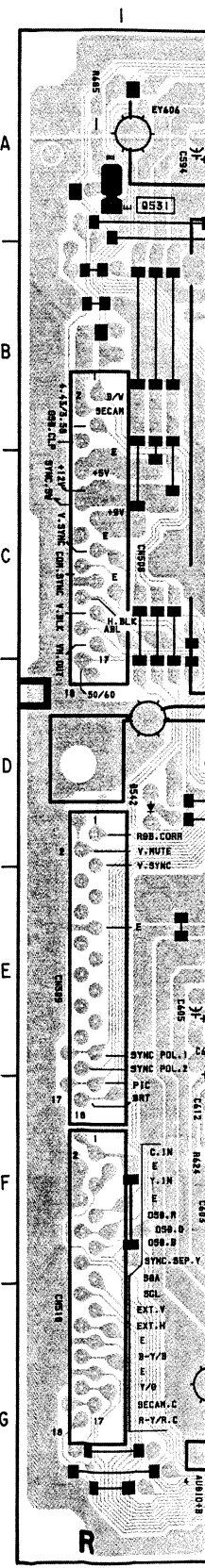



A SYNC OSC, DYNAMIC CONV, H. SFT. CONTROL,
V. PARA. OUT, DQP DRIVE, H/V OUT,
HV PROTECT, AUDIO AMP, DF DRIVE

- A BOARD -

D532	E-2
D533	B-3
D534	C-3
D535	D-3
D542	D-1
D550	
D650	C-12
D652	B-10
D653	A-11
D654	A-11
D655	A-11
D680	B-6
D681	B-6
D682	B-6
D683	C-6
D684	C-7
D801	F-5
D804	G-4
D805	G-4
D806	F-5
D807	F-6
D808	F-5
D809	F-5
D810	F-5
D811	G-5
D812	F-6
D813	C-4
D814	E-5
D816	E-5
D901	E-4
D902	F-4
D903	F-4
D906	F-4
D907	D-4
D908	F-4
D1601	B-7
D1670	B-9
D1671	B-9
D1672	B-9
D1810	D-8
D1811	D-8

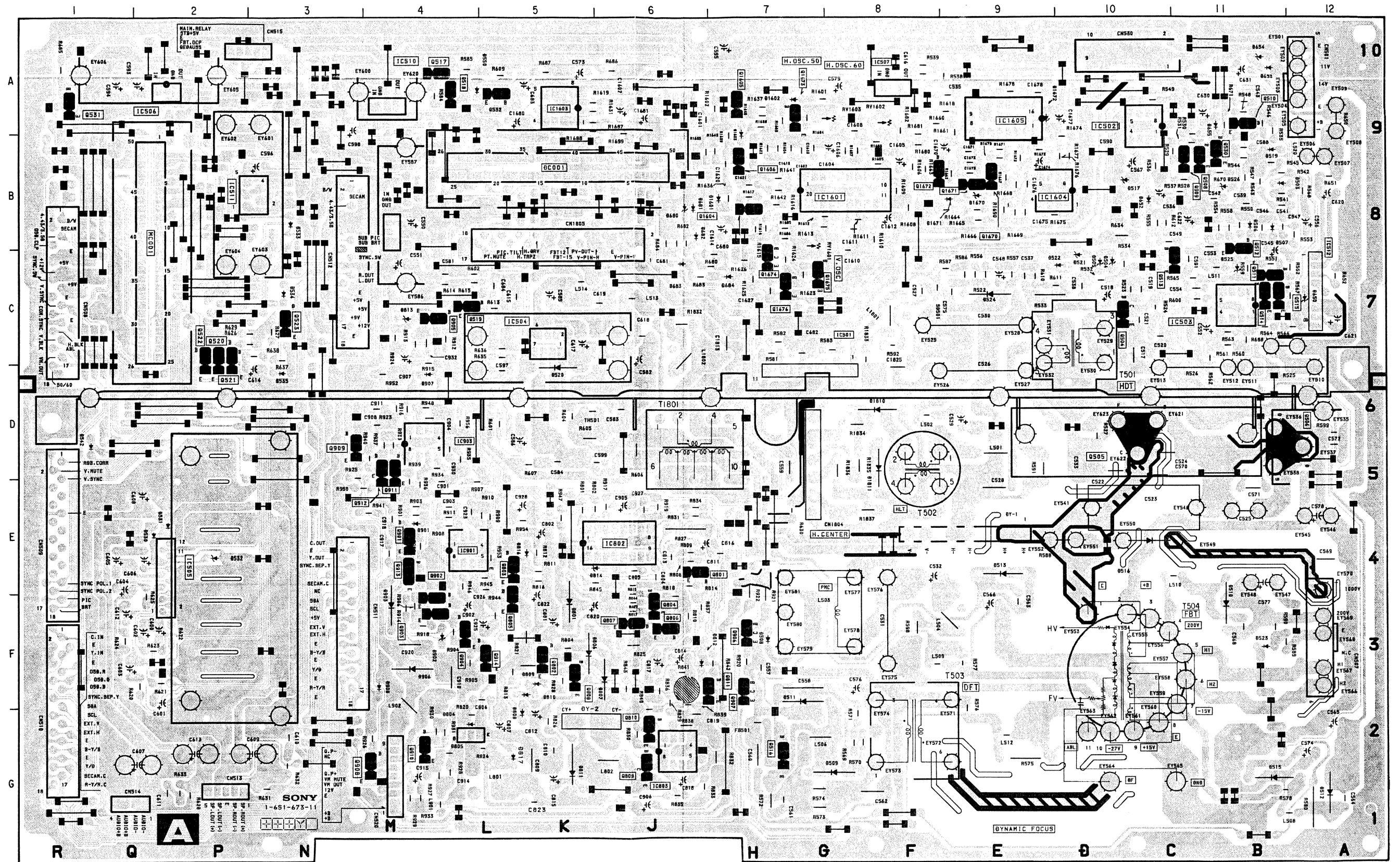
VARIABLE RESISTOR	
RV1601	B-7
RV1602	A-8
RV1603	A-7



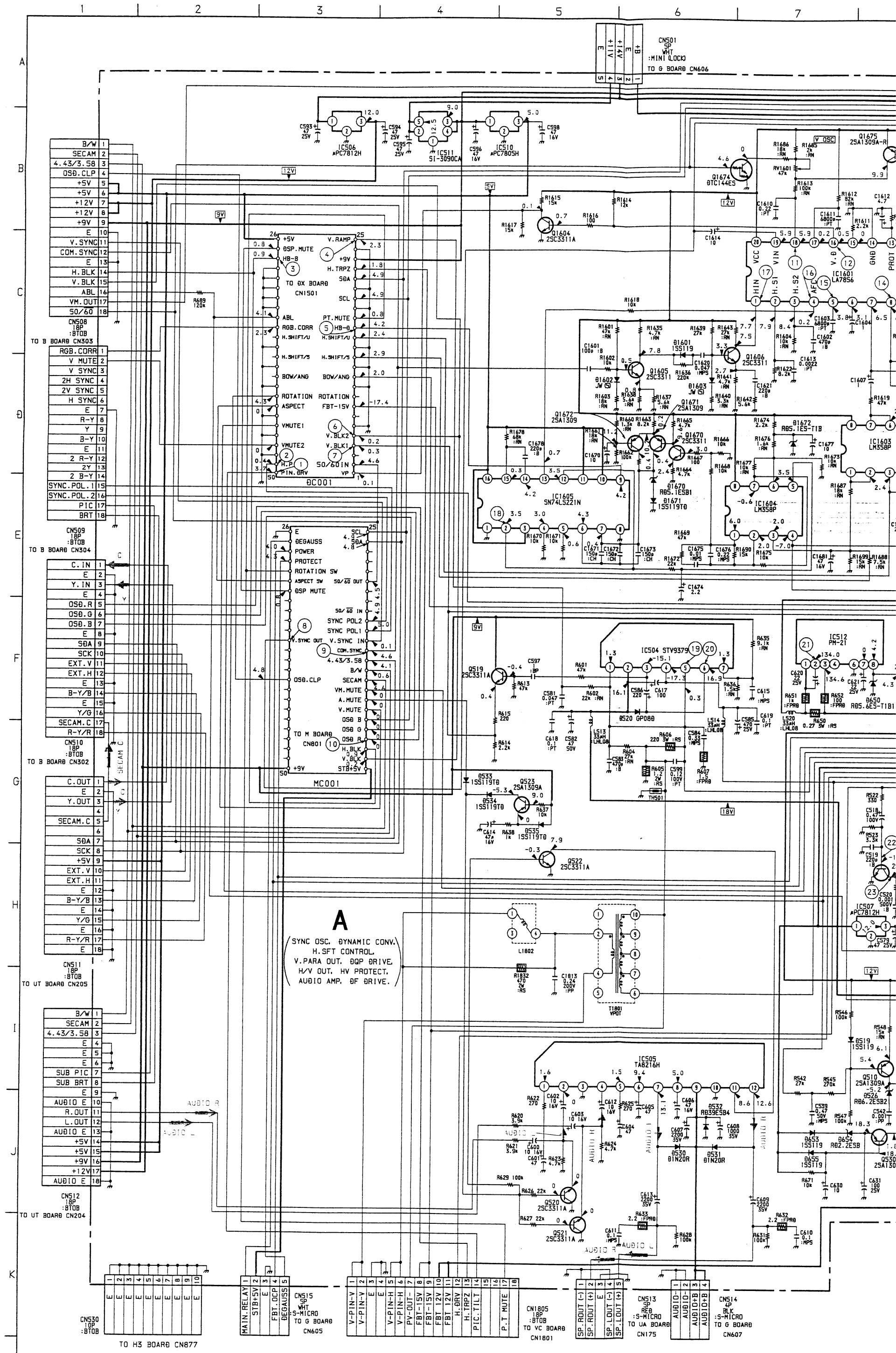

B/W	1
SECAM	2
4.43/3.58	3
OSD.CLP	4
+5V	5
+12V	7
+9V	8
+12V	9
E	10
V. SYNC	11
COM. SYNC	12
E	13
H. BLK	14
V. BLK	15
ABL	16
VM. OUT	17
50/60	18

RGB. CORR	1
V MUTE	2
V SYNC	3
2H SYNC	4
2V SYNC	5
H SYNC	6
E	7
R-Y	8
Y	9
B-Y	10
E	11
2 R-Y	12
2Y	13
2 B-Y	14
SYNC. POL. 1	15
SYNC. POL. 2	16
PIC	17
BRT	18

C. IN	1
E	2
Y. IN	3
E	4
OSD. R	5
OSD. G	6
OSD. B	7
E	8
SDA	9
SCK	10
EXT. V	11
EXT. H	12
E	13
B-Y/B	14
Y/G	15
SECAM. C	17
R-Y/R	18

C. OUT	1
E	2
Y. OUT	3
SECAM. C	4
6	5
SDA	7
SCK	8
+5V	9
EXT. V	10
EXT. H	11
E	12
B-Y/B	13
E	14
R-Y/R	17
E	18

B/W	1
SECAM	2
4.43/3.58	3
E	4
E	5
E	6
SUB PIC	7
SUB BRT	8
E	9
AUDIO E	10
R. OUT	11
L. OUT	12
AUDIO E	13
+5V	14
+5V	15
+9V	16
+12V	17
AUDIO E	18

MAIN RELAY	1
STB+5V	2
E	3
FBT. OCP	4
BEGAUSS	5

A
 (SYNC OSC. DYNAMIC CONV.)
 H. SFT CONTROL
 V. PARA OUT. DQP DRIVE.
 H/V OUT. HV PROTECT.
 AUDIO AMP. OF DRIVE.

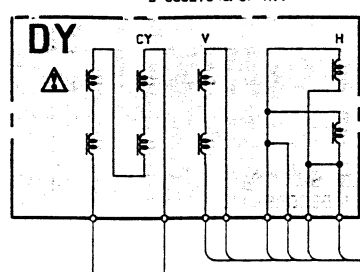
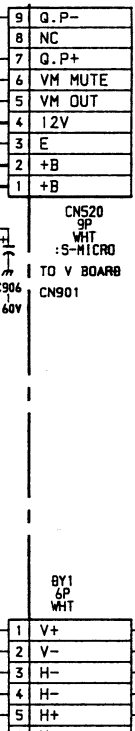
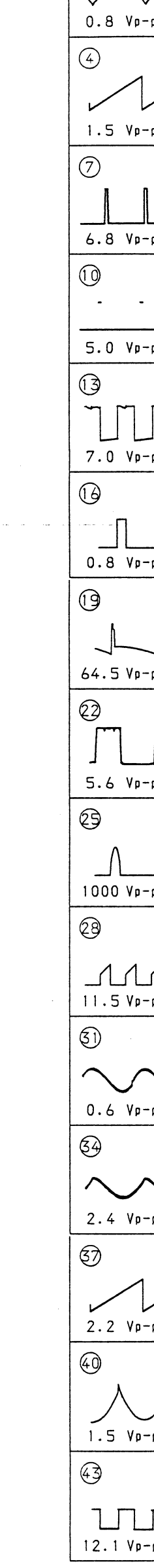
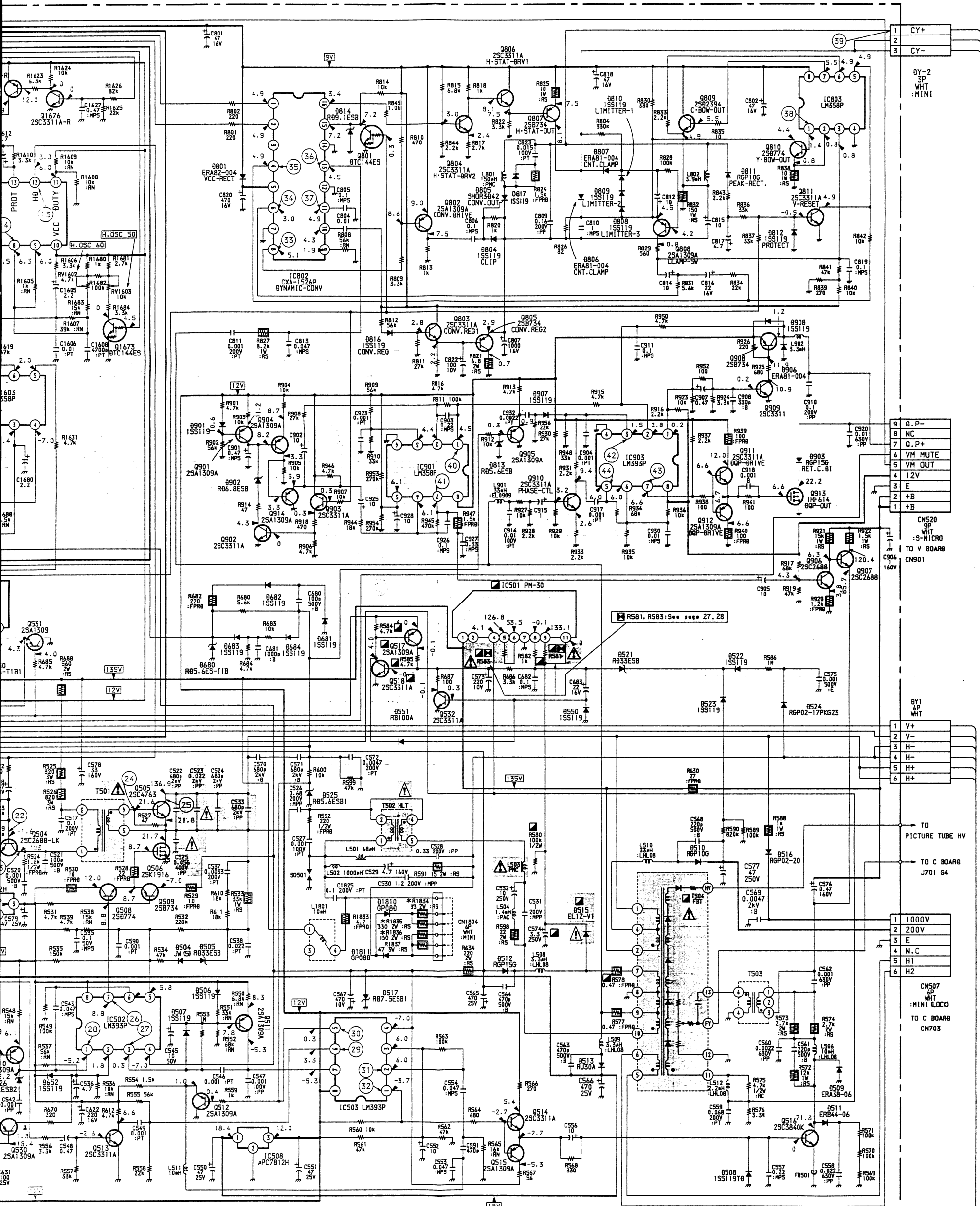

A BOARD

Ref. No.	Location
R1834	H-11
R1835	H-11
R1836	H-11

A BOARD WAVEFORMS

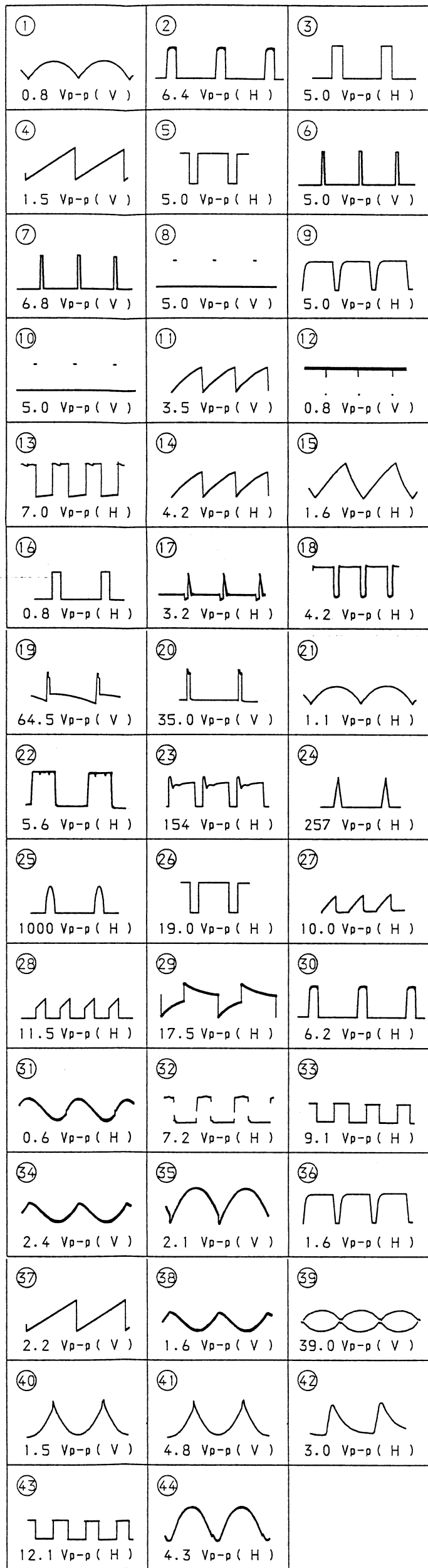

A BOARD

D505	LIMITTER	IC508	12V REG
D506	TEMP CORR	IC510	5V REG
D507	CLAMP	IC511	9V REG
D508	PROTECT	IC512	+ B PROTECT
D509	DF AMP	IC802	D YNAMIC CONV
D510	200V RECT	IC803	F.B.OP AMP
D511	SNUBER	IC901	V PARA OUT
D512	- 15V RECT	IC903	DQP-DRV
D513	15V RECT	IC1601	SYNC OSC
D515	120V RECT	IC1603	AFC CORR
D516	G2 RECT	IC1604	H SFT OUT
D517	REF VOLT	IC1605	H SFT OUT
D519	TEMP CORR		
D520	V BOOST	Q504	H DRIVE
D521	PROTECT 4	Q505	H OUT
D522	PROTECT 5	Q506	PIN OUT
D523	PROTECT 6	Q508	PIN DRV
D524	PEAK RECT	Q509	PIN DRV
D525	H BLK 1	Q510	C SPLY
D526	DC SHIFT	Q511	I SOURCE
D530	PROTECT	Q512	H PLS
D531	PROTECT	Q513	INVERT
D532	PROTECT	Q514	DF OUT 1
D533	SW	Q515	DF OUT 2
D534	SW	Q516	DF OUT
D535	SW	Q517	PROTECT 1
D542	ABL SW	Q518	PROTECT 2
D550	SW	Q519	V BLK OUT
D650	PROTECT	Q520	MUTE
D652	PROTECT	Q521	MUTE
D653	HOLD	Q522	PROTECT
D654	VOLT DROP	Q523	PROTECT
D655	RETURN	Q530	PROTECT
D680	H BLK 2	Q531	PROTECT SW
D681	RECT	Q532	PROTECT 3
D682	FP SW	Q801	H SYNC SW
D683	SW	Q802	CONV DRIVE
D684	BP RECT	Q803	CONV REG 1
D801	VCC RECT	Q804	H STAT DRV 2
D804	CLIP	Q805	CONV REG 2
D805	CONT OUT	Q806	J STAT DRV 1
D806	CNT CLAMP	Q807	H STAT OUT
D807	CNT CLAMP	Q808	CLAMP SW
D808	LIMITTER 3	Q809	C BOW OUT
D809	LIMITTER 2	Q810	Y. BOW OUT
D810	LIMITTER 1	Q811	V RESET
D811	PEAK RECT	Q901	C SPLY
D812	PROTECT	Q902	V PULSE SW
D813	PLS CLIP	Q903	BUFF
D814	PROTECT	Q904	V SAW OUT
D816	CONV REG	Q905	PLS OUT
D901	C SPLY	Q906	DF SOURCE 1
D902	6.8V CLAMP	Q907	DF SOURCE 2
D903	RET C DI	Q908	QP V OUT
D906	QP V OUT	Q909	QP V DRV
D907	S SAW SW	Q910	PHASE CTL
D908	QP V OUT	Q911	DQP DRIVE
O1601	SYNC FILTER	Q912	DQP DRIVE
D1670	PROTECT	Q913	DQP OUT
D1671	PROTECT	Q914	V SAW OUT
D1672	REF VOLT	Q1604	V SYNC OUT
D1810	H CENT 1	Q1605	SYNC DRIVE
D1811	H CENT 2	Q1606	SYNC DRIVE
		Q1670	H S DRV
IC501	HV PROTECT	Q1671	CURR OUT
IC502	PIN CORR	Q1672	PROTECT
IC503	DF DRV	Q1673	FV SW
IC504	V OUT	Q1674	FV SW
IC505	AUDIO AMP	Q1675	SYNC SW
IC506	12V REG	Q1676	SYNC SW
IC507	12V REG		

A BOARD IC1601 LA7856

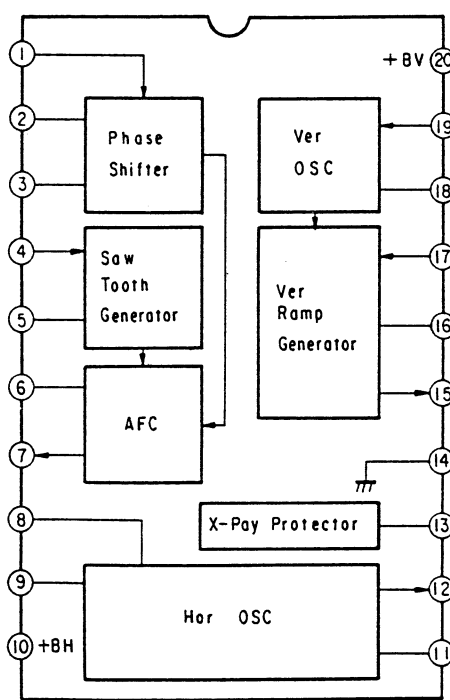

A BOARD * MARK

Ref. No.	Location	PVM-2950Q (U/C) PVM-2950QM (AEP)	PVM-2950QM (AUS)
R1834	H-11	33 2W:RS	0.22 2W:RS
R1835	H-11	330 2W:RS	100 2W:RS
R1836	H-11	150 2W:RS	330 2W:RS

B BOARD

D303	PROTECT
D304	B/W SW
D306	B/W SW
D307	B/W SW
D308	PAL SW
D309	SECAM KILLEY SW
D310	PAL SW
D311	PAL SW
D312	PROTECT
D313	SYSTEM DETECT
D314	SYSTEM DETECT
D315	ABL
D316	
D317	PIC ABL
D318	PROTECT
D319	PROTECT
D320	PROTECT
D321	PROTECT
D322	PROTECT
D323	PROTECT
D324	PROTECT
D325	PROTECT
D326	PROTECT
D327	PROTECT
D328	PROTECT
D329	PROTECT
D331	SYSTEM SW
D333	PROTECT
D334	BLK SW
D335	BLK SW
D336	PROTECT
D337	NO SIGNAL SW
IC301	VIDEO SW
IC302	SYNC SW
IC303	SECAM DECODER
IC304	PAL/SECAM SW
IC305	SYSTEM SW
IC306	NT/PAL DECODER
IC307	PULSE GENELATER
IC308	SYNC SEP
IC309	B/W DETECT
IC310	SYSTEM SW
IC311	D/A CONVERTER
IC312	RGB DECODER
IC313	VIDEO SW
IC316	D/A CONVERTER
IC318	EX OR
IC319	BLUE ONLY SW
IC320	AGING SW
Q301	C BUFF
Q302	Y BUFF
Q303	Y BUFF
Q304	Y BUFF

Q305	Y AMP
Q306	Y BUFF
Q307	Y BUFF
Q308	C BUFF
Q309	C BUFF
Q311	B-Y BUFF
Q312	R-Y BUFF
Q313	B/W SW
Q314	R-Y BUFF
Q315	B-Y BUFF
Q316	14M SW
Q317	17M SW
Q318	VCXO BUFF
Q319	R-Y BUFF
Q320	B-Y BUFF
Q321	BUFF
Q322	INVERT
Q323	V SYNC SEP
Q324	BUFF
Q325	BUFF
Q326	INVERT
Q327	SYNC SEP
Q328	SYNC BUFF
Q329	CLAMP
Q330	SYSTEM DETECT
Q331	BUFF
Q332	VM AMP
Q333	ABL BUFF
Q334	ABL AMP
Q335	ABL
Q336	PIC ABL
Q337	BRT ABL
Q338	R BUFF
Q339	R BUFF
Q340	G BUFF
Q341	G BUFF
Q342	B BUFF
Q343	B BUFF
Q344	INVERT
Q345	SECAM KILLER
Q346	RGB CORR
Q347	NT/PAL SW
Q348	INVERT
Q349	4.43/3.58 SW
Q352	VCXO BUFF
Q354	B GATE SW
Q355	INVERT
Q356	B-Y BUFF
Q357	R-Y BUFF
Q358	MATRIX SW
Q359	Y BUFF
Q360	SW
Q361	BLK SW
Q362	B GATE SW
Q363	NO SIGNAL SW

B BOARD * MARK

REF. NO	PAL	SECAM	NTSC 3.58	NTSC 4.43
IC301 ⑩	11.0	0.1	11.0	11.0
⑬	11.0	0.1	11.0	11.0
⑮	11.0	0.1	11.0	11.0
IC302 ⑨	0.3	0.4	0.6	0.2
⑩	0.2	0.3	0.6	0.2
⑪	0.2	0.4	0.5	0.2
IC303 ⑭	0	3.7	0	0.1
⑯	3.5	2.8	3.5	3.9
IC304 ③	4.5	0	4.6	4.6
IC305 ③	0.8	0.7	0.8	2.5
④	4.1	4.1	4.1	0.3
⑫	3.6	3.6	3.6	2.6
IC306 ④	2.5	1.1	2.5	3.0
⑬	0	0	0	0.9
⑮	4.1	0.1	4.1	4.1
⑯	3.7	3.7	3.7	4.1
⑳	1.2	0.9	0.9	0.6
IC307 ⑤	1.1	4.1	1.1	0.2
⑥	1.1	4.1	1.1	0.2
IC308 ⑦	0.7	1.2	1.2	1.2
⑧	2.7	6.2	6.2	6.2
⑨	3.0	3.0	3.0	2.5
⑲	2.1	3.4	3.4	3.4
IC309 ①	0.6	10.6	0.6	0.4
②	2.5	1.1	2.5	3.0
③	1.7	1.7	1.7	2.1
IC310 ②	3.5	3.7	3.4	2.3
④	1.5	1.5	1.5	2.9
⑤	5.0	5.0	5.0	2.9
⑥	4.0	4.1	4.0	0.3
⑩	4.1	4.1	4.0	0.3
⑪	4.1	4.1	4.0	0.3
⑫	5.0	5.0	4.0	2.9
⑬	1.8	1.8	1.8	2.9
IC311 ①	0	11.9	0.6	0.6
②	0.2	11.1	0.2	0.2
③	4.6	4.1	4.1	4.6
④	0	11.9	4.6	4.6
⑤	4.6	0.1	4.6	4.6
⑥	4.6	0	4.6	4.6
⑦	0	0	0	8.0
⑯	4.9	3.4	0.1	4.9
⑰	4.9	4.1	4.9	4.5
IC312 ⑳	6.4	6.7	6.7	7.6
㉑	6.8	7.5	7.6	8.2
㉒	7.0	7.4	7.4	8.6
IC316 ②	0	2.5	0	0
③	0.4	0.9	0.4	0.4
④	1.9	0.2	0	0
⑤	7.4	0.2	7.4	7.4
⑥	1.8	0	1.8	1.8
⑦	5.7	0	5.7	5.7
⑩	0	2.4	4.9	4.9
⑰	0	2.5	4.9	4.9
IC318 ②	4.8	4.8	4.7	1.0
④	5.0	0	5.0	5.0
⑤	3.7	3.5	3.4	4.6
⑥	0.4	4.6	0.5	0.2
⑩	0	0.3	0.3	0.3
⑪	0	0.3	0.3	0.3
⑰	0	0.6	0.7	0.6
IC319 ③	0	0.9	0.9	2.8
Q313 B	-0.4	0.5	-0.5	0.1
C	4.9	0	4.9	4.9
Q319 B	1.8	1.8	1.8	1.9
E	2.4	2.4	2.4	3.5
Q320 B	1.5	1.5	1.5	1.0
E	2.1	2.1	2.1	0
Q324 B	1.8	1.8	1.8	1.8
Q330 B	2.0	0	1.9	0.9
C	4.9	0.3	4.9	0
E	4.8	4.1	4.8	4.6
Q344 B	0	3.7	0	0
C	11.0	0.1	11.0	11.0
Q345 B	2.4	0.7	2.4	2.4
C	0	3.7	0	0
Q347 B	4.0	4.1	4.1	0.3
C	0	0	0	0.9
Q348 B	0	3.7	0	0
C	4.6	0.1	0	4.6
Q354 C	0.8	0	0.9	0.7
E	0	1.8	0	0
Q356 B	3.8	3.7	4.0	2.3
E	5.0	5.0	5.0	2.9
Q357 B	3.8	3.8	3.6	2.3
E	5.0	5.0	5.0	2.9
Q358 C	0.9	1.2	1.2	0.5
Q361 B	0.1	1.8	0.2	0.1
C	4.1	0.1	4.1	4.1
Q363 B	0.5	0.5	0.4	0.1
C	2.6	1.1	2.6	3.0

B BOARD WAVEFORMS

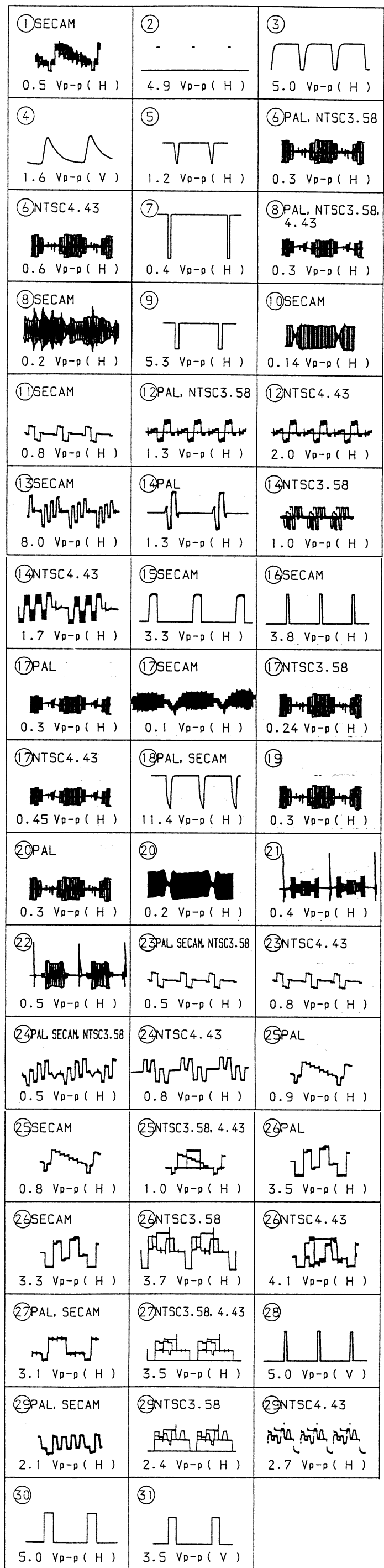

B BOARD IC308 M520365SP

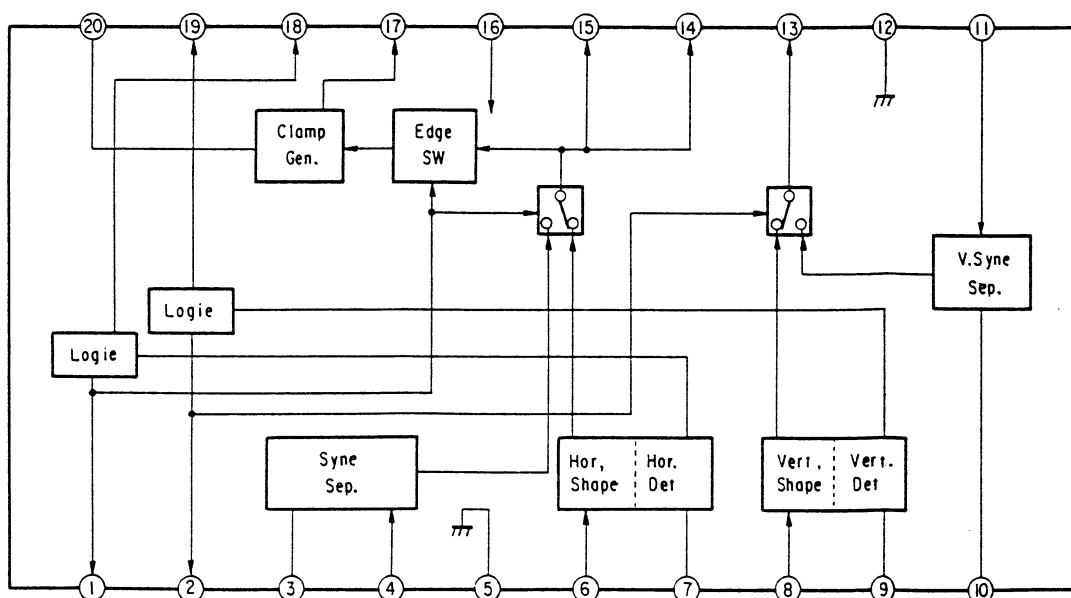

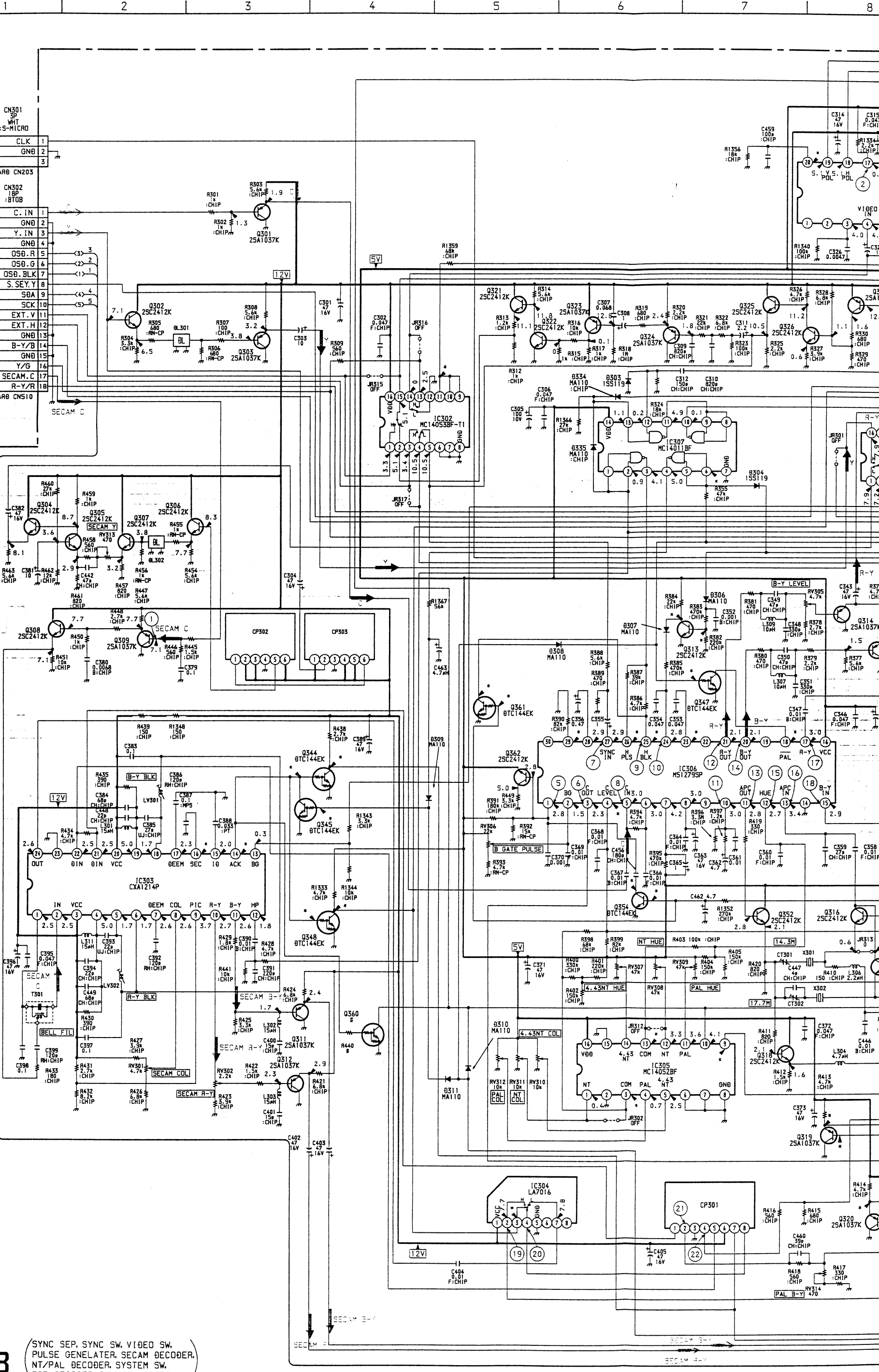

- ③ 5.0 Vp-p (H)
- ⑥ PAL, NTSC3.58 0.3 Vp-p (H)
- ⑧ PAL, NTSC3.58, 4.43 0.3 Vp-p (H)
- ⑩ SECAM 0.14 Vp-p (H)
- ⑫ NTSC4.43 2.0 Vp-p (H)
- ⑭ NTSC3.58 1.0 Vp-p (H)
- ⑯ SECAM 3.8 Vp-p (H)
- ⑰ NTSC3.58 0.24 Vp-p (H)
- ⑲ 0.3 Vp-p (H)
- ⑳ 0.4 Vp-p (H)
- ㉓ NTSC4.43 0.8 Vp-p (H)
- ㉕ PAL 0.9 Vp-p (H)
- ㉖ PAL 3.5 Vp-p (H)
- ㉗ NTSC4.43 4.1 Vp-p (H)
- ㉘ 5.0 Vp-p (V)
- ㉙ NTSC4.43 2.7 Vp-p (H)

B (SYNC SEP. SW. VIDEO SW. PULSE GENERATOR, SECAM DECODER, NT/PAL DECODER, SYSTEM SW. RGB DECODER, A/B CONVERTER.)

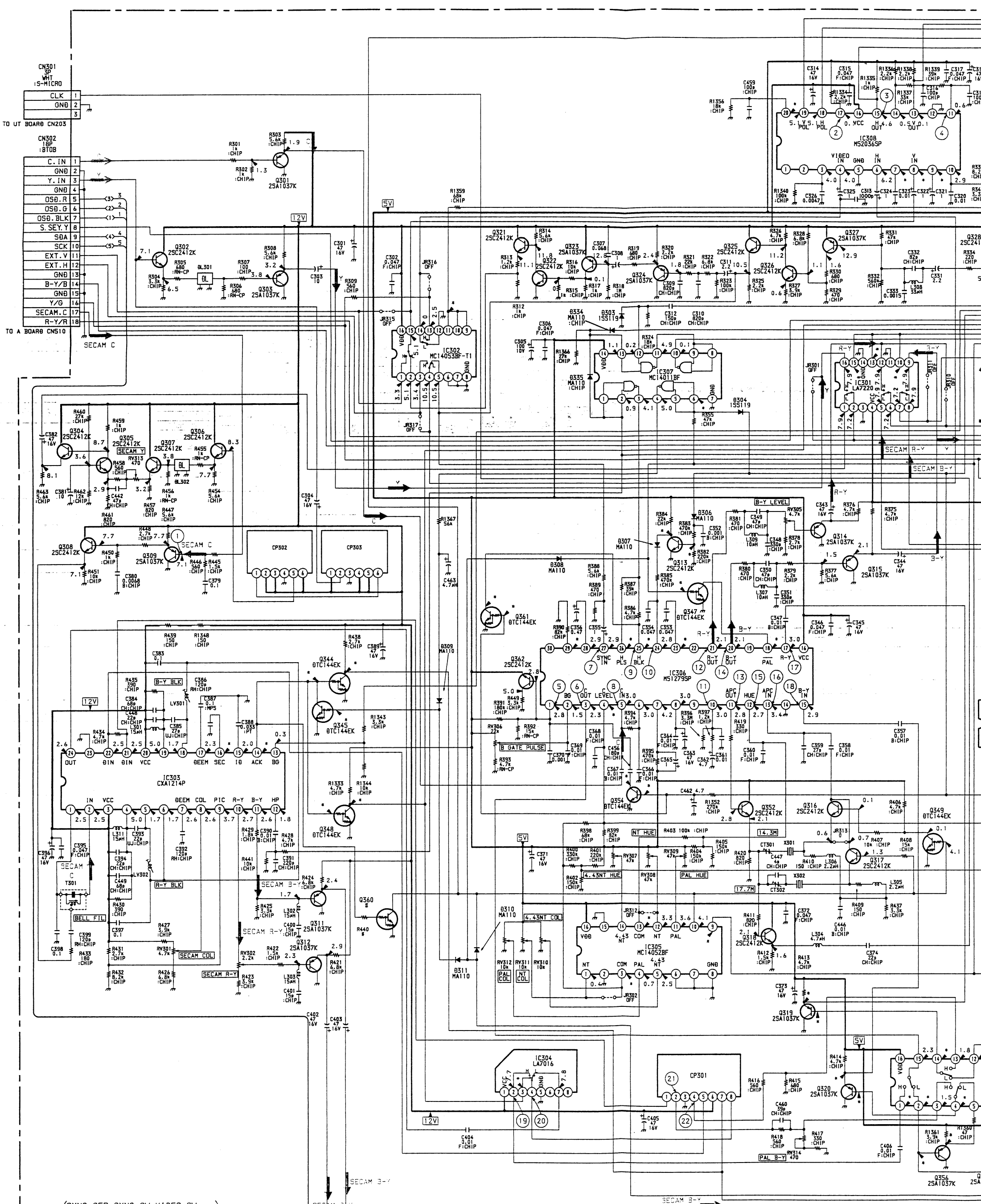

B (SYNC SEP. SYNC SW. VIDEO SW. PULSE GENELATER. SECAM DECODER. NT/PAL DECODER. SYSTEM SW. RGB DECODER. D/A CONVERTER.)

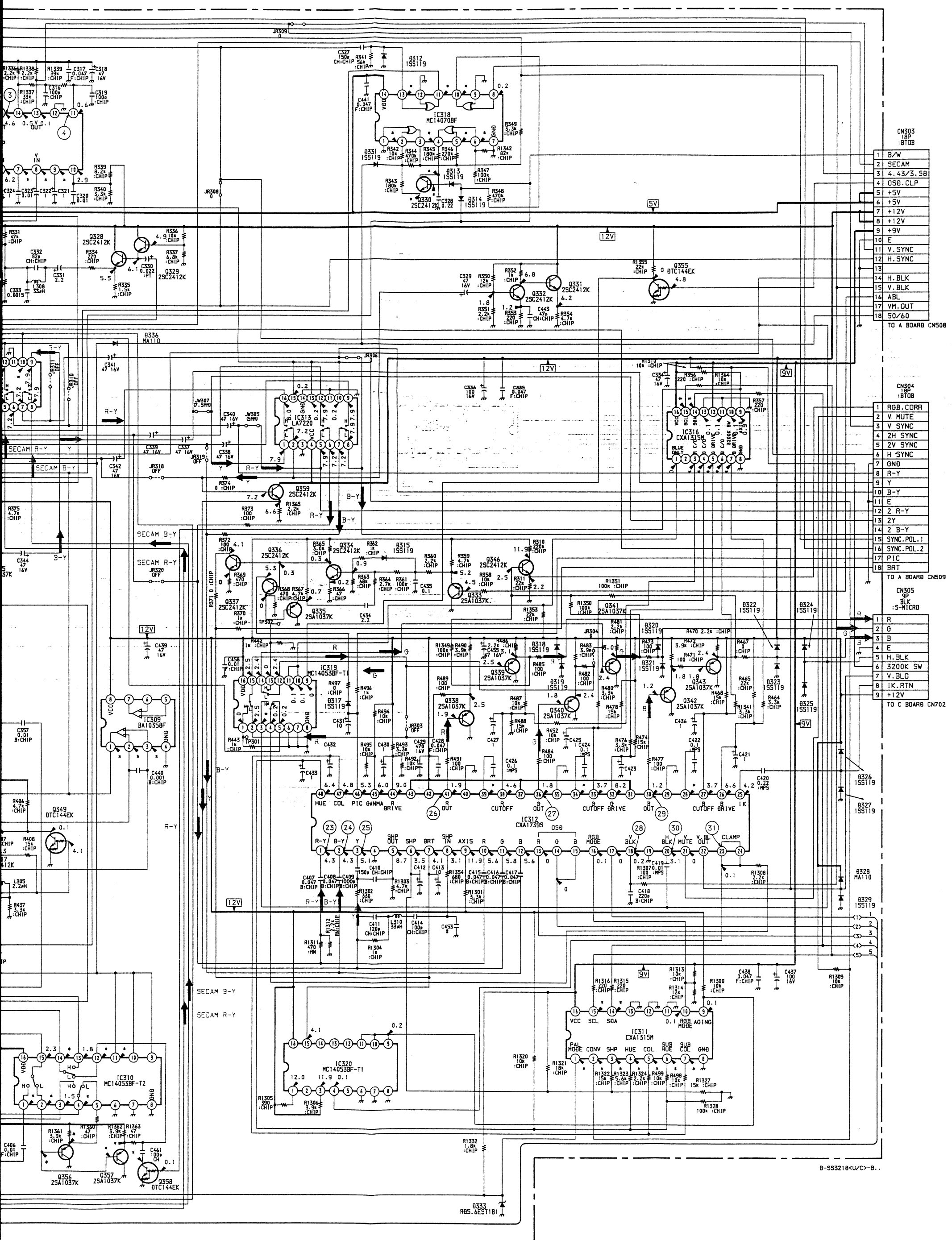

CN303
18P
:BT0B

1	B/W
2	SECAM
3	4.43/3.58
4	DSB.CLP
5	+5V
6	+5V
7	+12V
8	+12V
9	+9V
10	E
11	V. SYNC
12	H. SYNC
13	
14	H. BLK
15	V. BLK
16	ABL
17	VM. OUT
18	50/60

TO A BOARD CN508

CN304
18P
:BT0B

1	RGB. CORR
2	V MUTE
3	V SYNC
4	2H SYNC
5	2V SYNC
6	H SYNC
7	GND
8	R-Y
9	Y
10	B-Y
11	E
12	2 R-Y
13	2Y
14	2 B-Y
15	SYNC.POL.1
16	SYNC.POL.2
17	PIC
18	BRT

TO A BOARD CN509

CN305
9P
:S-MICRO

1	R
2	G
3	B
4	E
5	H. BLK
6	320K SW
7	V. BLO
8	1K. RTN
9	+12V

TO C BOARD CN702

B-553218<U/C>-B..

B SYNC SEP, SYNC SW, VIDEO SW, PULSE GENELATER, SECAM DECODER, NT/PAL DECODER, SYSTEM SW, RGB DECODER, D/A CONVERTER,

- B BOARD -

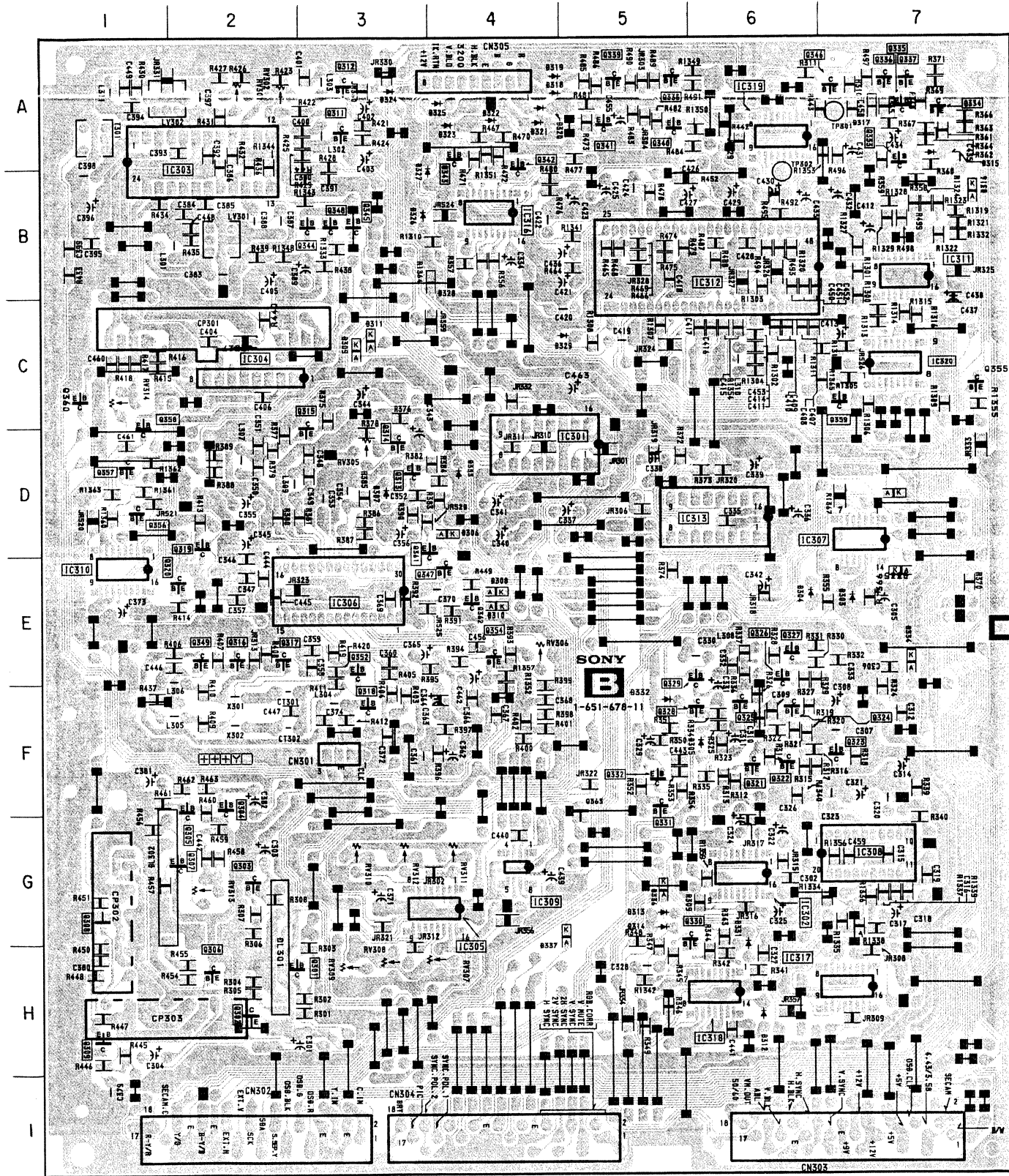

B BOARD

IC		TRANSISTOR		DIODE	
IC301	D-4	Q301	H-2	D303	E-7
IC302	G-6	Q302	H-2	D304	E-6
IC303	A-1	Q303	G-2	D306	D-3
IC304	C-2	Q304	F-2	D307	D-3
IC305	G-3	Q305	F-1	D308	E-4
IC306	E-3	Q306	H-2	D309	C-3
IC307	D-7	Q307	G-1	D310	E-4
IC308	G-7	Q308	G-1	D311	C-3
IC309	G-4	Q309	H-1	D312	H-6
IC310	E-1	Q311	A-3	D313	G-5
IC311	B-7	Q312	A-3	D314	G-5
IC312	B-5	Q313	D-3	D315	A-7
IC313	D-5	Q314	D-3	D316	B-7
IC316	B-4	Q315	D-2	D317	A-7
IC318	H-6	Q316	E-2	D318	A-4
IC319	A-6	Q317	E-2	D319	A-4
IC320	C-7	Q318	F-3	D320	A-4
		Q319	D-2	D321	A-4
		Q320	E-1	D322	A-4
		Q321	F-6	D323	A-3
		Q322	F-6	D324	A-3
		Q323	F-7		
		Q324	F-6		
		Q325	F-6		
		Q326	E-6		
		Q327	E-6		
		Q328	F-5		
		Q329	E-5		
		Q330	G-5		
		Q331	F-5		
		Q332	F-5		
		Q333	A-7		
		Q334	A-7		
		Q335	A-7		
		Q336	A-7		
		Q337	A-7		
		Q338	A-5		
		Q339	A-5		
		Q340	A-5		
		Q341	A-5		
		Q342	A-4		
		Q343	A-4		
		Q344	B-2		
		Q345	B-3		
		Q346	A-6		
		Q347	E-3		
		Q348	B-3		
		Q349	E-2		
		Q352	E-3		
		Q354	E-4		
		Q355	C-7		
		Q356	D-1		
		Q357	D-1		
		Q358	C-1		
		Q359	C-7		
		Q360	C-1		
		Q361	D-3		
		Q362	E-4		
		D325	A-3		
		D326	B-3		
		D327	A-3		
		D328	B-3		
		D329	C-4		
		D331	G-6		
		D333	D-4		
		D334	E-7		
		D335	E-7		
		D336	G-5		

B BOARD IC311 CXA1315M

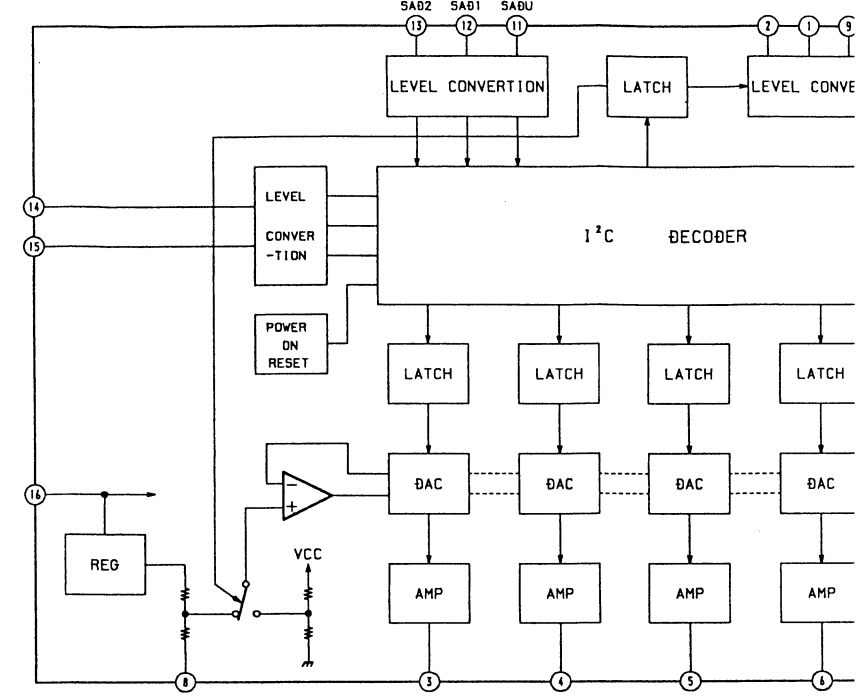

V [VM AMP] **DX** [SYSTEM CONT] **M** [CPU, MEM]

- V BOARD -

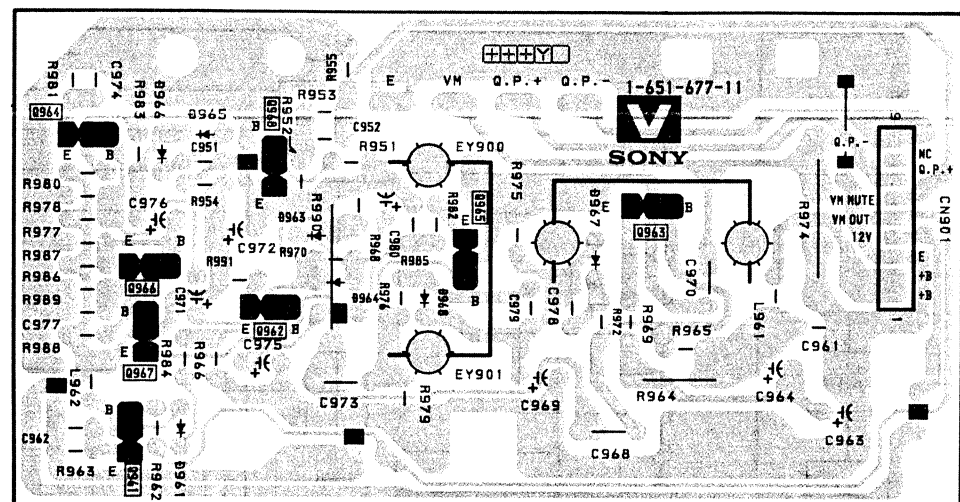

- DX BOARD - (Component Side)

DX BOARD

IC	
IC1501	C-1
IC1502	B-1
IC1503	A-2
IC1504	B-2
IC1505	C-2
IC1506	C-3
IC1507	A-3
IC1508	A-3
IC1509	B-3
IC1511	A-3
IC1514	B-3
IC1516	B-3
IC1518	B-3
IC1590	B-3
DIODE	
Q1501	F-4
Q1502	E-4
Q1503	D-4
Q1504	D-3
Q1590	F-2
Q1591	E-2
TRANSISTOR	
D1501	D-4
D1502	B-3
D1505	D-1
D1506	D-2
D1507	E-1
D1508	E-2
D1590	E-3
D1591	E-2

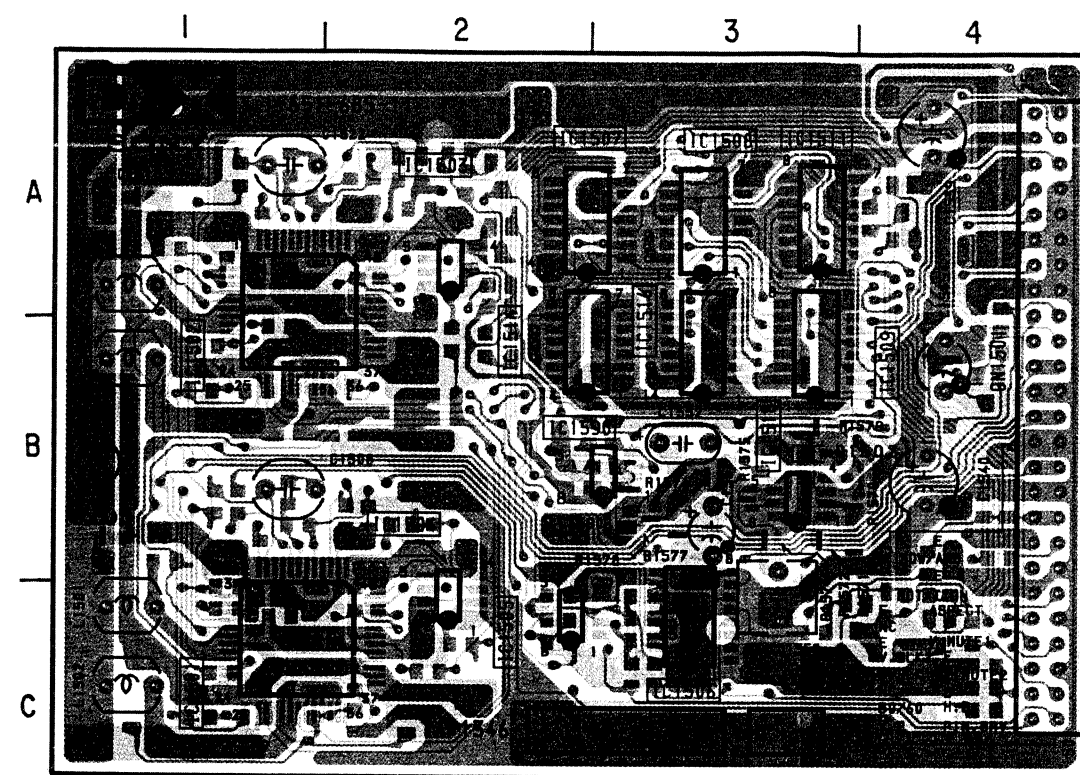

(Conductor Side)

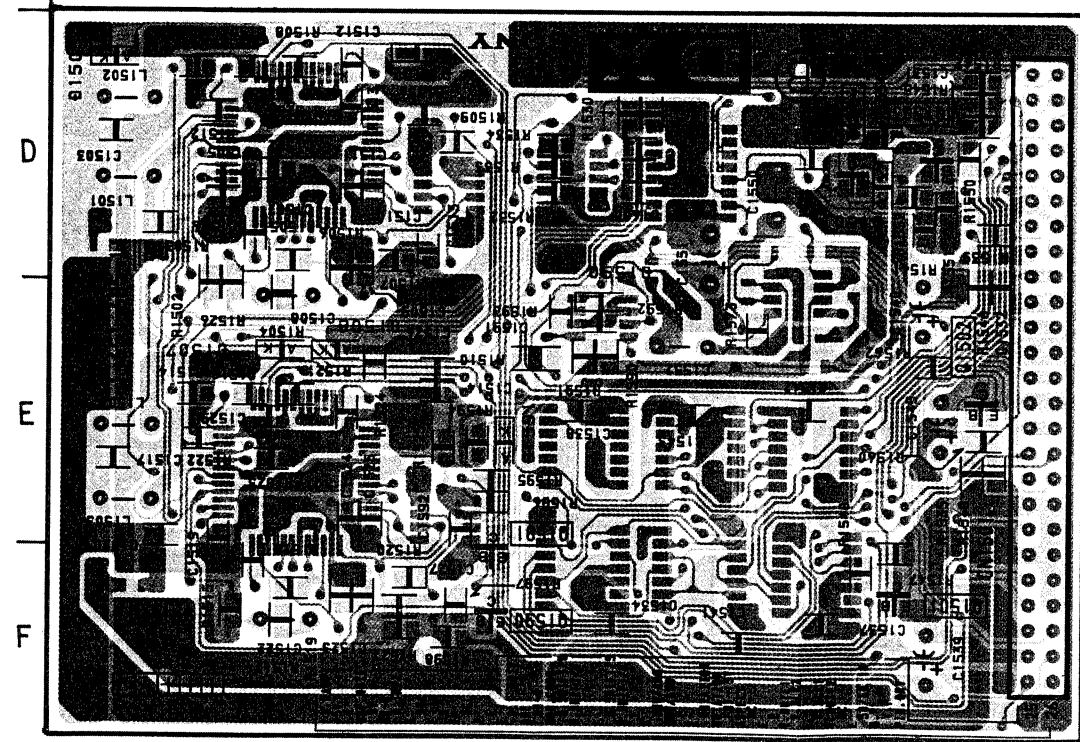

M BOARD

IC	
IC801	A-2, E-2
C802	B-4
IC803	B-4
IC804	B-1
IC805	B-3
IC806	C-2
DIODE	
D801	A-4
D802	E-3
D803	A-4
D804	E-3
D805	D-1
D806	D-1
D807	D-1
D808	C-1
D809	C-3
D810	D-1
D811	D-3
D812	E-3
D813	D-3
D814	E-3

Note :

- [Pattern from the side which enables seeing.]
- [Pattern of the rear side.]

- DX BOARD - (Component Side)

DX BOARD

IC	
IC1501	C-1
IC1502	B-1
IC1503	A-2
IC1504	B-2
IC1505	C-2
IC1506	C-3
IC1507	A-3
IC1508	A-3
IC1509	B-3
IC1511	A-3
IC1514	B-3
IC1516	B-3
IC1518	B-3
IC1590	B-3
DIODE	
Q1501	F-4
Q1502	E-4
Q1503	D-4
Q1504	D-3
Q1590	F-2
Q1591	E-2
TRANSISTOR	
D1501	D-4
D1502	B-3
D1505	D-1
D1506	D-2
D1507	E-1
D1508	E-2
D1590	E-3
D1591	E-2

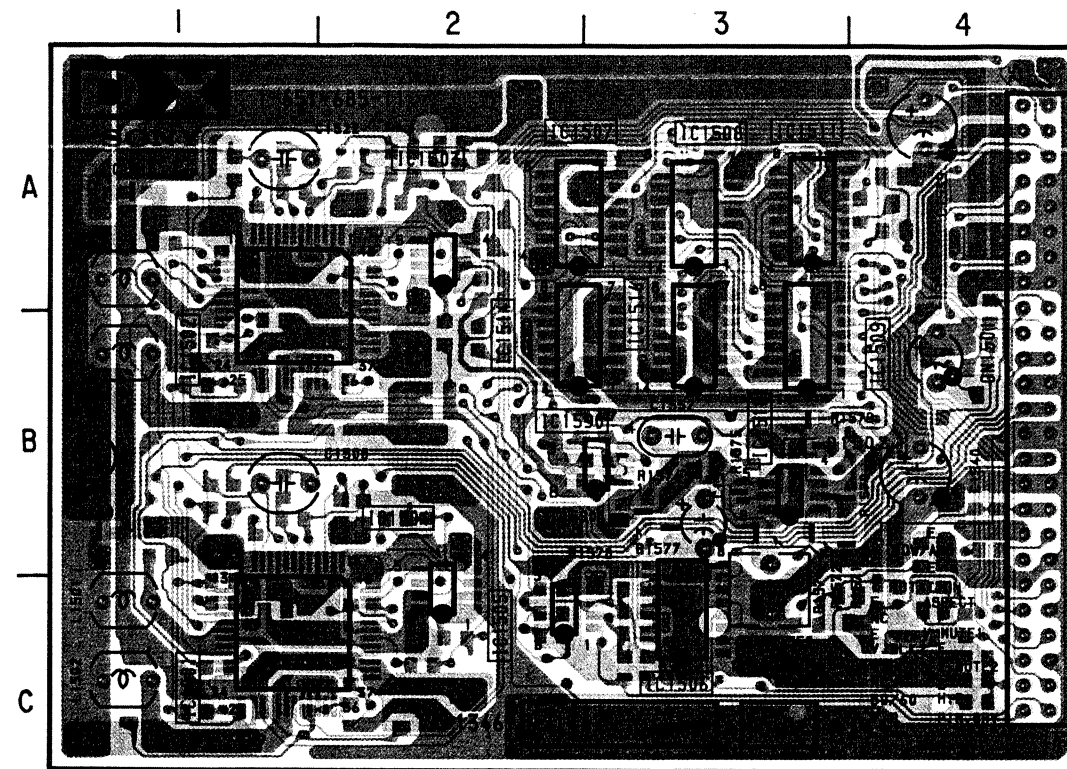

(Conductor Side)

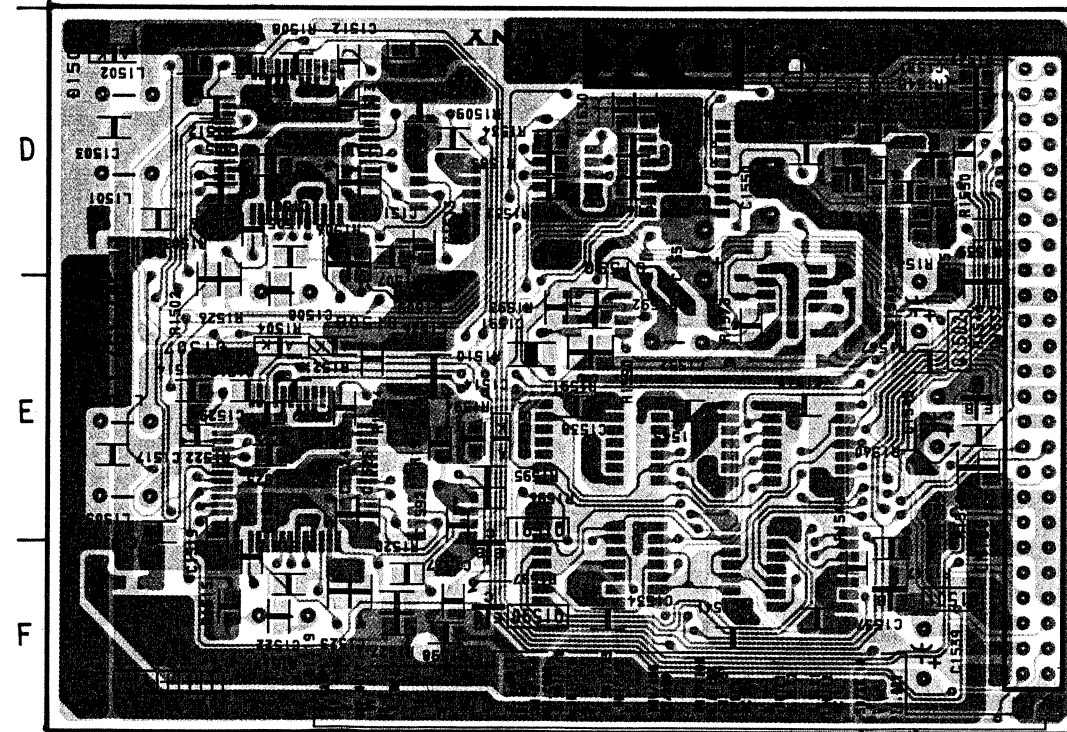

Note :

- [Pattern] : Pattern from the side which enables seeing.
- [Pattern] : Pattern of the rear side.

- M BOARD - (Component Side)

M BOARD

IC	
IIC801	A-2, E-2
C802	B-4
IC803	B-4
IC804	B-1
IC805	B-3
IC806	C-2
DIODE	
D801	A-4
D802	E-3
D803	A-4
D804	E-3
D805	D-1
D806	D-1
D807	D-1
D808	C-1
D809	C-3
D810	D-1
D811	D-3
D812	E-3
D813	D-3
D814	E-3

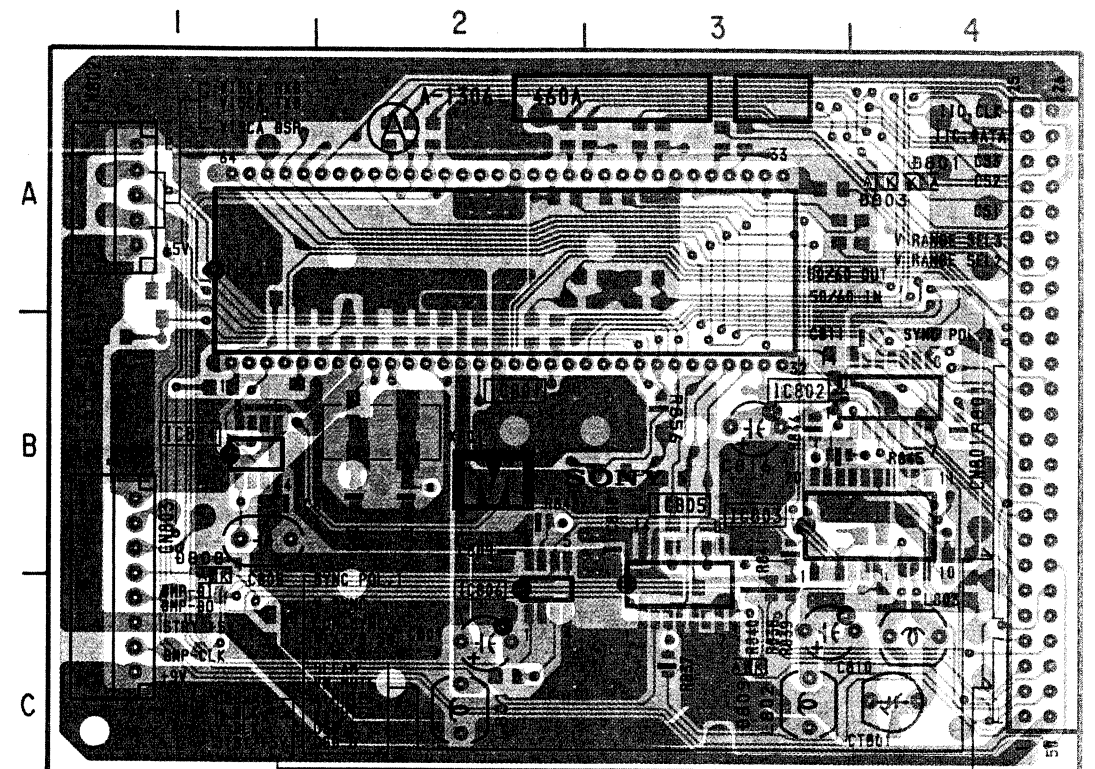

(Conductor Side)

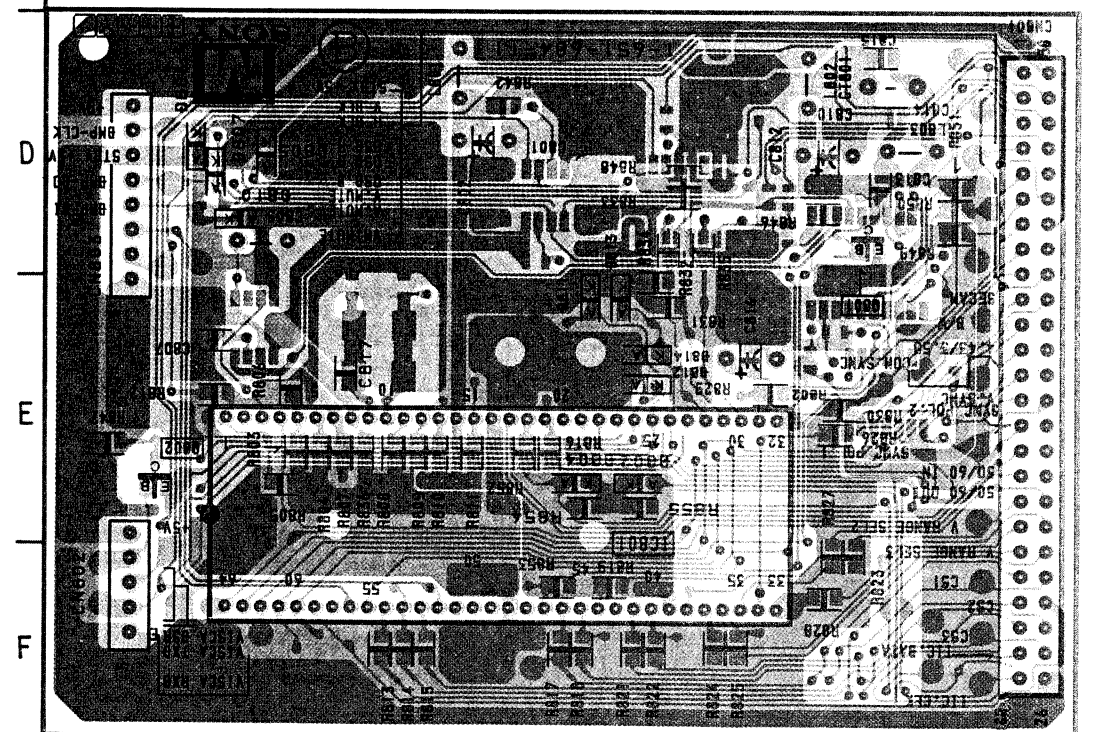

Note :

- [Pattern] : Pattern from the side which enables seeing.
- [Pattern] : Pattern of the rear side.

• DX BOARD WAVEFORMS

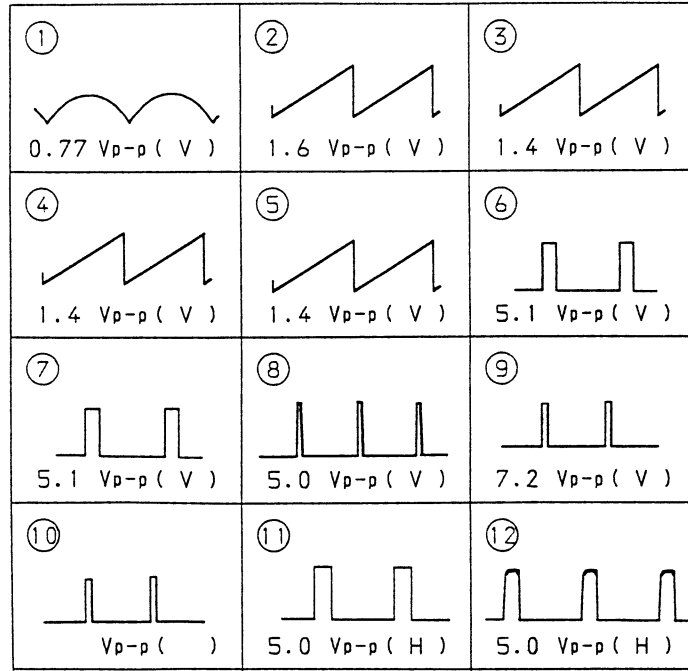

DX BOARD

D1501	H BLK SW 3
D1502	6.8V CLAMP
D1505	PROTECT
D1506	PROTECT
D1507	PROTECT
D1508	PROTECT
D1590	REF VOLT
D1591	VOLT RECT
IC1501	SERVICE GEO CTRL
IC1502	USER GEO CTRL
IC1503	V SAW BUFF
IC1504	V SAW BUFF
IC1505	SAW PARA OUT
IC1506	D/A CONV
IC1507	REF SHIFT 5
IC1508	REF SHIFT 6
IC1509	REF SHIFT 4
IC1511	REF SHIFT 3
IC1514	REF SHIFT 1
IC1516	REF SHIFT 2
IC1518	AFC CORR
IC1590	ABL BLK
Q1501	SHIFT SW
Q1502	ABL BUFF
Q1503	H BLK SW 1
Q1504	H BLK SW 2
Q1590	ABL BLK OUT 1
Q1591	ABL BLK OUT 2

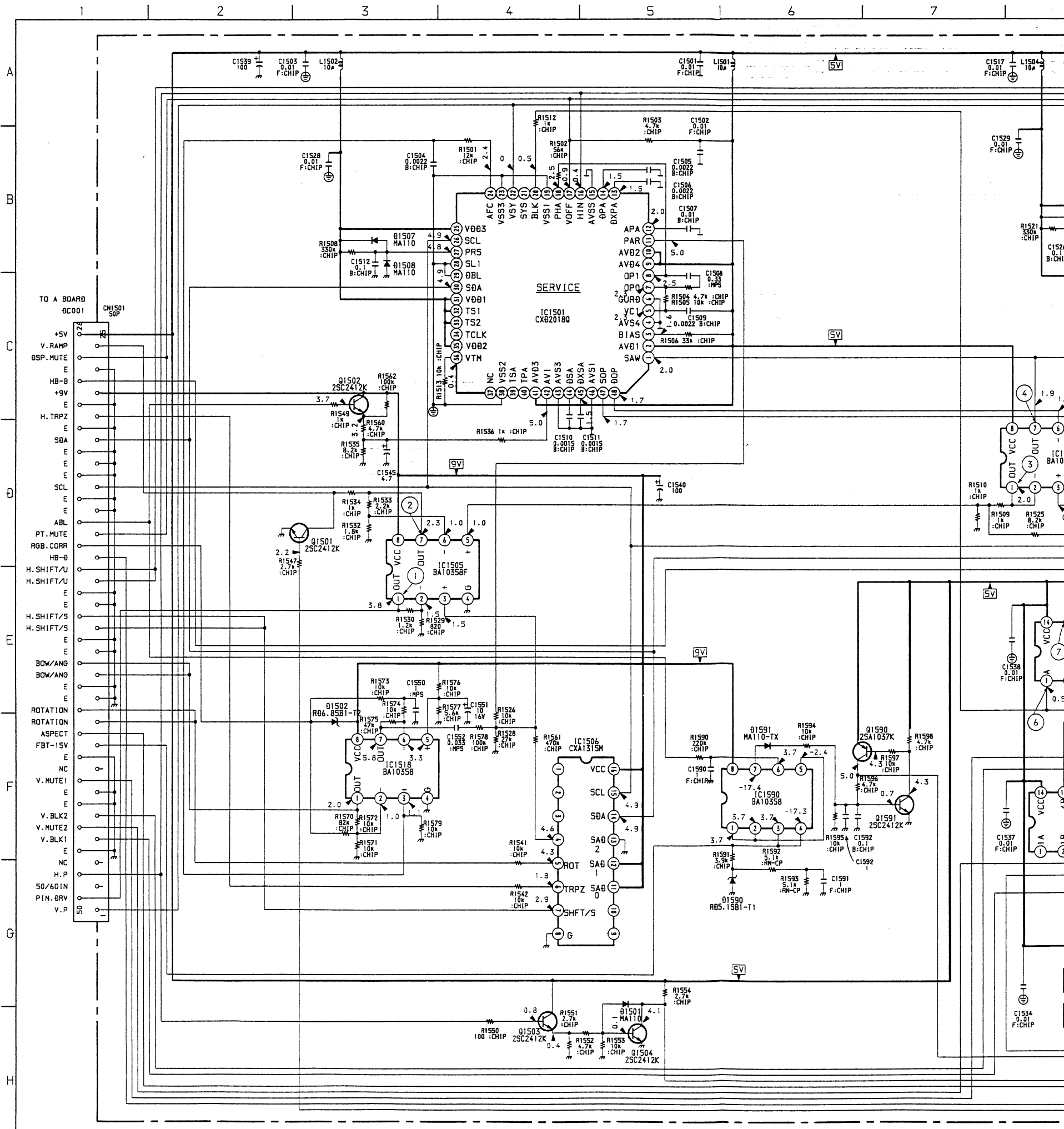
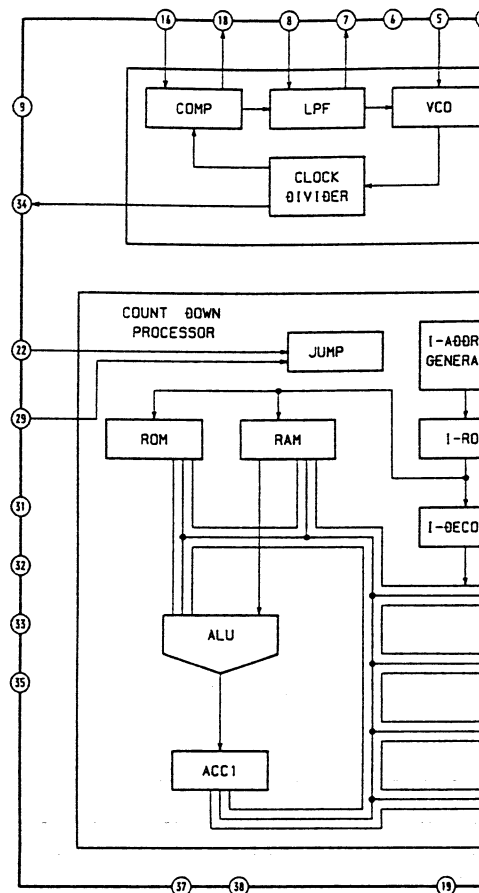

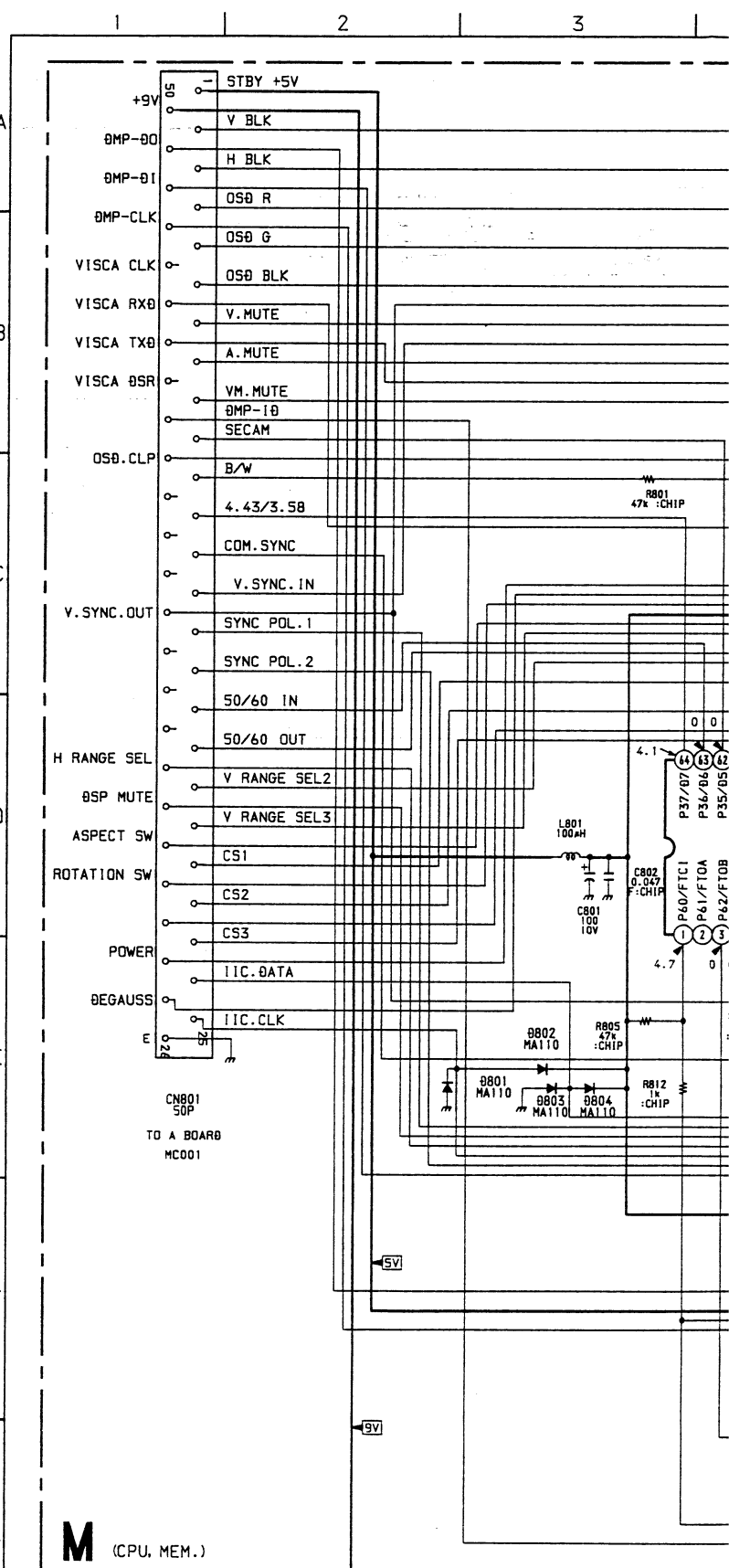
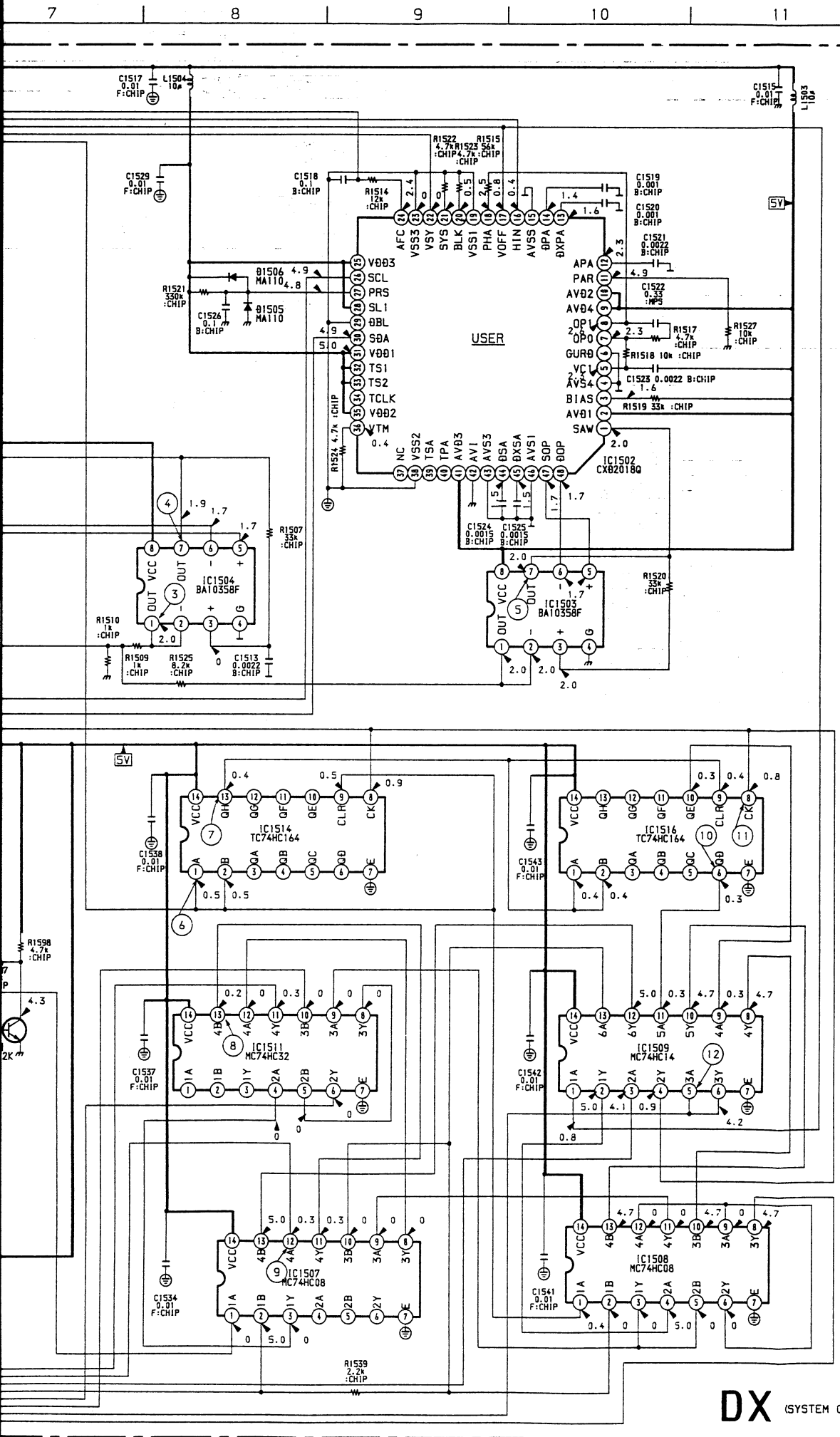
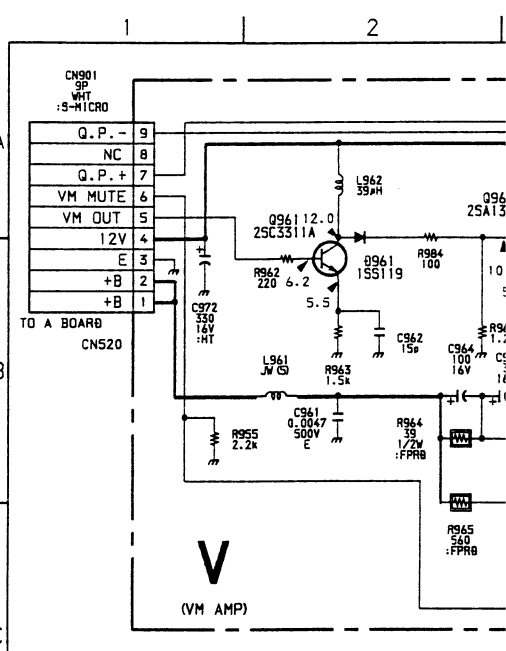
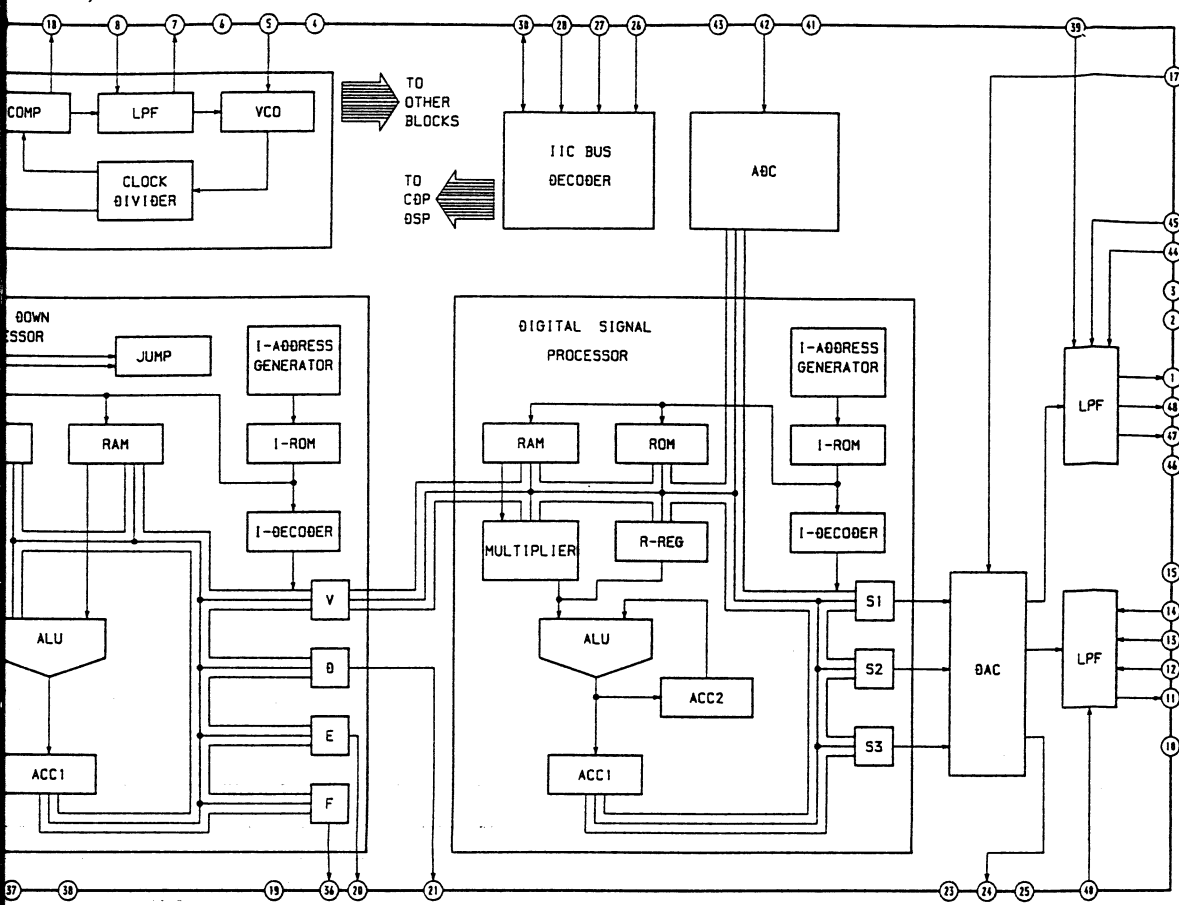

DX (SYSTEM CONT)

B-553218(L/C)-BX.

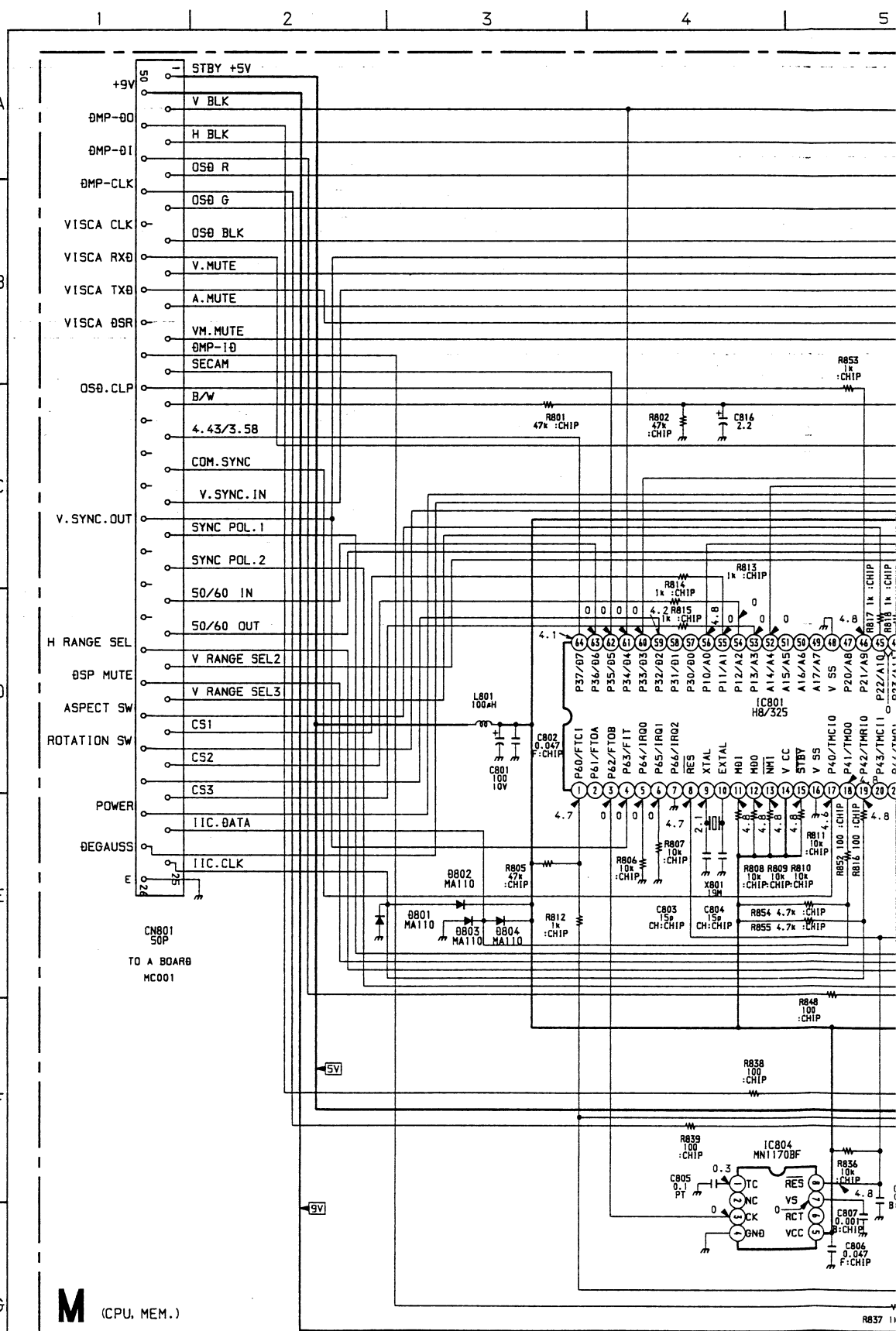
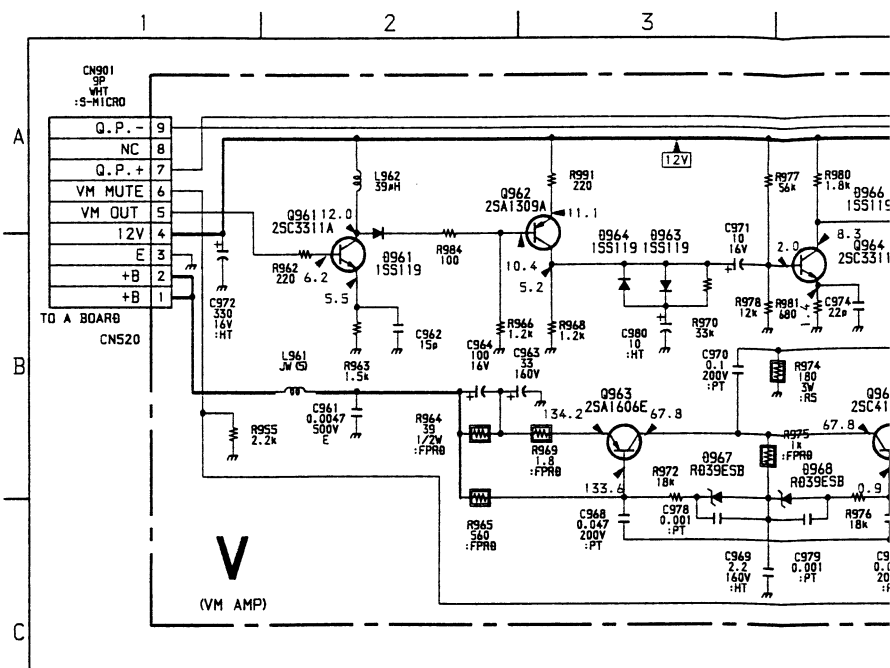
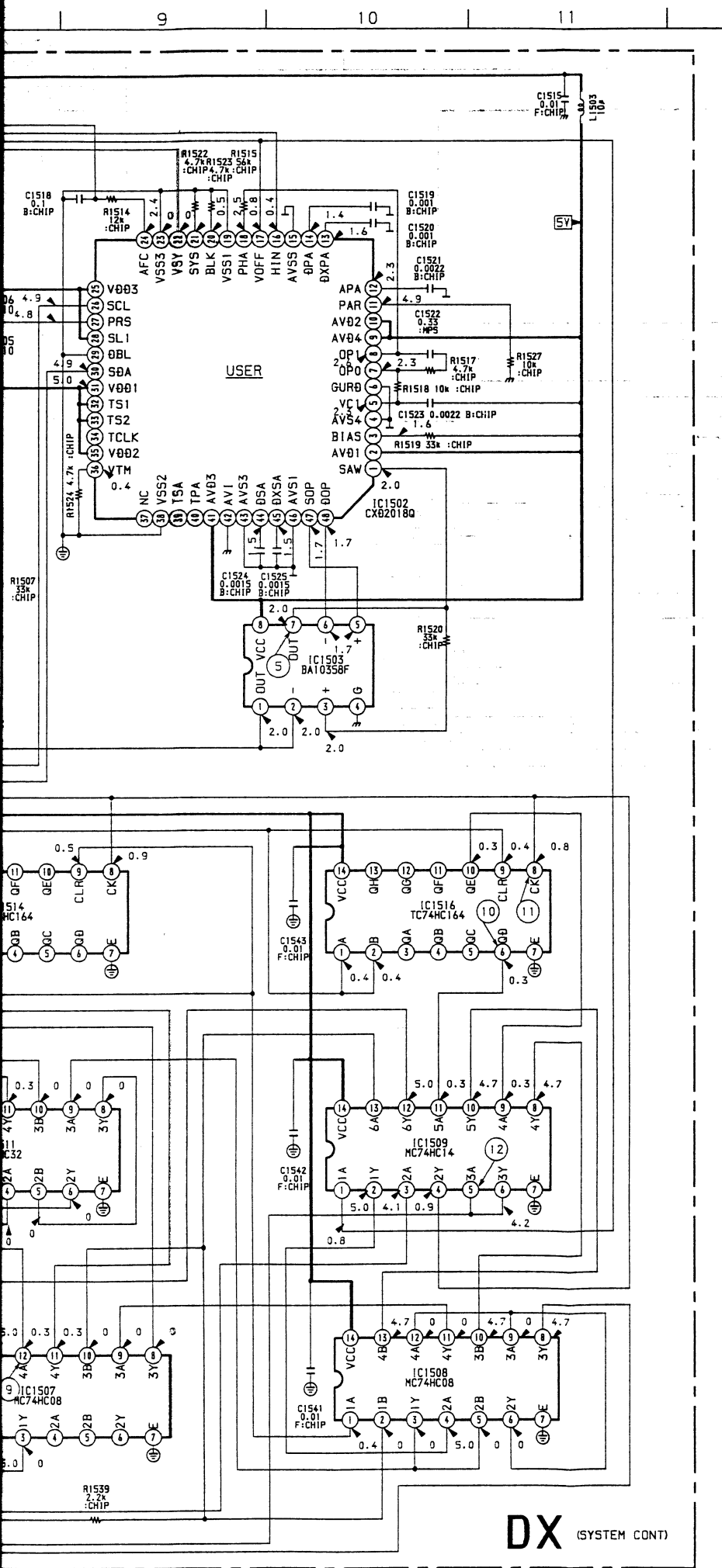
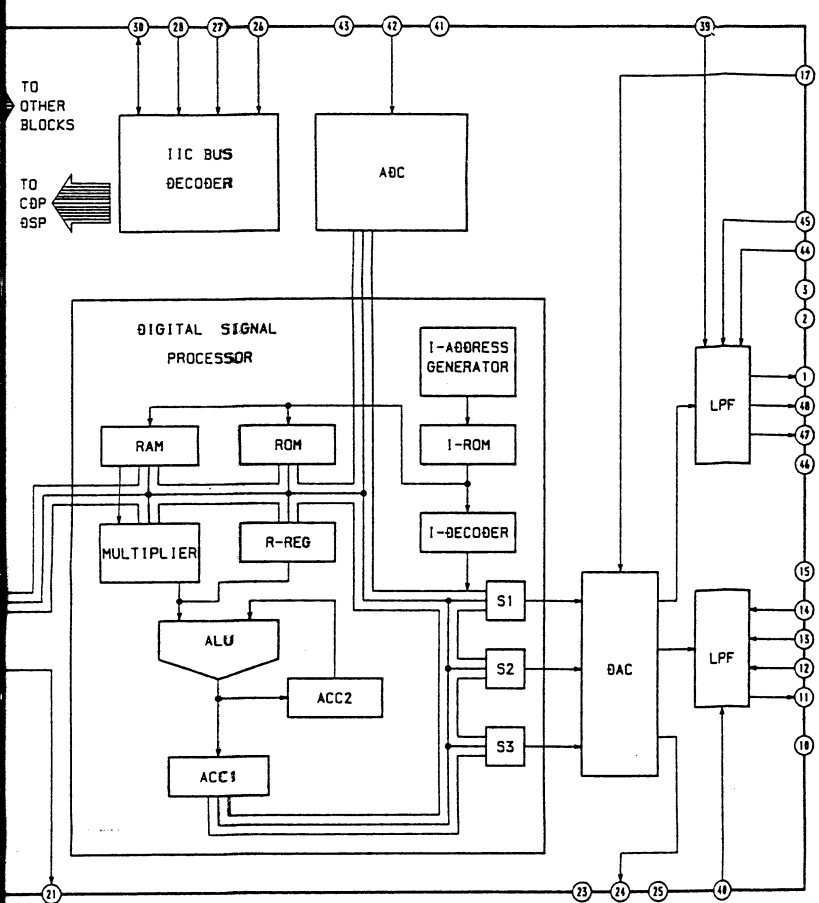

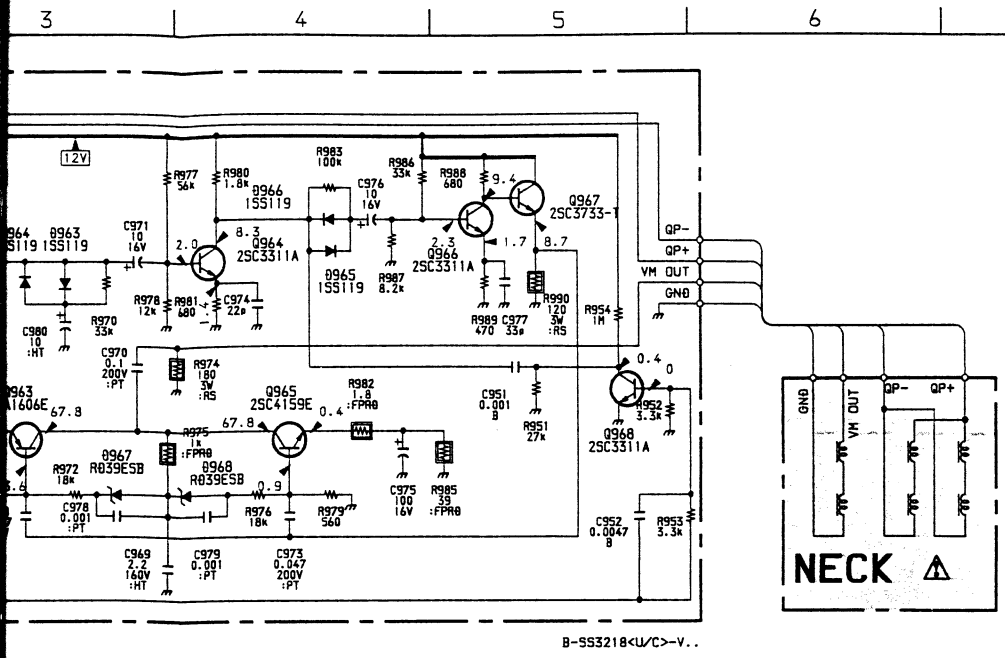

V BOARD

D961	DC BIAS
D963	SLI CE
D964	SLI CE
D965	CLIP
D966	CLIP
D967	PROT
D968	PROT
Q961	VM AMP 1
Q962	VM AMP 2
Q963	VM OUT
Q964	VM BUFF
Q965	VM OUT
Q966	VM OUT 1
Q967	VM OUT 2
Q968	MUTE SW

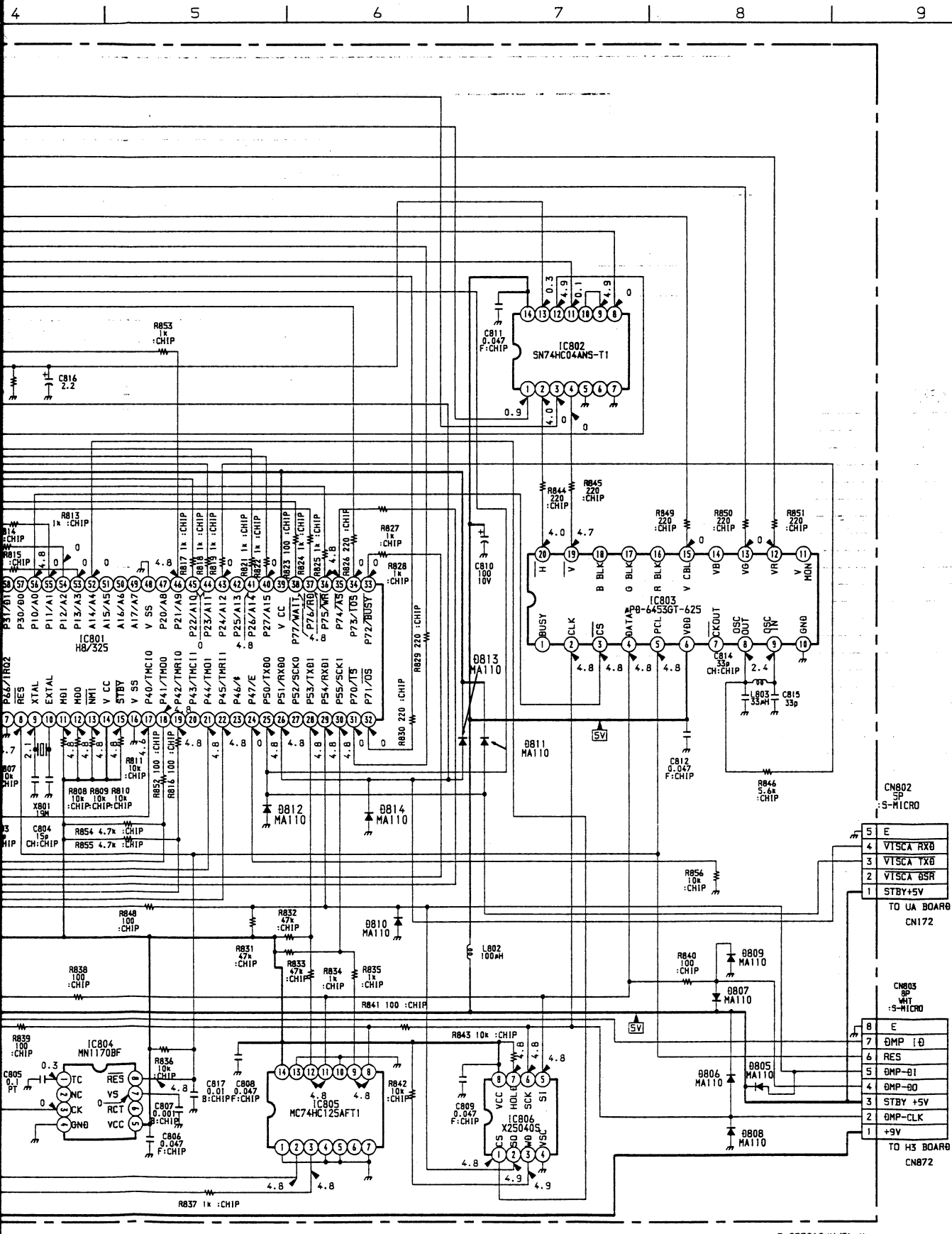

M BOARD

D801	PROTECT
D802	PROTECT
D803	PROTECT
D804	PROTECT
D805	PROTECT
D806	PROTECT
D807	PROTECT
D808	PROTECT
D809	PROTECT
D810	PROTECT
D811	PROTECT
D812	PROTECT
D813	PROTECT
D814	PROTECT
IC801	MICOM
IC802	INVERTER
IC803	CHARACTER GEN
IC804	RESET
IC805	BUFF
IC806	MEMORY

• UT BOARD WAVEFORMS

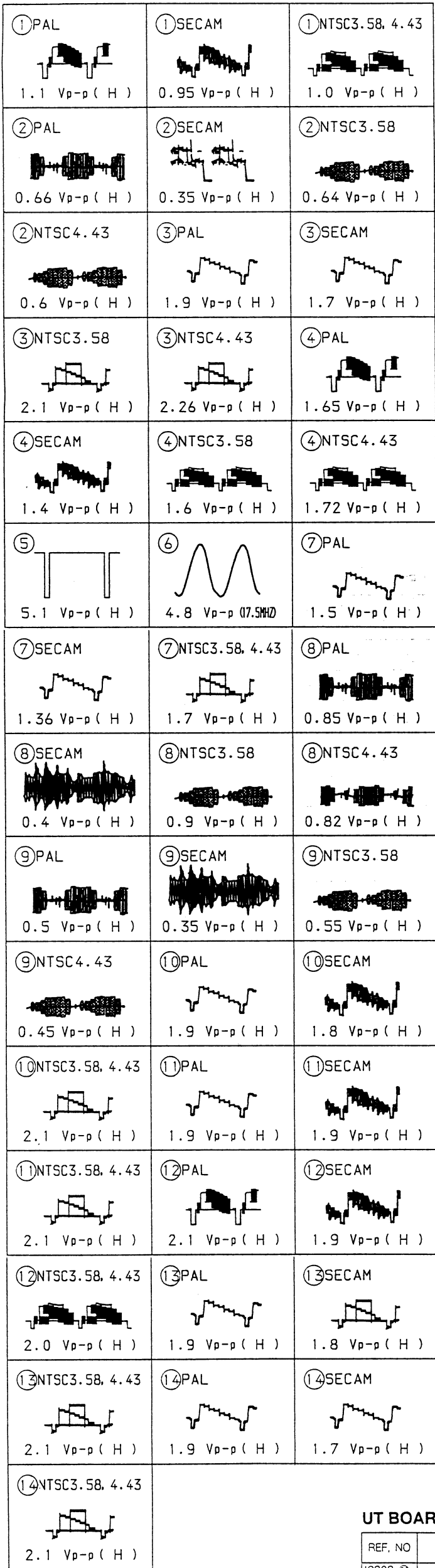

UT BOARD

D202	SECAM SW
D203	CLAMP
D205	CLAMP
D206	PROTECT
IC201	A/V SW
IC202	DIGITAL COMFILTER
IC203	Y SW
IC204	AUDIO CONT
IC205	SYSTEM CONT
IC206	V SW
IC207	C SW
IC208	Y SW
Q201	Y AMP
Q202	Y AMP
Q203	Y AMP
Q204	C OUT
Q205	Y OUT
Q206	V OUT
Q207	Y BUFF
Q208	V BUFF
Q211	C BUFF
Q212	SECAM SW 2
Q213	CLK AMP
Q214	CLK AMP
Q215	C AMP
Q216	SECAM SW 1
Q217	V BUFF 1
Q218	V BUFF 2
Q219	V BUFF 3
Q220	V BUFF 4
Q221	V BUFF 5
Q222	SECAM SW
Q223	Y AMP
Q224	Y AMP
Q225	Y AMP
Q226	Y AMP
Q227	Y BUFF
Q228	Y SW
Q229	Y SW
Q230	Y BUFF
Q231	Y AMP
Q232	Y BUFF

UT BOARD * MARK

REF. NO	PAL	SECAM	NTSC 358	NTSC 443
IC202 ㉔	4.0	4.1	0.1	4.1
IC203 ㉕	1.5	3.5	1.5	1.5
IC206 ㉖	5.0	5.0	5.0	2.3
IC208 ㉘	11.9	11.9	0	11.9
Q212 B	0	5.0	0	0
E	0	4.4	0	0
Q216 B	4.6	0	4.6	4.6
C	0	5.0	0	0
Q222 C	1.5	3.5	1.5	1.5
Q227 C	12.0	11.9	0	11.9

UT BOARD IC204 TA8184P

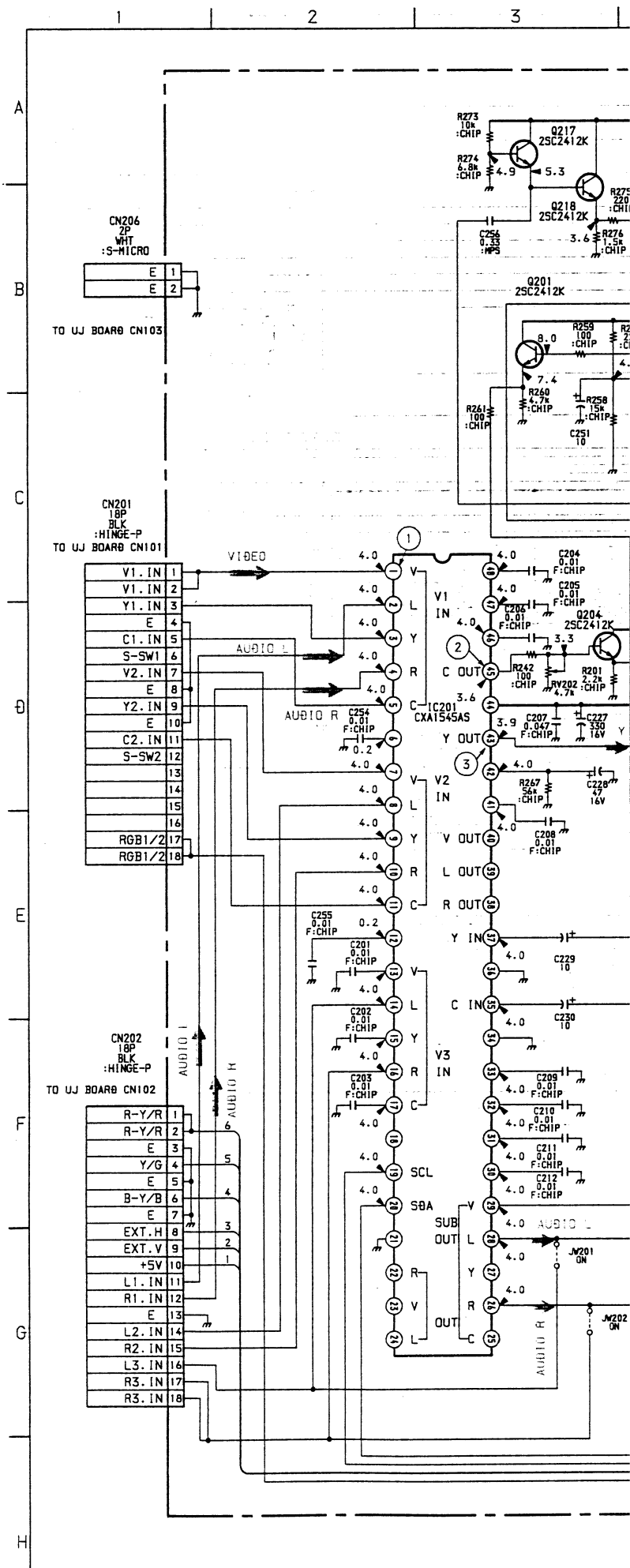
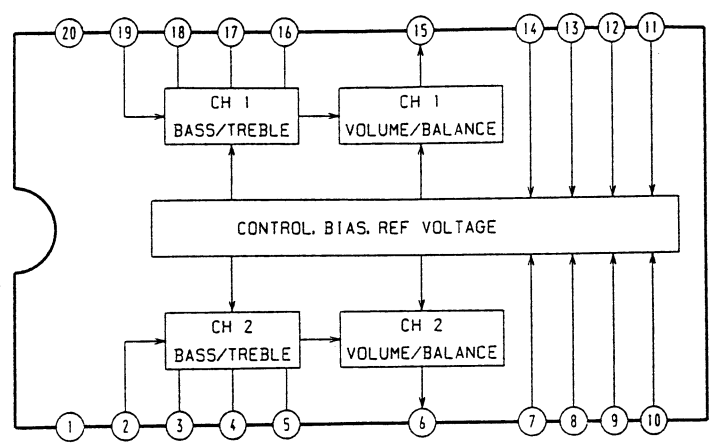

UT BOARD IC205 CXA1315M

UT BOARD IC201 CXA1545AS

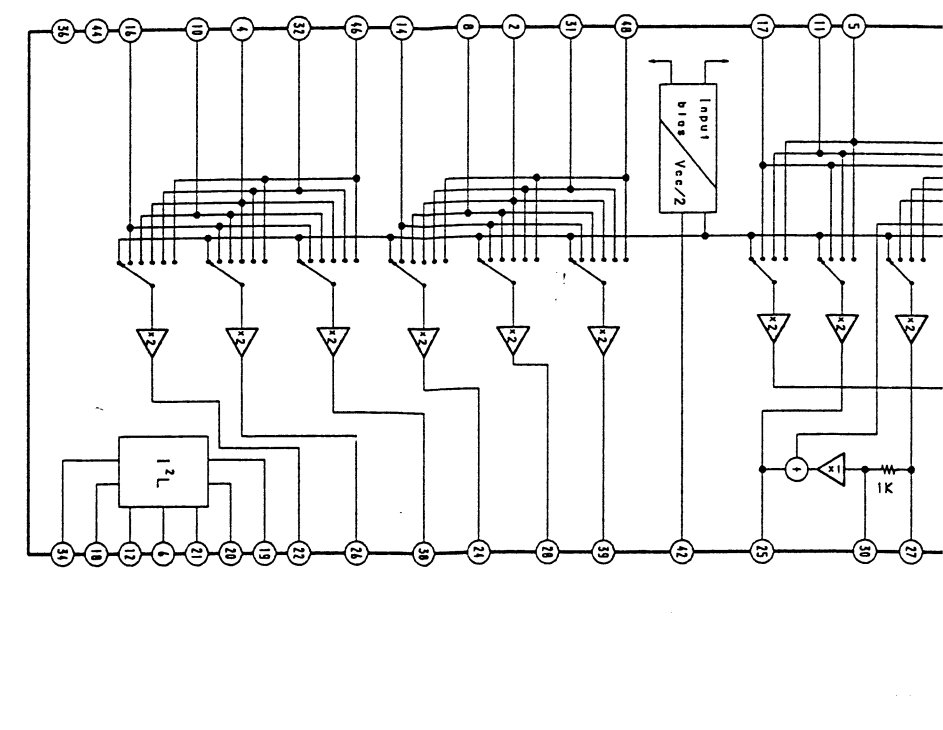
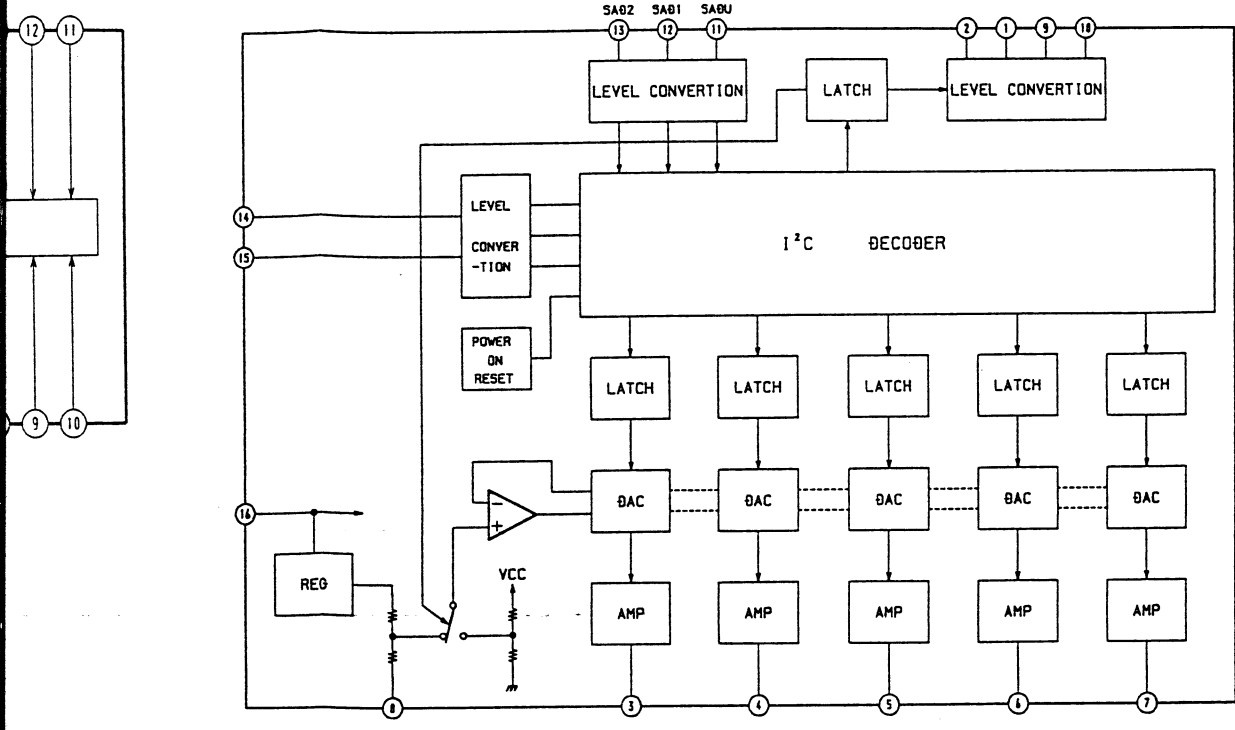

3

4

5

6

7

8

9

10

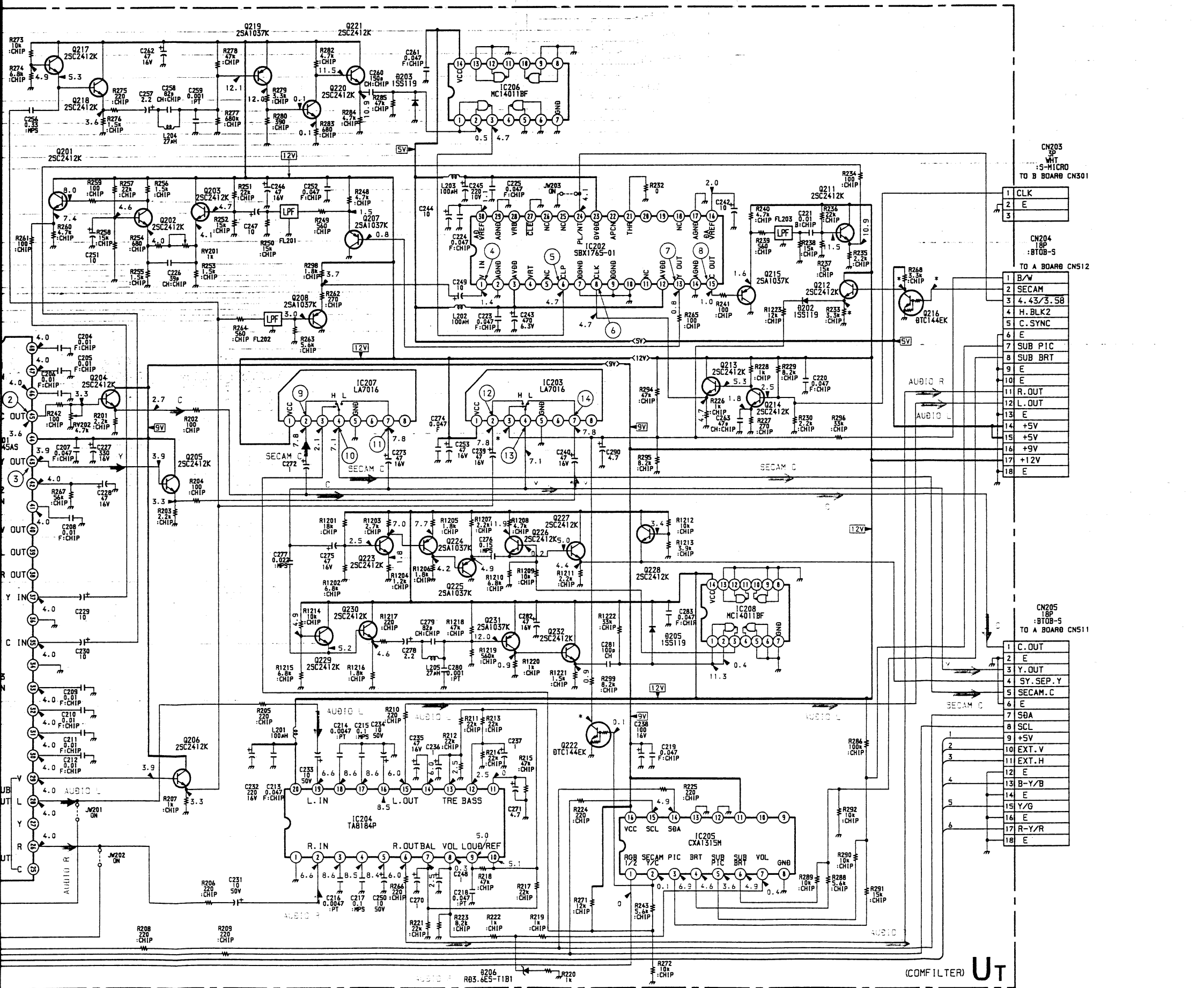

1	CLK
2	E
3	

1	B/W
2	SECAM
3	4.43/3.58
4	H. BLK2
5	C. SYNC
6	E
7	SUB PIC
8	SUB BRT
9	E
10	E
11	R. OUT
12	L. OUT
13	E
14	+5V
15	+5V
16	+5V
17	+12V
18	E

1	C. OUT
2	E
3	Y. OUT
4	SY. SEP. Y
5	SECAM. C
6	E
7	S0A
8	SCL
9	+5V
10	EXT. V
11	EXT. H
12	E
13	B-Y/B
14	E
15	Y/G
16	E
17	R-Y/R
18	E

(COMFILTER) **UT**

B-553218<U/C>-UT.

ARD IC205 CXA1315M

UT BOARD IC201 CXA1545AS

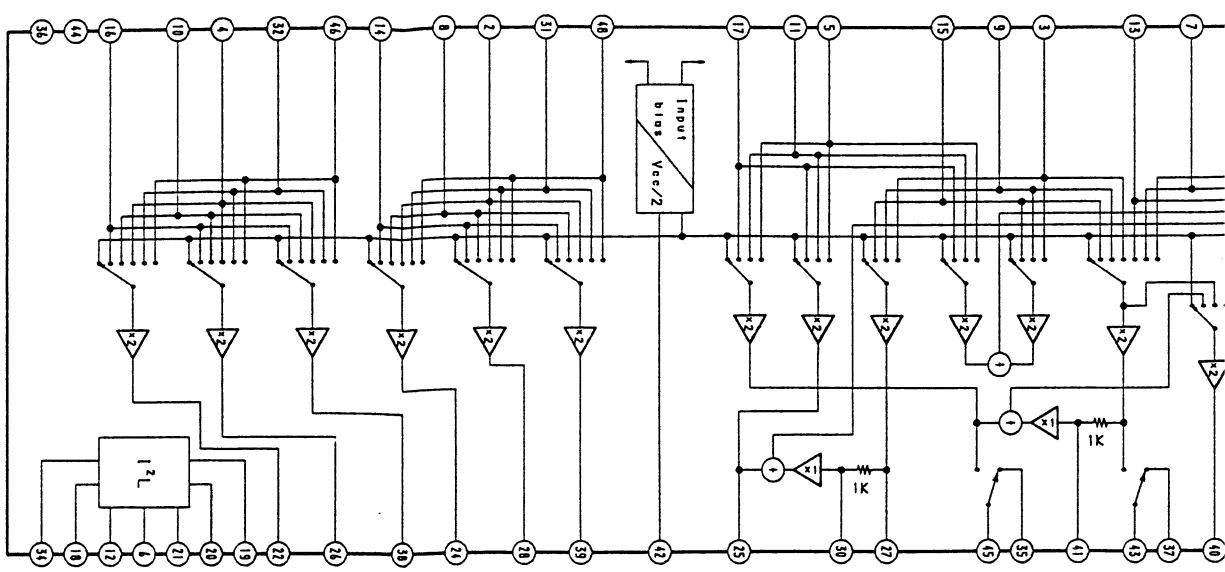
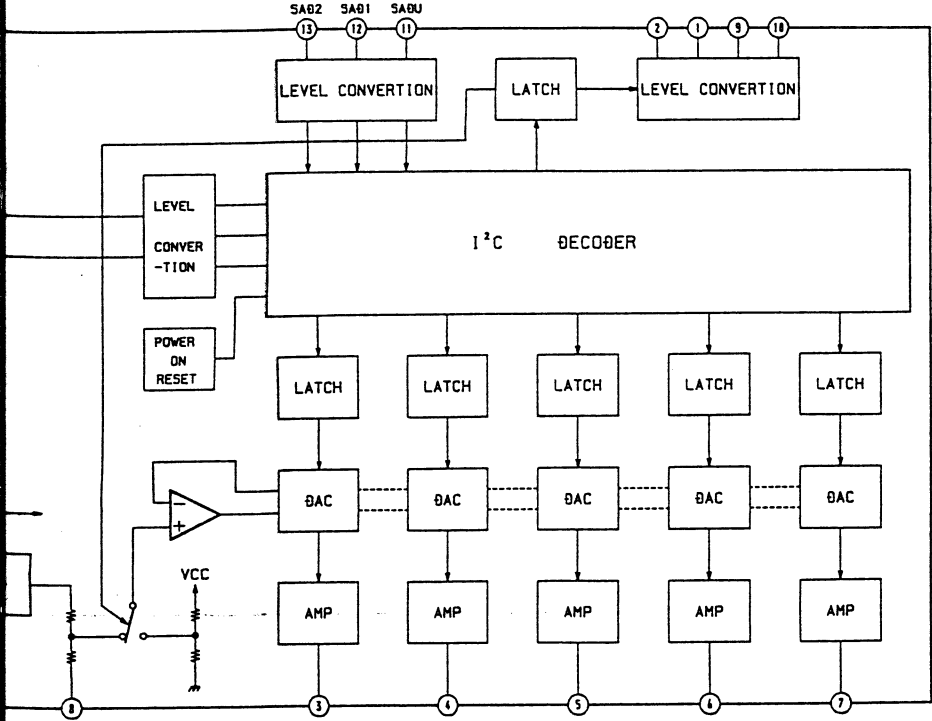

4 5 6 7 8 9 10

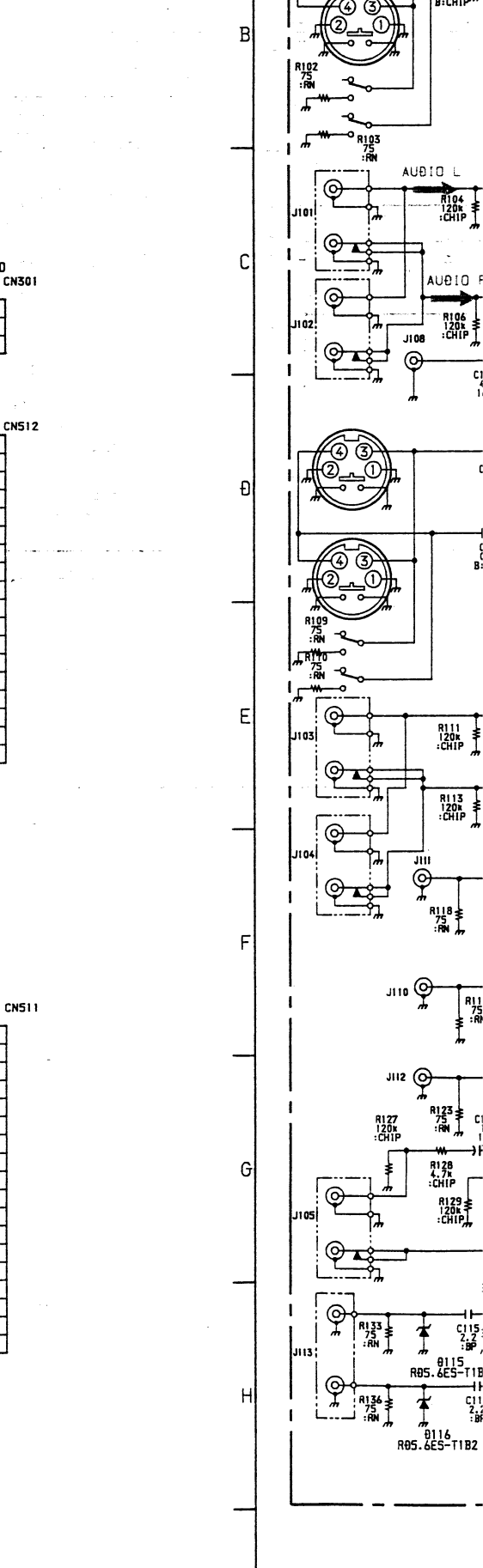
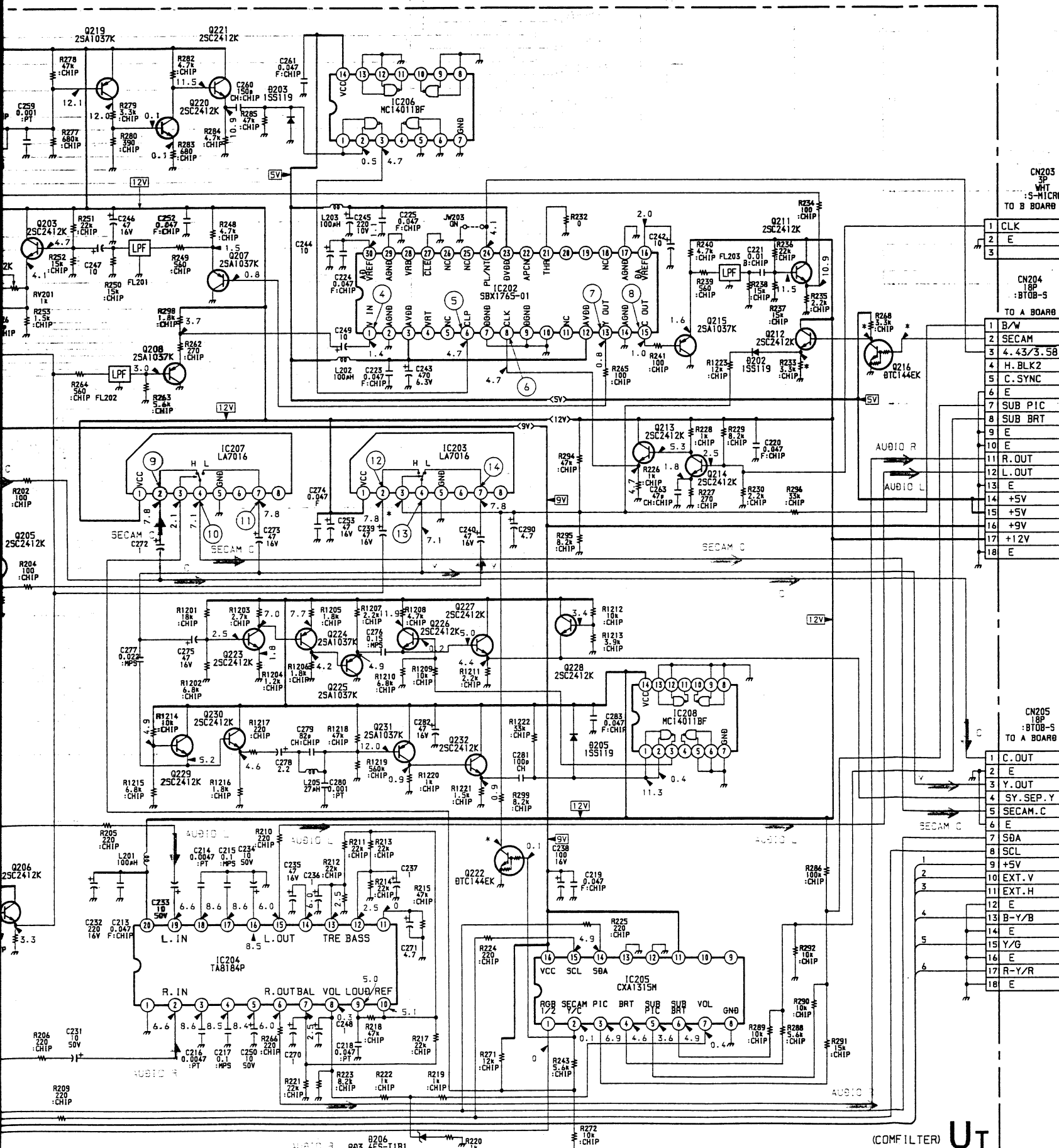

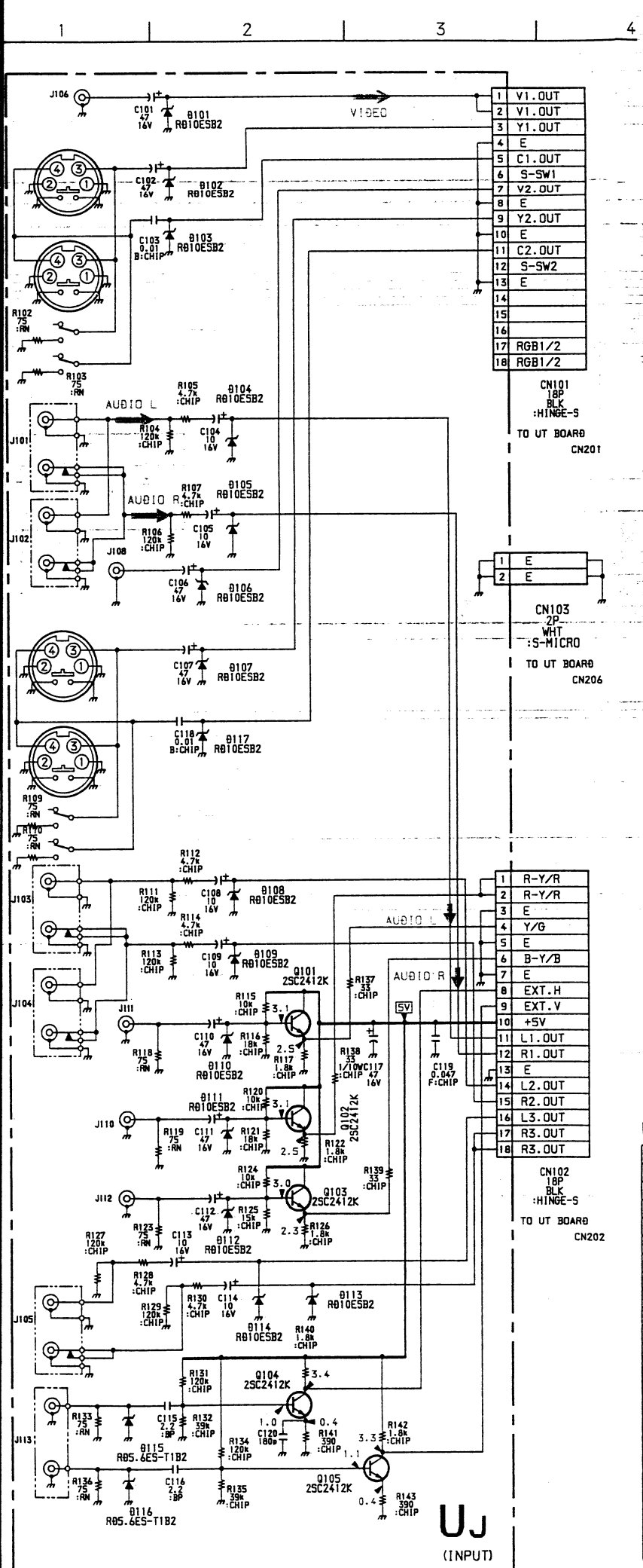
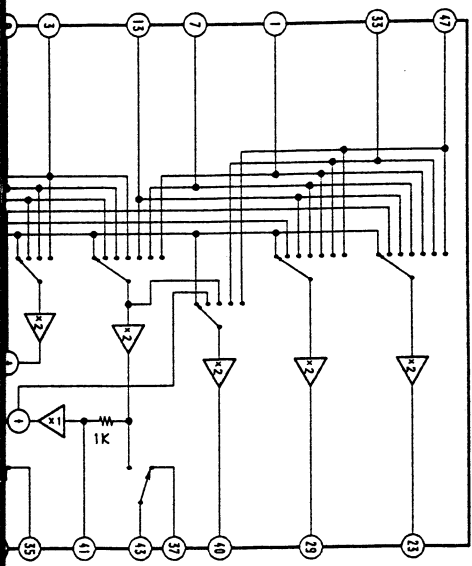

B-553218<U/C>-UJ.

UJ BOARD

D101	PROTECT
D102	PROTECT
D103	PROTECT
D104	PROTECT
D105	PROTECT
D106	PROTECT
D107	PROTECT
D108	PROTECT
D109	PROTECT
D110	PROTECT
D111	PROTECT
D112	PROTECT
D113	PROTECT
D114	PROTECT
D115	PROTECT
D116	PROTECT
D117	PROTECT
Q101	R-Y/R BUFF
Q102	R-Y/R BUFF
Q103	B-Y/B BUFF
Q104	SYNC BUFF
Q105	SYNC BUFF

UA BOARD

D171	PROTECT
D172	PROTECT
D173	PROTECT
D174	PROTECT
D175	PROTECT
D176	PROTECT
D177	PROTECT
IC171	VISCA DRIVER
Q171	SIRCS INVERT
Q172	SIRCS INVERT

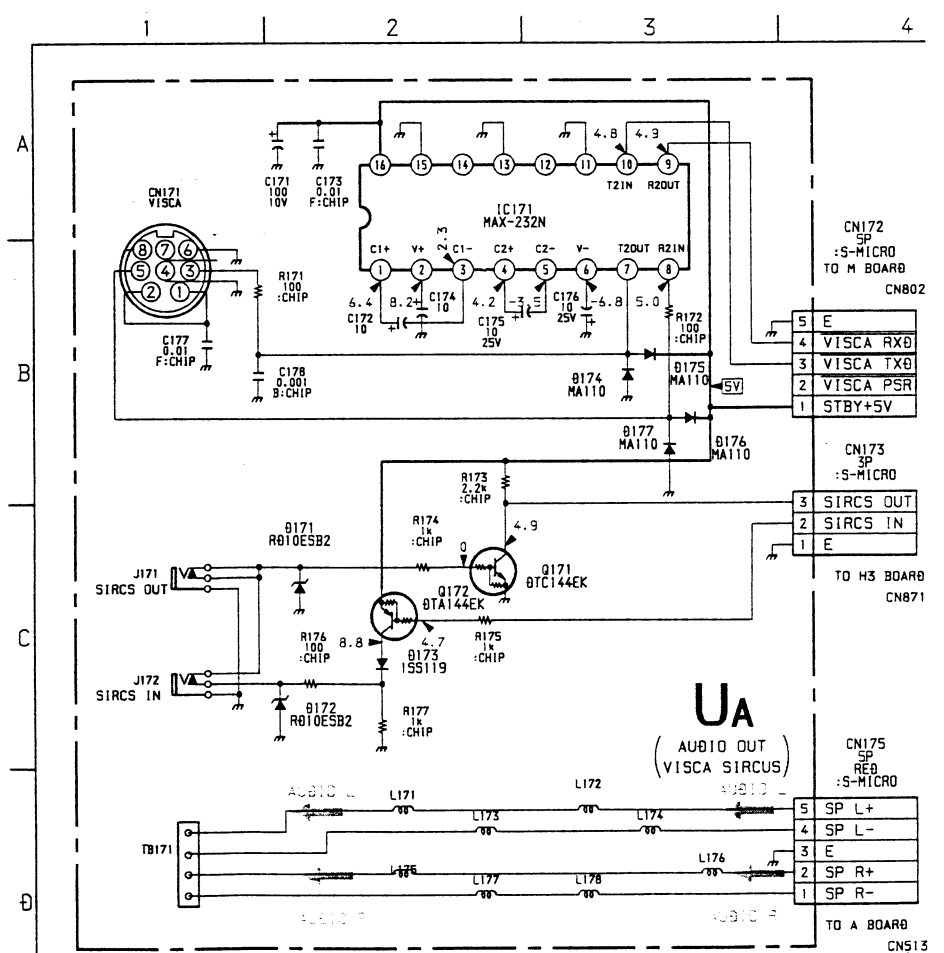

B-553218<U/C>-UA.

UT [COM FILTER] **UJ** [INPUT] **UA** [AUDIO OUT, VISCA, SIRCS]

- UTBOARD -

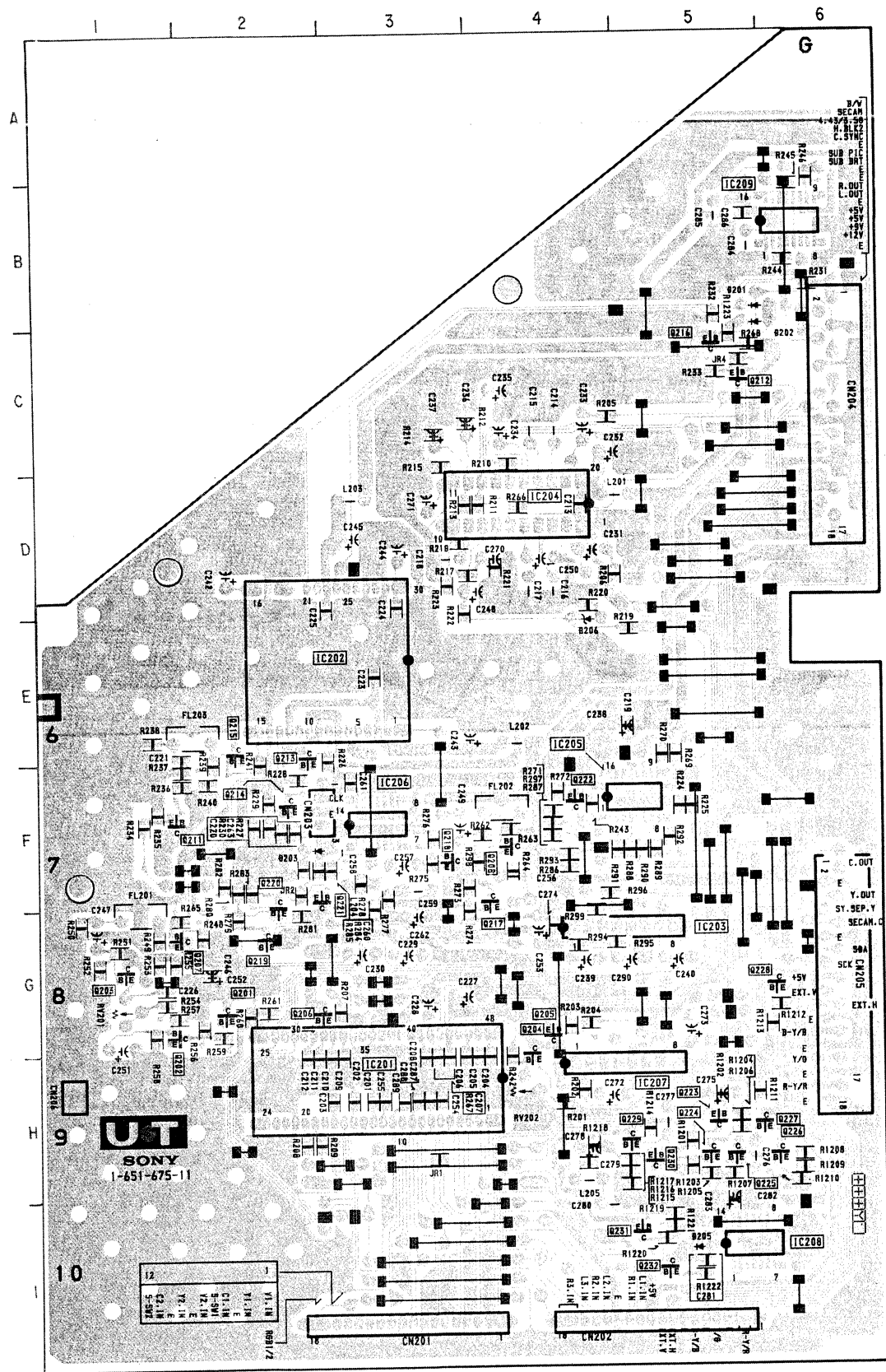

UT BOARD

IC	
IC201	H-3
IC202	E-2
IC203	G-5
IC204	D-4
IC205	F-5
IC206	F-3
IC207	H-5
IC208	I-5

DIODE	
D202	C-5
D203	F-2
D205	I-5
D206	E-4

TRANSISTOR

Q201	G-2
Q202	G-1
Q203	G-1
Q204	H-4
Q205	G-4
Q206	G-2
Q207	G-1
Q208	F-4
Q211	F-1
Q212	C-5
Q213	E-2
Q214	F-2
Q215	E-2
Q216	C-5
Q217	F-4
Q218	F-3
Q219	G-2
Q220	F-2
Q221	F-2
Q222	F-4
Q223	H-5
Q224	H-5
Q225	H-5
Q226	H-6
Q227	H-5
Q228	G-5
Q229	H-5
Q230	H-5
Q231	I-5
Q232	I-5

VARIABLE RESISTOR	
RV201	G-1
RV202	H-4

- UJ BOARD -

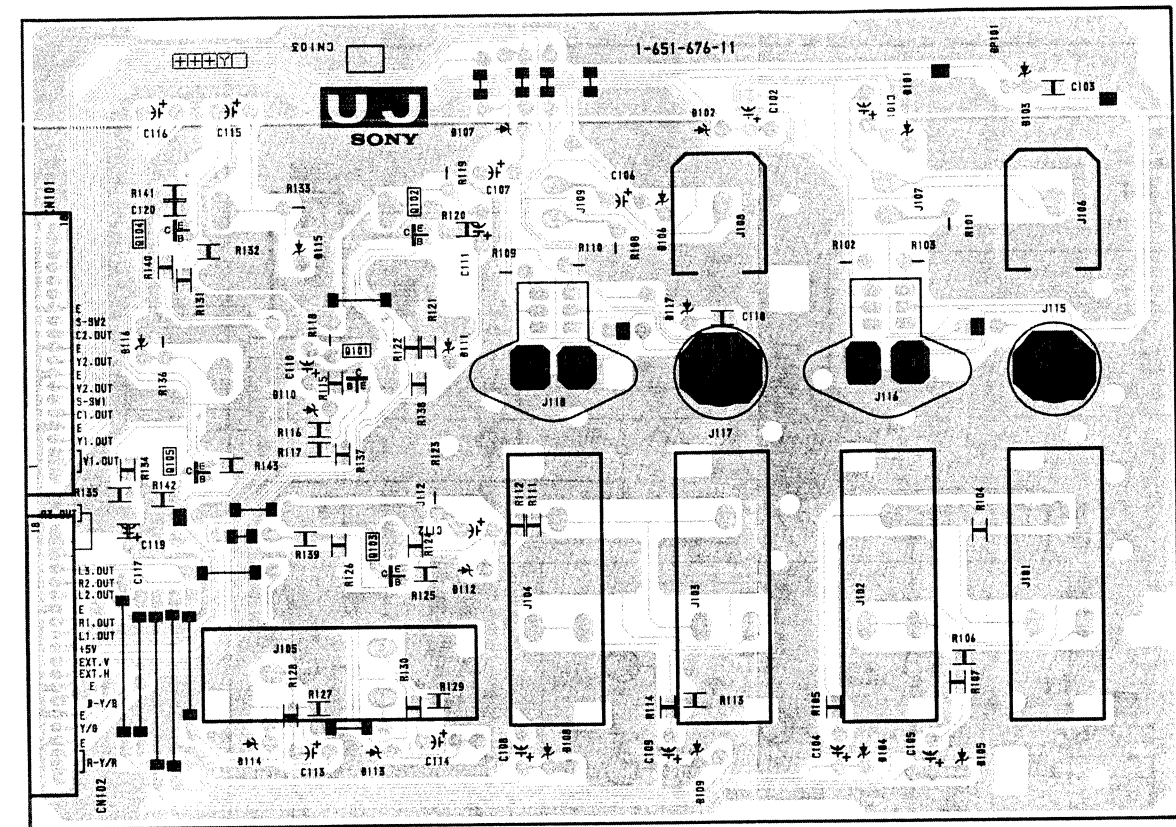

- UA BOARD

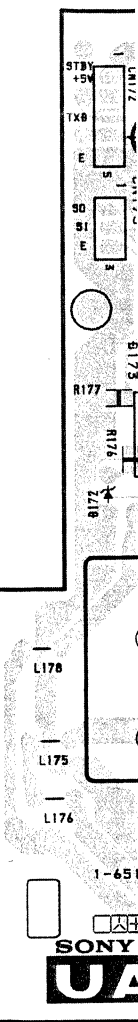

- UJ BOARD -

UT BOARD

IC	
IC201	H-3
IC202	E-2
IC203	G-5
IC204	D-4
IC205	F-5
IC206	F-3
IC207	H-5
IC208	I-5
DIODE	
D202	C-5
D203	F-2
D205	I-5
D206	E-4
TRANSISTOR	
Q201	G-2
Q202	G-1
Q203	G-1
Q204	H-4
Q205	G-4
Q206	G-2
Q207	G-1
Q208	F-4
Q211	F-1
Q212	C-5
Q213	E-2
Q214	F-2
Q215	E-2
Q216	C-5
Q217	F-4
Q218	F-3
Q219	G-2
Q220	F-2
Q221	F-2
Q222	F-4
Q223	H-5
Q224	H-5
Q225	H-5
Q226	H-6
Q227	H-5
Q228	G-5
Q229	H-5
Q230	H-5
Q231	I-5
Q232	I-5
VARIABLE RESISTOR	
RV201	G-1
RV202	H-4

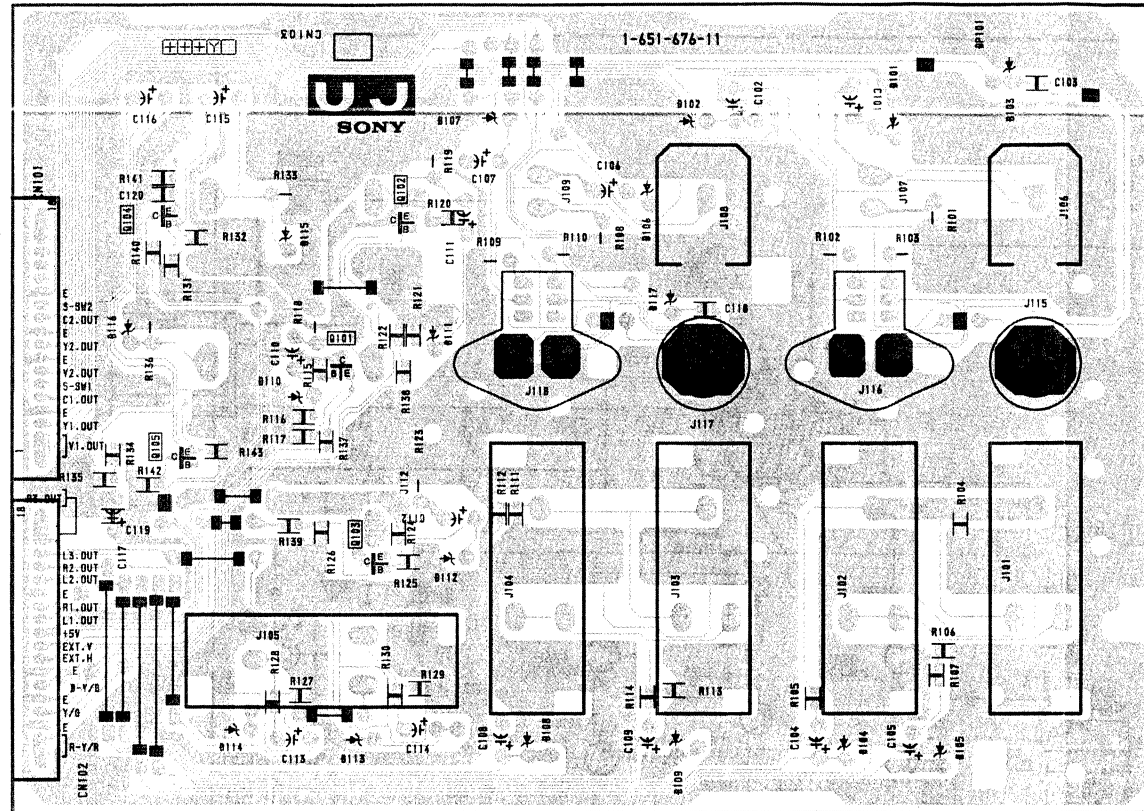

- UA BOARD -

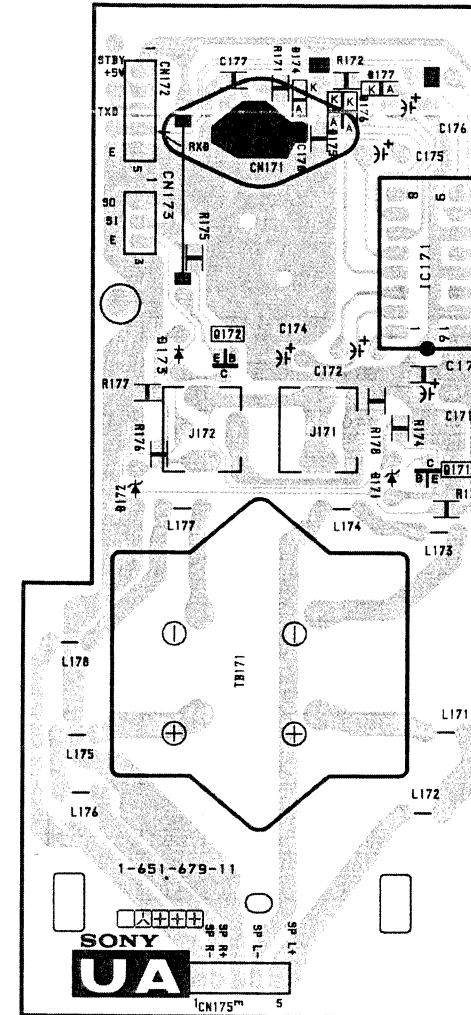

Schematic diagrams

board →

C BOARD

D704	PROTECT
D705	PROTECT
D706	PROTECT
D761	SPEED UP
D762	SPEED UP
D763	SPEED UP
D771	PROTECT
D772	PROTECT
D781	PROTECT
D782	PROTECT
D783	PROTECT
D784	BLK BUFF
IC701	3200 SW
Q701	R DRIVE
Q702	G DRIVE
Q703	B DRIVE
Q704	R OUT
Q705	G OUT
Q706	B OUT
Q761	IK DET
Q762	IK DET
Q763	IK DET
Q771	INVERT
Q772	BLK SW
Q773	IK BUFF
Q781	IK DET
Q782	IK DET
Q783	IK DET
Q784	BLK BUFF
Q790	B BUFF

C BOARD * MARK

REF. NO	PAL	SECAM	NTSC 3.58	NTSC 4.43
J701 KB	165.8	166.9	164.9	163.7
RG	154.6	156.6	155.3	154.8
KR	143.7	144.6	145.6	146.2
Q704 C	145.2	146.5	147.2	147.3
Q705 C	158.4	160.7	159.1	158.3
Q706 C	168.1	169.2	166.6	165.6
Q761 B	145.1	146.2	147.3	147.3
C	129.2	133.0	129.8	128.8
E	143.0	144.0	145.1	145.5
Q762 B	158.3	160.5	159.3	158.5
C	140.8	143.4	139.6	139.4
E	154.3	156.4	155.2	154.6
Q763 B	168.0	169.2	166.9	165.7
C	153.6	154.6	149.3	148.6
E	165.6	166.9	164.7	163.5
Q771 C	182.0	182.2	179.0	179.8
Q781 B	181.5	181.5	178.9	178.9
E	169.9	172.0	167.8	172.4
Q783 B	181.4	181.5	178.9	179.0
E	169.7	171.0	167.3	168.2
Q784 B	182.1	182.2	179.5	179.6
C	197.7	197.8	197.2	197.3
E	183.2	183.4	180.6	180.7

. C BOARD WAVEFORMS

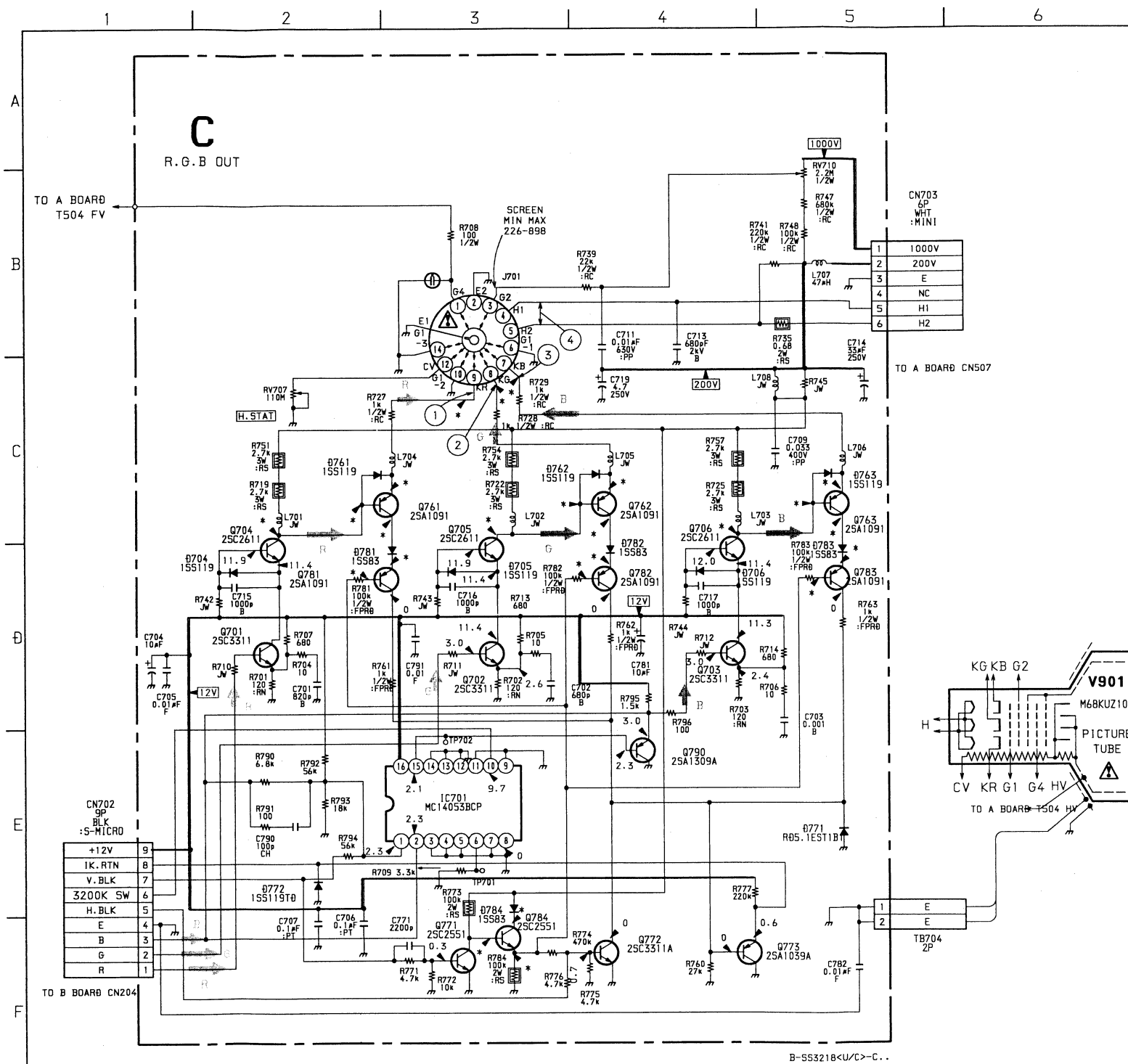
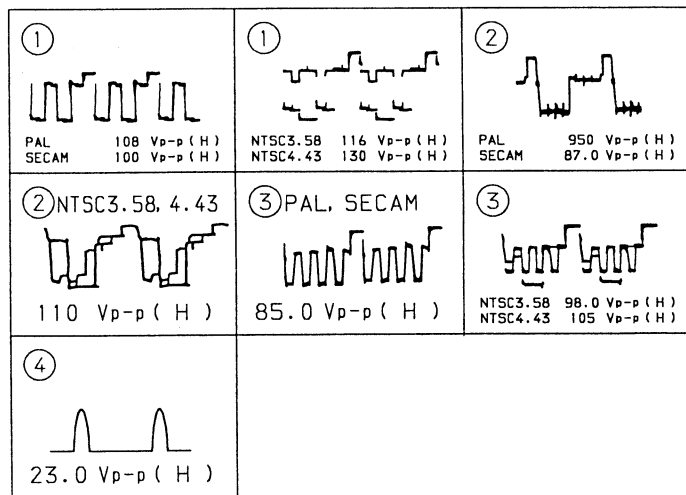

C [R. G. B OUT]

- C BOARD -

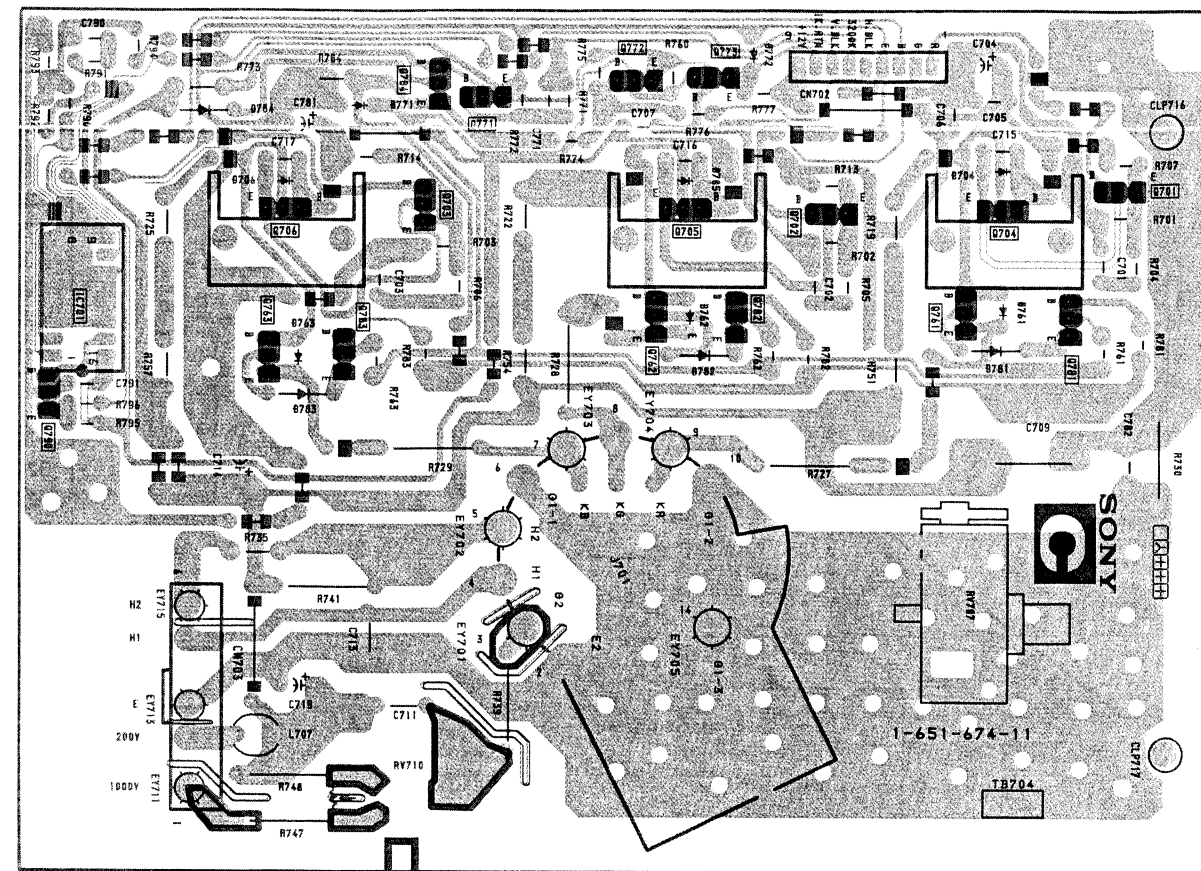
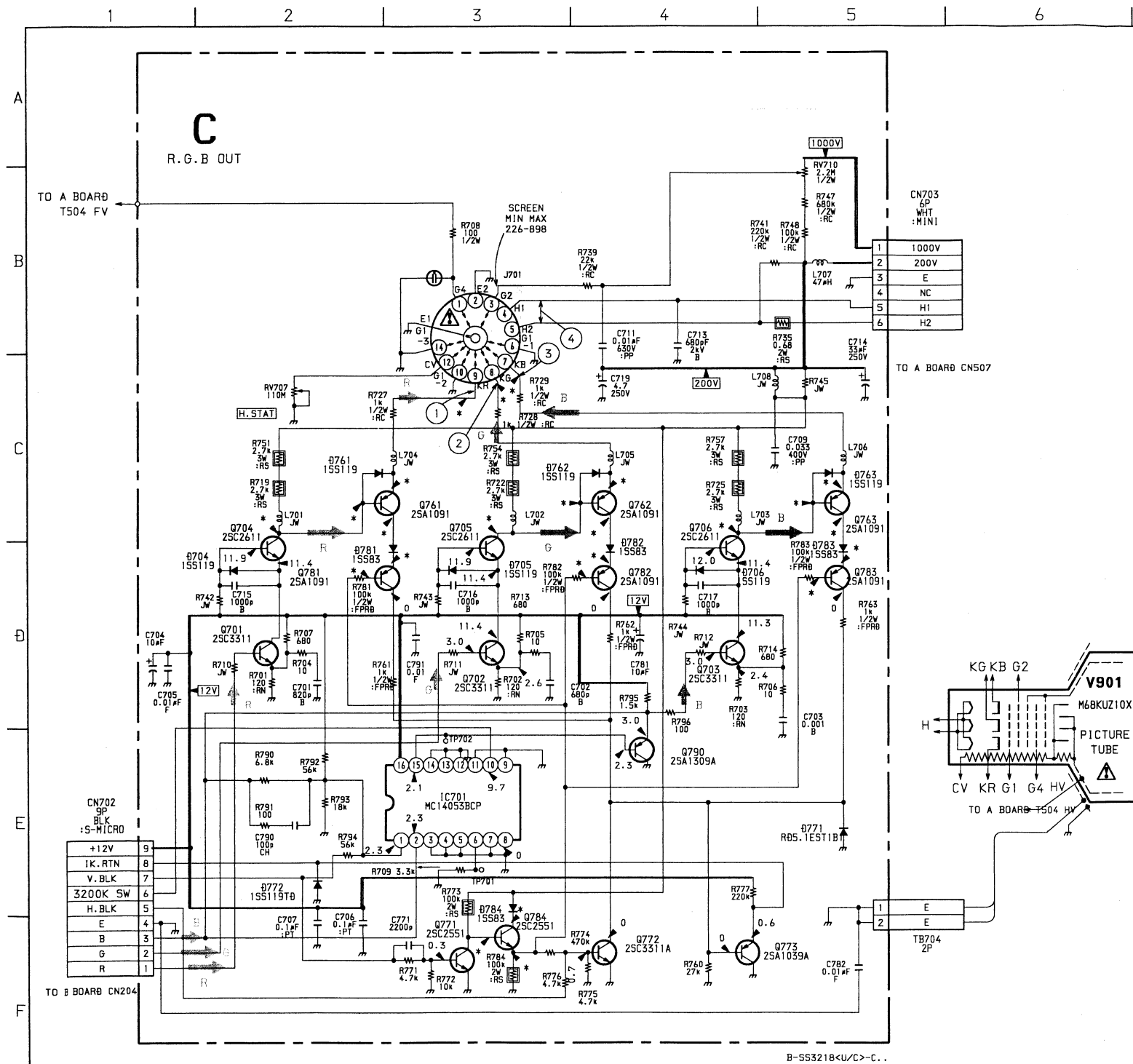

7-5. SEMICONDUCTORS

BA10358F
X250405I

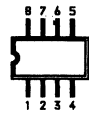

(TOP VIEW)

BA10358
BA10393
LM358N
LM358P
LM393P
MM1170BFB
MS216P
μPC353C
μPC393C

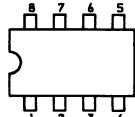

(TOP VIEW)

CXA1214P

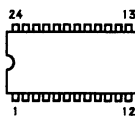

(TOP VIEW)

CXA1315M
MC14053BFP
MC74HC08AF-T2

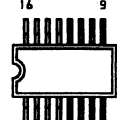

(TOP VIEW)

CXA1526P
LA7220
MAX232N
MC14053BCP
SN74LS221N
μP04053BC

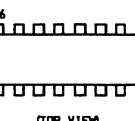

(TOP VIEW)

CXA1545AS
CXA1739S

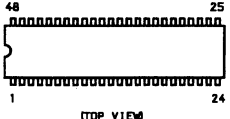

(TOP VIEW)

CX02018Q

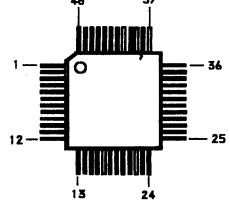

LA7016

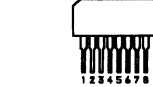

(TOP VIEW)

LA7851MK
LA7856

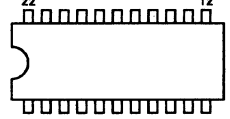

(TOP VIEW)

MC14011BF-T2
MC14070BF
MC74HC125AF
MC74HC14AF-T2
MC74HC32AF
SN74HC04ANS
SN74HC14ANS

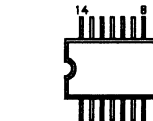

(TOP VIEW)

MC14052BF

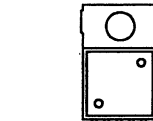

(TOP VIEW)

M51279SP

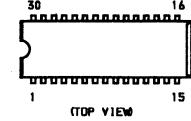

(TOP VIEW)

PM-21



MARKING SIDE VIEW

PM-30



MARKING SIDE VIEW

SC402130B

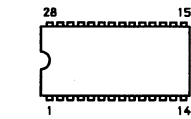

(TOP VIEW)

SBX1765-01

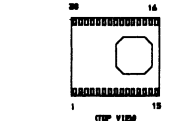

(TOP VIEW)

M52036SP
TA8184P

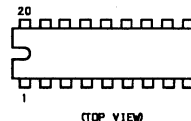

(TOP VIEW)

NJM78M05FA
TA7805S
TA7812S
μPC7805H
μPC7812H
XRA178M05T



(TOP VIEW)

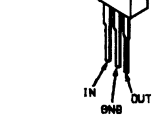

(TOP VIEW)

SE-135N

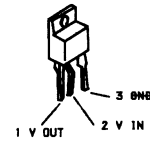

(TOP VIEW)

SI-3090CA

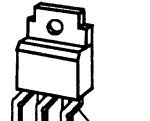

(TOP VIEW)

STR-M6515A

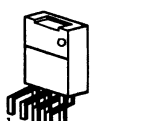

(TOP VIEW)

STV9379

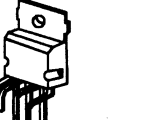

(TOP VIEW)

TAB200AH
TAB216H

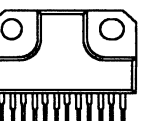

(TOP VIEW)

TC74HC164AF (EL)

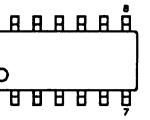

(TOP VIEW)

μPC645GT-625-E1

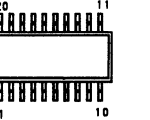

(TOP VIEW)

0TA114EK
0TA144EK
0TDC144EK
2SA1036K-R
2SA1037-QR
2SA1162G
2SC1623-L5L6
2SC2412K-QR

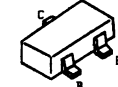

0TDC144ES

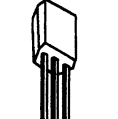

IRF614
2SA1606-E
2SB858-C
2SB860
2SC3298B-0
2SC4159-E
2SB1137
2SB2012
2SB2061-E, F

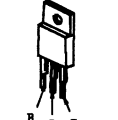

2SA1091-0
2SC2551-0

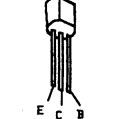

2SA1175-HFE
2SA1309A
2SC2785-HFE
2SC3311A

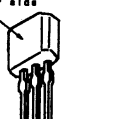

Letter side

2SB733-34
2SB734-4
2SC3733
2SB774-34

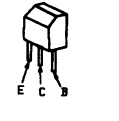

2SC2611
2SC2688-LK
2SC3840K



2SC4763 (LB SONY)
2SK1916-53-F50
2SK1916-53-F87

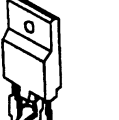

01N20R
ERA38-06
ERA81-004
ERA82-004
REA83-006
ERA85-009
R010ESB2
R013ESB2
R02.2ESB
R02.2ESB2
R03.6ESB1
R033ESB2
R039ESB2
R039ESB4
R05.1ESB
R05.1ESB1
R05.1SB1-T1
R05.6ESB
R05.6ESB1
R05.6ESB2
R06.2ESB2
R06.8ESB1
R06.8SB1-T1
R07.5ESB
R07.5ESB2
R09.1ESB
R09.1ESL
1SS119

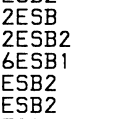

EGP100
ERB24-060TP1
ERC91-02
RGP02-20EL-6394

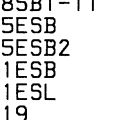

EGP20G
EL1Z
GP080
RGP02-17EL-6433
RGP02-17PKG23
RGP10GPKG23
RGP15GPKG23
RU30A
1SS83

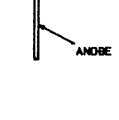

FML-G12S
05L60

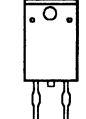

06SB60L

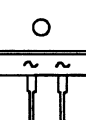

EGP100
ERB24-060TP1
ERC91-02
RGP02-20EL-6394

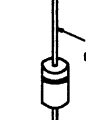

EGP20G
EL1Z
GP080
RGP02-17EL-6433
RGP02-17PKG23
RGP10GPKG23
RGP15GPKG23
RU30A
1SS83

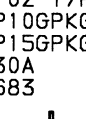

EGP100
ERB24-060TP1
ERC91-02
RGP02-20EL-6394

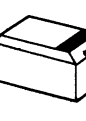

MA110

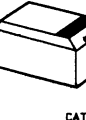

PC-111YS

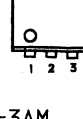

RU-3AM

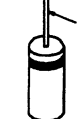

SH0R3042

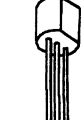

S1BV10-S
S1BV40

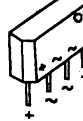

SECTION 8 EXPLODED VIEWS

NOTE:

- Items with no part number and no description are not stocked because they are seldom required for routine service.
- The construction parts of an assembled part are indicated with a collation number in the remark column.
- Items marked " * " are not stocked since they are seldom required for routine service. Some delay should be anticipated when ordering these items.

The components identified by shading and mark Δ are critical for safety. Replace only with part number specified.

Les composants identifiés par une trame et une marque Δ sont critiques pour la sécurité. Ne les remplacer que par une pièce portant le numéro spécifié.

8-1. REAR COVER

- ▲: BVTP 4 x 12 7-685-661-79
- : BVTP 4 x 16 7-685-663-79

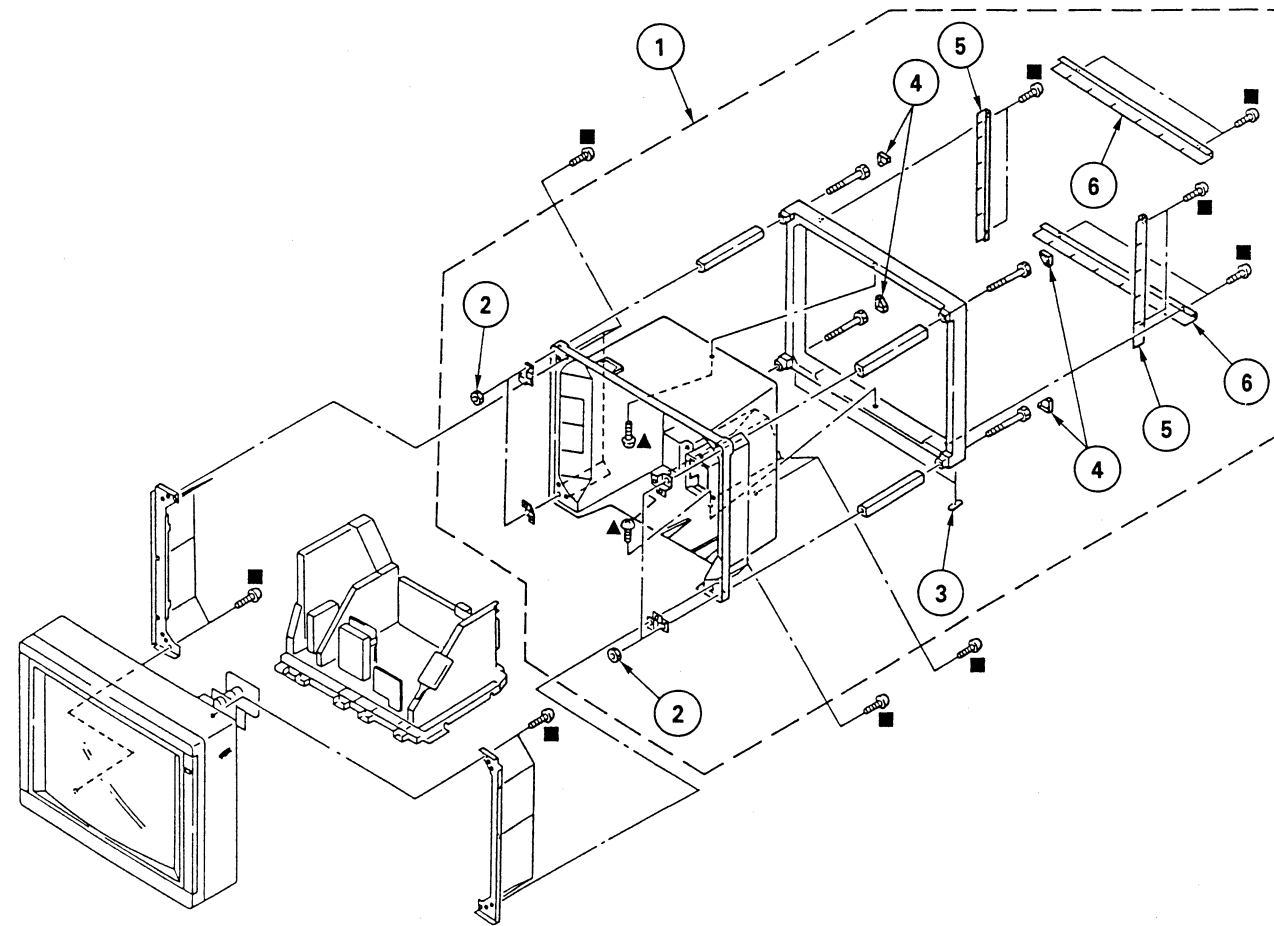

REF. NO.	PART NO.	DESCRIPTION	REMARK
1	X-4032-023-1	COVER ASSY, REAR	2-6
2	4-304-511-00	NUT (M5), FLANGE	
3	4-392-860-01	CUSHION (B)	
4	4-039-913-01	CAP	
5	4-039-918-01	BRACKET (V), REAR FRAME	
6	4-039-917-01	BRACKET (H), REAR FRAME	

8-2. PICTURE TUBE

- : BVTP 3 x 12 7-685-648-79
- : BV 3 x 25 7-685-152-19

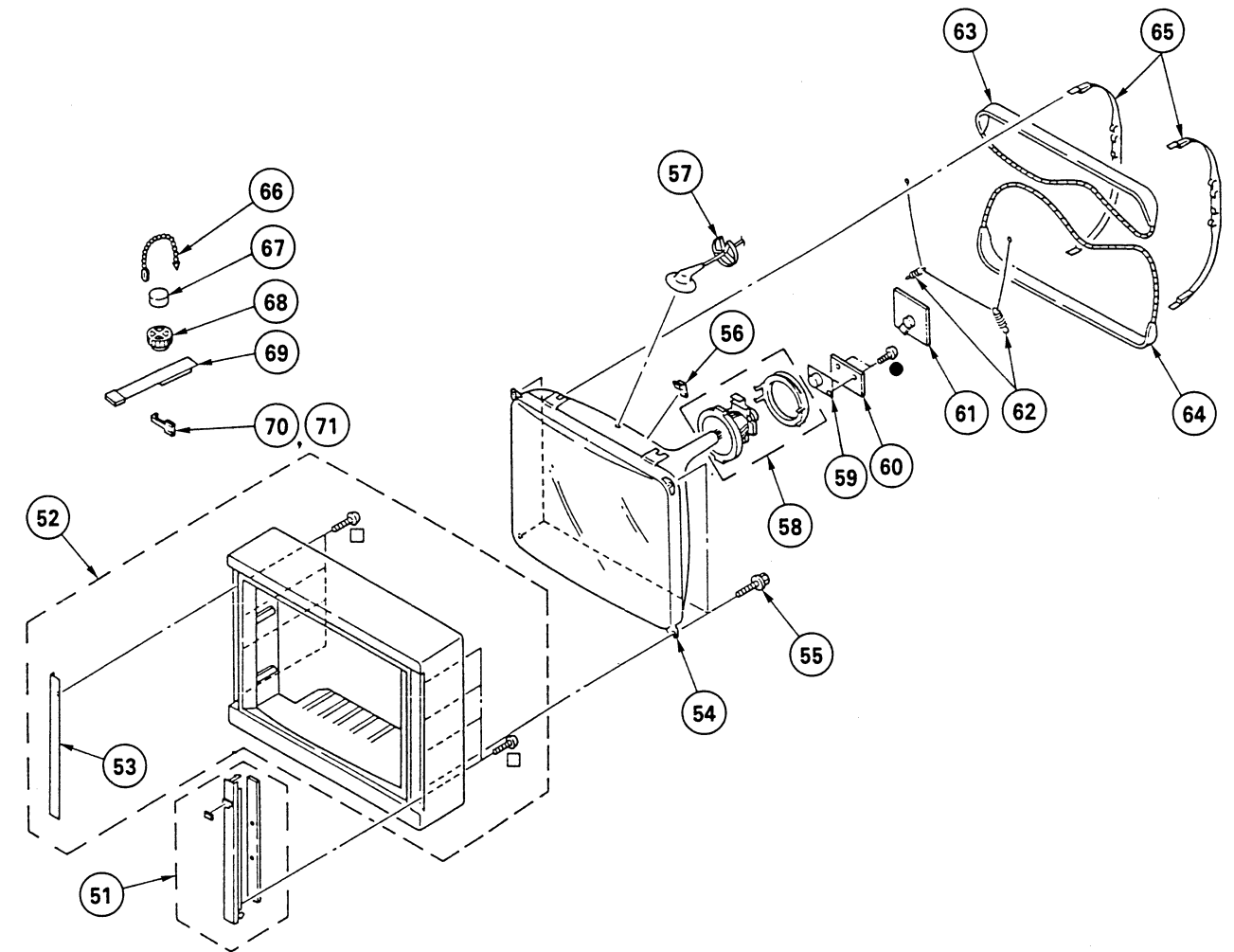

The components identified by shading and mark Δ are critical for safety. Replace only with part number specified.

Les composants identifiés par une trame et une marque Δ sont critiques pour la sécurité. Ne les remplacer que par une pièce portant le numéro spécifié.

REF. NO.	PART NO.	DESCRIPTION	REMARK	REF. NO.	PART NO.	DESCRIPTION	REMARK
51	1-467-794-11	KEY BOARD UNIT		63	Δ 1-402-715-21	COIL, DEMAGNETIZATION (PVM-2950QM)	
52	X-4032-024-1	BEZNET ASSY	53	Δ 1-426-573-22	COIL, DEGAUSSING (PVM-2950Q)		
53	4-045-431-01	PANEL, BLIND		64	Δ 1-402-716-21	COIL, DEMAGNETIZATION (PVM-2950QM)	
54	Δ 8-733-845-05	PICTURE TUBE (M68KUZ10X)		Δ 1-426-574-22	COIL, DEGAUSSING (PVM-2950Q)		
55	4-390-505-01	SCREW (7), TAPPING		65	4-037-983-01	HOLDER, DGC	
56	3-704-495-01	SPACER, DY		66	4-308-870-00	CLIP, LEAD WIRE	
57	*3-704-372-01	HOLDER, HV CABLE		67	1-452-032-00	MAGNET, DISK; 10MM ϕ	
58	Δ 8-451-394-31	DEFLECTION YOKE (Y29EXA)		68	1-452-094-00	MAGNET, ROTATABLE DISK; 15MM ϕ	
59	Δ 1-452-616-13	NECK ASSY, PICTURE TUBE (NA323)		69	X-4306-312-0	PERMALLOY ASSY, CONVERGENCE	
60	*A-1342-246-A	V BOARD, COMPLETE		70	4-034-272-01	PLATE, CORRECTION, TLV	
61	*A-1331-344-A	C BOARD, COMPLETE		71	4-034-272-11	PLATE, CORRECTION, TLV	
62	4-369-318-00	SPRING, TENSION					

8-3. CHASSIS

- : BVTP 3 × 12 7-685-648-79
- : BVTP 4 × 16 7-685-663-79

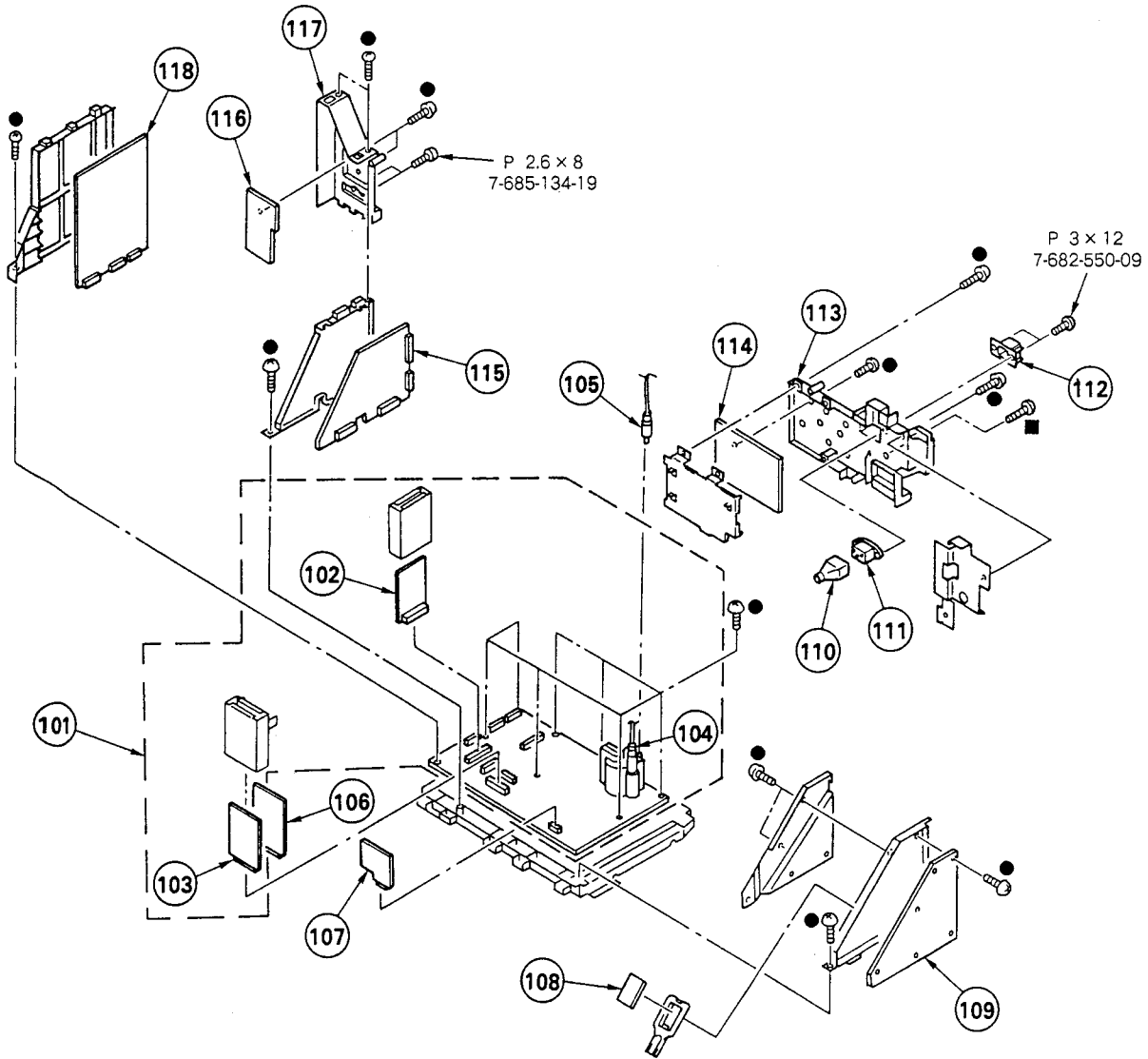

The components identified by shading and mark Δ are critical for safety. Replace only with part number specified.

Les composants identifiés par une trame et une marque Δ sont critiques pour la sécurité. Ne les remplacer que par une pièce portant le numéro spécifié.

REF.NO.	PART NO.	DESCRIPTION	REMARK	REF.NO.	PART NO.	DESCRIPTION	REMARK
101	*A-1297-256-A	A BOARD, COMPLETE (PVM-2950QM(AEP))		110	4-601-466-11	COVER, 3P INLET	
	*A-1297-382-A	A BOARD, COMPLETE (PVM-2950QM(AUS))	102, 103	111	Δ 1-580-375-11	INLET 3P	
	*A-1297-387-A	A BOARD, COMPLETE (PVM-2950Q)	102, 103	112	2-990-241-02	HOLDER (A), PLUG	
102	*A-1301-950-A	M BOARD, COMPLETE		113	4-045-440-01	BRACKET, UJ	
103	*A-1341-764-A	DX BOARD, COMPLETE		114	*A-1373-468-A	UJ BOARD, COMPLETE	
104	Δ X-4032-250-1	TRANSFORMER ASSY, FLYBACK		115	*A-1394-545-A	UT BOARD, COMPLETE	
105	1-900-140-13	LEAD ASSY, FOCUS		116	*A-1373-467-A	UA BOARD, COMPLETE	
106	*A-1347-093-A	VC BOARD, COMPLETE		117	4-045-439-01	BRACKET, UA	
107	*A-1372-005-A	H3 BOARD, COMPLETE		118	*A-1135-787-A	B BOARD, COMPLETE	
108	*A-1311-363-A	G1 BOARD, COMPLETE (PVM-2950Q)					
	*A-1311-365-A	G1 BOARD, COMPLETE (PVM-2950QM)					
109	*A-1316-181-A	G BOARD, COMPLETE (PVM-2950Q)					
	*A-1316-182-A	G BOARD, COMPLETE (PVM-2950QM)					

SECTION 9
ELECTRICAL PARTS LIST

B

NOTE:

The components identified by shading and mark Δ are critical for safety.

Replace only with part number specified.

Les composants identifiés par une trame et une marque Δ sont critiques pour la sécurité. Ne les remplacer que par une pièce portant le numéro spécifié.

• Items marked " * " are not stocked since they are seldom required for routine service. Some delay should be anticipated when ordering these items.

• All variable and adjustable resistors have characteristic curve B, unless otherwise noted.

RESISTORS

• All resistors are in ohms
• F : nonflammable

When indicating parts by reference number, please include the board name.

CAPACITORS

• MF : μ F, PF : μ PF

COILS

• MMH : mH, UH : μ H

• The components identified by \boxtimes in this manual have been carefully factory-selected for each set in order to satisfy regulations regarding X-ray radiation. Should replacement be required, replace only with the value originally used.

• There are some cases the reference number on one board overlaps on the other board. Therefore, when ordering parts by the reference number, please include the board name.

REF. NO.	PART NO.	DESCRIPTION	REMARK	REF. NO.	PART NO.	DESCRIPTION	REMARK
*A-1135-787-A	B BOARD, COMPLETE	*****					
	<CAPACITOR>						
C301	1-124-126-00	ELECT 47MF	20%	C348	1-163-129-00	CERAMIC CHIP 330PF	5% 50V
C302	1-163-035-00	CERAMIC CHIP 0.047MF		C349	1-163-243-11	CERAMIC CHIP 47PF	5% 50V
C303	1-126-964-11	ELECT 10MF	20%	C350	1-163-243-11	CERAMIC CHIP 47PF	5% 50V
C304	1-124-126-00	ELECT 47MF	20%	C351	1-163-129-00	CERAMIC CHIP 330PF	5% 50V
C305	1-126-933-11	ELECT 100MF	20%	C352	1-163-009-11	CERAMIC CHIP 0.001MF	10% 50V
C306	1-163-035-00	CERAMIC CHIP 0.047MF		C353	1-137-374-11	FILM 0.047MF	5% 50V
C307	1-137-375-11	FILM 0.068MF	5%	C354	1-137-374-11	FILM 0.047MF	5% 50V
C308	1-124-903-11	ELECT 1MF	20%	C355	1-124-903-11	ELECT 1MF	20% 50V
C309	1-163-139-00	CERAMIC CHIP 820PF	5%	C356	1-124-902-00	ELECT 0.47MF	20% 50V
C310	1-163-139-00	CERAMIC CHIP 820PF	5%	C357	1-164-232-11	CERAMIC CHIP 0.01MF	10% 50V
C311	1-124-925-11	ELECT 2.2MF	20%	C358	1-163-031-11	CERAMIC CHIP 0.01MF	5% 50V
C312	1-163-121-00	CERAMIC CHIP 150PF	5%	C359	1-163-237-11	CERAMIC CHIP 27PF	5% 50V
C313	1-124-126-00	ELECT 47MF	20%	C360	1-163-031-11	CERAMIC CHIP 0.01MF	5% 50V
C315	1-163-035-00	CERAMIC CHIP 0.047MF		C361	1-130-483-00	MYLAR 0.01MF	5% 50V
C316	1-163-117-00	CERAMIC CHIP 100PF	5%	C362	1-124-927-11	ELECT 4.7MF	20% 50V
C317	1-163-035-00	CERAMIC CHIP 0.047MF		C363	1-124-126-00	ELECT 47MF	20% 16V
C318	1-124-126-00	ELECT 47MF	20%	C364	1-163-031-11	CERAMIC CHIP 0.01MF	5% 50V
C319	1-163-117-00	CERAMIC CHIP 100PF	5%	C365	1-124-903-11	ELECT 1MF	20% 50V
C320	1-130-483-00	MYLAR 0.01MF	5%	C366	1-163-031-11	CERAMIC CHIP 0.01MF	5% 50V
C321	1-124-903-11	ELECT 1MF	20%	C367	1-164-232-11	CERAMIC CHIP 0.01MF	10% 50V
C322	1-124-903-11	ELECT 1MF	20%	C368	1-163-031-11	CERAMIC CHIP 0.01MF	5% 50V
C323	1-130-483-00	MYLAR 0.01MF	5%	C369	1-163-031-11	CERAMIC CHIP 0.01MF	5% 50V
C324	1-124-903-11	ELECT 1MF	20%	C370	1-137-364-11	FILM 0.001MF	5% 50V
C325	1-124-903-11	ELECT 1MF	20%	C371	1-124-126-00	ELECT 47MF	20% 16V
C326	1-137-368-11	FILM 0.0047MF	5%	C372	1-163-035-00	CERAMIC CHIP 0.047MF	5% 50V
C327	1-163-121-00	CERAMIC CHIP 150PF	5%	C373	1-124-126-00	ELECT 47MF	20% 16V
C328	1-137-378-11	FILM 0.22MF	5%	C374	1-163-235-11	CERAMIC CHIP 22PF	5% 50V
C329	1-124-126-00	ELECT 47MF	20%	C379	1-137-399-11	FILM 0.1MF	5% 50V
C330	1-137-372-11	FILM 0.022MF	5%	C380	1-163-019-00	CERAMIC CHIP 0.0068MF	10% 50V
C331	1-124-925-11	ELECT 2.2MF	20%	C381	1-126-964-11	ELECT 10MF	20% 50V
C332	1-163-249-11	CERAMIC CHIP 82PF	5%	C382	1-124-126-00	ELECT 47MF	20% 16V
C333	1-137-365-11	FILM 0.0015MF	5%	C383	1-137-399-11	FILM 0.1MF	5% 50V
C334	1-124-126-00	ELECT 47MF	20%	C384	1-163-113-00	CERAMIC CHIP 68PF	5% 50V
C335	1-163-035-00	CERAMIC CHIP 0.047MF		C385	1-163-103-00	CERAMIC CHIP 27PF	5% 50V
C336	1-126-933-11	ELECT 100MF	20%	C386	1-163-119-00	CERAMIC CHIP 120PF	5% 50V
C337	1-124-126-00	ELECT 47MF	20%	C387	1-136-165-00	FILM 0.1MF	5% 50V
C338	1-124-126-00	ELECT 47MF	20%	C388	1-130-489-00	FILM 0.033MF	5% 50V
C339	1-124-126-00	ELECT 47MF	20%	C389	1-124-126-00	ELECT 47MF	20% 16V
C340	1-124-126-00	ELECT 47MF	20%	C390	1-164-232-11	CERAMIC CHIP 0.01MF	10% 50V
C341	1-124-126-00	ELECT 47MF	20%	C391	1-163-125-00	CERAMIC CHIP 220PF	5% 50V
C342	1-124-126-00	ELECT 47MF	20%	C392	1-163-119-00	CERAMIC CHIP 120PF	5% 50V
C343	1-124-126-00	ELECT 47MF	20%	C393	1-163-101-00	CERAMIC CHIP 22PF	5% 50V
C344	1-124-126-00	ELECT 47MF	20%	C394	1-163-235-11	CERAMIC CHIP 22PF	5% 50V
C345	1-124-126-00	ELECT 47MF	20%	C395	1-163-035-00	CERAMIC CHIP 0.047MF	5% 50V
C346	1-163-035-00	CERAMIC CHIP 0.047MF		C396	1-124-126-00	ELECT 47MF	20% 16V
C347	1-164-232-11	CERAMIC CHIP 0.01MF	10%	C397	1-137-399-11	FILM 0.1MF	5% 50V
				C398	1-137-399-11	FILM 0.1MF	5% 50V
				C399	1-163-119-00	CERAMIC CHIP 120PF	5% 50V
				C400	1-163-097-00	CERAMIC CHIP 15PF	5% 50V
				C401	1-163-097-00	CERAMIC CHIP 15PF	5% 50V
				C402	1-124-126-00	ELECT 47MF	20% 16V

B

REF. NO.	PART NO.	DESCRIPTION	REMARK	REF. NO.	PART NO.	DESCRIPTION	REMARK
IC319	8-759-300-71	IC HD14053BFP					
IC320	8-759-300-71	IC HD14053BFP					
<COIL>							
L301	1-408-411-00	INDUCTOR	15UH				
L302	1-408-411-00	INDUCTOR	15UH				
L303	1-408-411-00	INDUCTOR	15UH				
L304	1-408-405-00	INDUCTOR	4.7UH				
L305	1-408-401-00	INDUCTOR	2.2UH				
L306	1-408-401-00	INDUCTOR	2.2UH				
L307	1-408-409-00	INDUCTOR	10UH				
L308	1-410-476-11	INDUCTOR	33UH				
L309	1-408-409-00	INDUCTOR	10UH				
L310	1-408-609-41	INDUCTOR	33UH				
L311	1-408-411-00	INDUCTOR	15UH				
<VARIABLE COIL>							
LV301	1-404-496-00	COIL					
LV302	1-404-496-00	COIL					
<TRANSISTOR>							
Q301	8-729-216-22	TRANSISTOR	2SA1162-G				
Q302	8-729-120-28	TRANSISTOR	2SC1623-L5L6				
Q303	8-729-216-22	TRANSISTOR	2SA1162-G				
Q304	8-729-120-28	TRANSISTOR	2SC1623-L5L6				
Q305	8-729-120-28	TRANSISTOR	2SC1623-L5L6				
Q306	8-729-120-28	TRANSISTOR	2SC1623-L5L6				
Q307	8-729-120-28	TRANSISTOR	2SC1623-L5L6				
Q308	8-729-120-28	TRANSISTOR	2SC1623-L5L6				
Q309	8-729-216-22	TRANSISTOR	2SA1162-G				
Q311	8-729-216-22	TRANSISTOR	2SA1162-G				
Q312	8-729-216-22	TRANSISTOR	2SA1162-G				
Q313	8-729-120-28	TRANSISTOR	2SC1623-L5L6				
Q314	8-729-216-22	TRANSISTOR	2SA1162-G				
Q315	8-729-216-22	TRANSISTOR	2SA1162-G				
Q316	8-729-120-28	TRANSISTOR	2SC1623-L5L6				
Q317	8-729-120-28	TRANSISTOR	2SC1623-L5L6				
Q318	8-729-120-28	TRANSISTOR	2SC1623-L5L6				
Q319	8-729-216-22	TRANSISTOR	2SA1162-G				
Q320	8-729-216-22	TRANSISTOR	2SA1162-G				
Q321	8-729-120-28	TRANSISTOR	2SC1623-L5L6				
Q322	8-729-120-28	TRANSISTOR	2SC1623-L5L6				
Q323	8-729-216-22	TRANSISTOR	2SA1162-G				
Q324	8-729-216-22	TRANSISTOR	2SA1162-G				
Q325	8-729-120-28	TRANSISTOR	2SC1623-L5L6				
Q326	8-729-120-28	TRANSISTOR	2SC1623-L5L6				
Q327	8-729-216-22	TRANSISTOR	2SA1162-G				
Q328	8-729-120-28	TRANSISTOR	2SC1623-L5L6				
Q329	8-729-120-28	TRANSISTOR	2SC1623-L5L6				
Q330	8-729-120-28	TRANSISTOR	2SC1623-L5L6				
Q331	8-729-120-28	TRANSISTOR	2SC1623-L5L6				
Q332	8-729-120-28	TRANSISTOR	2SC1623-L5L6				
Q333	8-729-216-22	TRANSISTOR	2SA1162-G				
Q334	8-729-120-28	TRANSISTOR	2SC1623-L5L6				
Q335	8-729-216-22	TRANSISTOR	2SA1162-G				
Q336	8-729-120-28	TRANSISTOR	2SC1623-L5L6				
Q337	8-729-120-28	TRANSISTOR	2SC1623-L5L6				
Q338	8-729-216-22	TRANSISTOR	2SA1162-G				
Q339	8-729-216-22	TRANSISTOR	2SA1162-G				
Q340	8-729-216-22	TRANSISTOR	2SA1162-G				
Q341	8-729-216-22	TRANSISTOR	2SA1162-G				
Q342	8-729-216-22	TRANSISTOR	2SA1162-G				
Q343	8-729-216-22	TRANSISTOR	2SA1162-G				
Q344	8-729-901-01	TRANSISTOR	DTC144EK				
Q345	8-729-901-01	TRANSISTOR	DTC144EK				
Q346	8-729-120-28	TRANSISTOR	2SC1623-L5L6				
Q347	8-729-901-01	TRANSISTOR	DTC144EK				
Q348	8-729-901-01	TRANSISTOR	DTC144EK				
Q349	8-729-901-01	TRANSISTOR	DTC144EK				
Q352	8-729-120-28	TRANSISTOR	2SC1623-L5L6				
Q354	8-729-901-01	TRANSISTOR	DTC144EK				
Q355	8-729-901-01	TRANSISTOR	DTC144EK				
Q356	8-729-216-22	TRANSISTOR	2SA1162-G				
Q357	8-729-216-22	TRANSISTOR	2SA1162-G				
Q358	8-729-901-01	TRANSISTOR	DTC144EK				
Q359	8-729-120-28	TRANSISTOR	2SC1623-L5L6				
Q361	8-729-901-01	TRANSISTOR	DTC144EK				
Q362	8-729-120-28	TRANSISTOR	2SC1623-L5L6				
Q363	8-729-901-01	TRANSISTOR	DTC144EK				
<RESISTOR>							
JR306	1-216-295-91	METAL GLAZE	0 5% 1/10W				
JR308	1-216-295-91	METAL GLAZE	0 5% 1/10W				
JR309	1-216-295-91	METAL GLAZE	0 5% 1/10W				
JR321	1-216-295-91	METAL GLAZE	0 5% 1/10W				
JR322	1-216-295-91	METAL GLAZE	0 5% 1/10W				
JR323	1-216-296-91	METAL GLAZE	0 5% 1/8W				
JR324	1-216-296-91	METAL GLAZE	0 5% 1/8W				
JR325	1-216-296-91	METAL GLAZE	0 5% 1/8W				
JR326	1-216-296-91	METAL GLAZE	0 5% 1/8W				
JR327	1-216-296-91	METAL GLAZE	0 5% 1/8W				
JR328	1-216-296-91	METAL GLAZE	0 5% 1/8W				
JR329	1-216-296-91	METAL GLAZE	0 5% 1/8W				
JR330	1-216-295-91	METAL GLAZE	0 5% 1/10W				
JR331	1-216-296-91	METAL GLAZE	0 5% 1/8W				
JR332	1-216-295-91	METAL GLAZE	0 5% 1/10W				
JR333	1-216-296-91	METAL GLAZE	0 5% 1/8W				
JR334	1-216-296-91	METAL GLAZE	0 5% 1/8W				
JR356	1-216-296-91	METAL GLAZE	0 5% 1/8W				
JR360	1-216-295-91	METAL GLAZE	0 5% 1/10W				
JR520	1-216-296-91	METAL GLAZE	0 5% 1/8W				
JR521	1-216-295-91	METAL GLAZE	0 5% 1/10W				
JR524	1-216-296-91	METAL GLAZE	0 5% 1/8W				
JR525	1-216-295-91	METAL GLAZE	0 5% 1/10W				
JR526	1-216-295-91	METAL GLAZE	0 5% 1/10W				
JR529	1-216-295-91	METAL GLAZE	0 5% 1/10W				
R301	1-216-049-00	METAL GLAZE	1K 5% 1/10W				
R302	1-216-049-00	METAL GLAZE	1K 5% 1/10W				
R303	1-216-067-00	METAL GLAZE	5.6K 5% 1/10W				
R304	1-216-061-00	METAL GLAZE	3.3K 5% 1/10W				
R305	1-216-647-11	METAL CHIP	680 0.50% 1/10W				
R306	1-216-647-11	METAL CHIP	680 0.50% 1/10W				
R307	1-216-025-00	METAL GLAZE	100 5% 1/10W				
R308	1-216-067-00	METAL GLAZE	5.6K 5% 1/10W				
R309	1-216-043-00	METAL GLAZE	560 5% 1/10W				
R310	1-216-105-00	METAL GLAZE	220K 5% 1/10W				
R311	1-216-081-00	METAL GLAZE	22K 5% 1/10W				
R312	1-216-049-00	METAL GLAZE	1K 5% 1/10W				
R313	1-216-051-00	METAL GLAZE	1.2K 5% 1/10W				
R314	1-216-067-00	METAL GLAZE	5.6K 5% 1/10W				
R315	1-216-049-00	METAL GLAZE	1K 5% 1/10W				
R316	1-216-075-00	METAL GLAZE	12K 5% 1/10W				
R317	1-216-049-00	METAL GLAZE	1K 5% 1/10W				

B

REF. NO.	PART NO.	DESCRIPTION	REMARK	REF. NO.	PART NO.	DESCRIPTION	REMARK
R318	1-216-133-00	METAL GLAZE	3.3M 5% 1/10W	R384	1-216-081-00	METAL GLAZE	22K 5% 1/10W
R319	1-216-045-00	METAL GLAZE	680 5% 1/10W	R385	1-216-113-00	METAL GLAZE	470K 5% 1/10W
R320	1-216-057-00	METAL GLAZE	2.2K 5% 1/10W	R386	1-216-065-00	METAL GLAZE	4.7K 5% 1/10W
R321	1-216-065-00	METAL GLAZE	4.7K 5% 1/10W	R387	1-216-689-11	METAL GLAZE	39K 5% 1/10W
R322	1-216-069-00	METAL GLAZE	6.8K 5% 1/10W	R388	1-216-067-00	METAL GLAZE	5.6K 5% 1/10W
R323	1-216-097-00	METAL GLAZE	100K 5% 1/10W	R389	1-216-041-00	METAL GLAZE	470 5% 1/10W
R324	1-216-079-00	METAL GLAZE	18K 5% 1/10W	R390	1-216-095-00	METAL GLAZE	82K 5% 1/10W
R325	1-216-057-00	METAL GLAZE	2.2K 5% 1/10W	R391	1-216-103-91	METAL GLAZE	180K 5% 1/10W
R326	1-216-065-00	METAL GLAZE	4.7K 5% 1/10W	R392	1-216-679-11	METAL CHIP	15K 0.50% 1/10W
R327	1-216-063-00	METAL GLAZE	3.9K 5% 1/10W	R393	1-216-667-11	METAL CHIP	4.7K 0.50% 1/10W
R328	1-216-069-00	METAL GLAZE	6.8K 5% 1/10W	R394	1-216-065-00	METAL GLAZE	4.7K 5% 1/10W
R329	1-216-041-00	METAL GLAZE	470 5% 1/10W	R395	1-216-113-00	METAL GLAZE	470K 5% 1/10W
R330	1-216-045-00	METAL GLAZE	680 5% 1/10W	R396	1-216-133-00	METAL GLAZE	3.3M 5% 1/10W
R331	1-216-089-91	METAL GLAZE	47K 5% 1/10W	R397	1-216-051-00	METAL GLAZE	1.2K 5% 1/10W
R332	1-216-115-00	METAL GLAZE	560K 5% 1/10W	R398	1-216-093-00	METAL GLAZE	68K 5% 1/10W
R334	1-216-033-00	METAL GLAZE	220 5% 1/10W	R399	1-216-095-00	METAL GLAZE	82K 5% 1/10W
R335	1-216-053-00	METAL GLAZE	1.5K 5% 1/10W	R400	1-216-109-00	METAL GLAZE	330K 5% 1/10W
R336	1-216-073-00	METAL GLAZE	10K 5% 1/10W	R401	1-216-105-00	METAL GLAZE	220K 5% 1/10W
R337	1-216-069-00	METAL GLAZE	6.8K 5% 1/10W	R402	1-216-101-00	METAL GLAZE	150K 5% 1/10W
R339	1-216-071-00	METAL GLAZE	8.2K 5% 1/10W	R403	1-216-097-00	METAL GLAZE	100K 5% 1/10W
R340	1-216-061-00	METAL GLAZE	3.3K 5% 1/10W	R404	1-216-101-00	METAL GLAZE	150K 5% 1/10W
R341	1-216-091-00	METAL GLAZE	56K 5% 1/10W	R405	1-216-101-00	METAL GLAZE	150K 5% 1/10W
R342	1-216-073-00	METAL GLAZE	10K 5% 1/10W	R406	1-216-065-00	METAL GLAZE	4.7K 5% 1/10W
R343	1-216-103-91	METAL GLAZE	180K 5% 1/10W	R407	1-216-073-00	METAL GLAZE	10K 5% 1/10W
R344	1-216-113-00	METAL GLAZE	470K 5% 1/10W	R408	1-216-077-00	METAL GLAZE	15K 5% 1/10W
R345	1-216-103-91	METAL GLAZE	180K 5% 1/10W	R409	1-216-029-00	METAL GLAZE	150 5% 1/10W
R346	1-216-107-00	METAL GLAZE	270K 5% 1/10W	R410	1-216-029-00	METAL GLAZE	150 5% 1/10W
R347	1-216-097-00	METAL GLAZE	100K 5% 1/10W	R411	1-216-041-00	METAL GLAZE	470 5% 1/10W
R348	1-216-113-00	METAL GLAZE	470K 5% 1/10W	R412	1-216-053-00	METAL GLAZE	1.5K 5% 1/10W
R349	1-216-061-00	METAL GLAZE	3.3K 5% 1/10W	R413	1-216-065-00	METAL GLAZE	4.7K 5% 1/10W
R350	1-216-075-00	METAL GLAZE	12K 5% 1/10W	R414	1-216-065-00	METAL GLAZE	4.7K 5% 1/10W
R351	1-216-057-00	METAL GLAZE	2.2K 5% 1/10W	R415	1-216-045-00	METAL GLAZE	680 5% 1/10W
R352	1-216-049-00	METAL GLAZE	1K 5% 1/10W	R416	1-216-043-00	METAL GLAZE	560 5% 1/10W
R353	1-216-033-00	METAL GLAZE	220 5% 1/10W	R417	1-216-037-00	METAL GLAZE	330 5% 1/10W
R354	1-216-065-00	METAL GLAZE	4.7K 5% 1/10W	R418	1-216-043-00	METAL GLAZE	560 5% 1/10W
R355	1-216-089-91	METAL GLAZE	47K 5% 1/10W	R419	1-216-037-00	METAL GLAZE	330 5% 1/10W
R356	1-216-033-00	METAL GLAZE	220 5% 1/10W	R420	1-216-047-00	METAL GLAZE	820 5% 1/10W
R357	1-216-033-00	METAL GLAZE	220 5% 1/10W	R421	1-216-069-00	METAL GLAZE	6.8K 5% 1/10W
R358	1-216-073-00	METAL GLAZE	10K 5% 1/10W	R422	1-216-053-00	METAL GLAZE	1.5K 5% 1/10W
R359	1-216-065-00	METAL GLAZE	4.7K 5% 1/10W	R423	1-216-063-00	METAL GLAZE	3.9K 5% 1/10W
R360	1-216-057-00	METAL GLAZE	2.2K 5% 1/10W	R424	1-216-069-00	METAL GLAZE	6.8K 5% 1/10W
R361	1-216-097-00	METAL GLAZE	100K 5% 1/10W	R425	1-216-061-00	METAL GLAZE	3.3K 5% 1/10W
R362	1-216-049-00	METAL GLAZE	1K 5% 1/10W	R426	1-216-069-00	METAL GLAZE	6.8K 5% 1/10W
R363	1-216-093-00	METAL GLAZE	68K 5% 1/10W	R427	1-216-063-00	METAL GLAZE	3.9K 5% 1/10W
R364	1-216-059-00	METAL GLAZE	2.7K 5% 1/10W	R428	1-216-065-00	METAL GLAZE	4.7K 5% 1/10W
R365	1-216-662-11	METAL CHIP	3K 0.50% 1/10W	R429	1-216-055-00	METAL GLAZE	1.8K 5% 1/10W
R366	1-216-017-00	METAL GLAZE	47 5% 1/10W	R430	1-216-039-00	METAL GLAZE	390 5% 1/10W
R367	1-216-065-00	METAL GLAZE	4.7K 5% 1/10W	R431	1-216-059-00	METAL GLAZE	2.7K 5% 1/10W
R368	1-216-041-00	METAL GLAZE	470 5% 1/10W	R432	1-216-071-00	METAL GLAZE	8.2K 5% 1/10W
R369	1-216-041-00	METAL GLAZE	470 5% 1/10W	R433	1-216-031-00	METAL GLAZE	180 5% 1/10W
R370	1-216-049-00	METAL GLAZE	1K 5% 1/10W	R434	1-216-065-00	METAL GLAZE	4.7K 5% 1/10W
R371	1-216-295-91	METAL GLAZE	0 5% 1/10W	R435	1-216-039-00	METAL GLAZE	390 5% 1/10W
R372	1-216-025-00	METAL GLAZE	100 5% 1/10W	R437	1-216-061-00	METAL GLAZE	3.3K 5% 1/10W
R373	1-216-025-00	METAL GLAZE	100 5% 1/10W	R438	1-216-059-00	METAL GLAZE	2.7K 5% 1/10W
R374	1-216-295-91	METAL GLAZE	0 5% 1/10W	R439	1-216-029-00	METAL GLAZE	150 5% 1/10W
R375	1-216-065-00	METAL GLAZE	4.7K 5% 1/10W	R441	1-216-073-00	METAL GLAZE	10K 5% 1/10W
R376	1-216-065-00	METAL GLAZE	4.7K 5% 1/10W	R442	1-216-049-00	METAL GLAZE	1K 5% 1/10W
R377	1-216-067-00	METAL GLAZE	5.6K 5% 1/10W	R443	1-216-049-00	METAL GLAZE	1K 5% 1/10W
R378	1-216-059-00	METAL GLAZE	2.7K 5% 1/10W	R445	1-216-053-00	METAL GLAZE	1.5K 5% 1/10W
R379	1-216-057-00	METAL GLAZE	2.2K 5% 1/10W	R446	1-216-043-00	METAL GLAZE	560 5% 1/10W
R380	1-216-041-00	METAL GLAZE	470 5% 1/10W	R447	1-216-067-00	METAL GLAZE	5.6K 5% 1/10W
R381	1-216-041-00	METAL GLAZE	470 5% 1/10W	R448	1-216-059-00	METAL GLAZE	2.7K 5% 1/10W
R382	1-216-105-00	METAL GLAZE	220K 5% 1/10W	R449	1-216-061-00	METAL GLAZE	3.3K 5% 1/10W
R383	1-216-113-00	METAL GLAZE	470K 5% 1/10W				

The components identified by shading and mark Δ are critical for safety.
Replace only with part number specified.

Les composants identifiés par une trame et une marque Δ sont critiques pour la sécurité.
Ne les remplacer que par une pièce portant le numéro spécifié.



REF. NO.	PART NO.	DESCRIPTION	REMARK	REF. NO.	PART NO.	DESCRIPTION	REMARK
*A-1297-256-A	A BOARD, COMPLETE (PVM-2950Q(AEP))			C574	1-107-650-11	ELECT	3.3MF 20% 250V
*A-1297-382-A	A BOARD, COMPLETE (PVM-2950Q(AUS))			C575	1-102-038-00	CERAMIC	0.001MF 500V
*A-1297-387-A	A BOARD, COMPLETE (PVM-2950Q)			C576	1-124-797-11	ELECT	0.47MF 20% 160V
4-382-854-01	SCREW (M3X8), P, SW (+)			C577	1-123-950-00	ELECT	47MF 20% 250V
	<CAPACITOR>			C578	1-123-024-21	ELECT	33MF 160V
C517	1-106-391-12	MYLAR	0.1MF 10% 200V	C579	1-104-664-11	ELECT	47MF 20% 25V
C518	1-128-577-11	ELECT	0.47MF 20% 100V	C581	1-130-491-00	MYLAR	0.047MF 5% 50V
C519	1-102-110-00	CERAMIC	220PF 10% 50V	C582	1-126-803-11	ELECT	47MF 20% 50V
C520	1-162-318-11	CERAMIC	0.001MF 10% 500V	C583	1-102-114-00	CERAMIC	470PF 10% 50V
C521	1-162-117-00	CERAMIC	100PF 10% 500V	C584	1-136-171-00	FILM	0.33MF 5% 50V
C522 Δ	1-162-116-00	CERAMIC	680PF 10% 2KV	C585	1-128-528-11	ELECT	470MF 20% 25V
C523 Δ	1-137-604-11	FILM	0.022MF 2% 2KV	C586	1-126-969-11	ELECT	220MF 20% 50V
C524 Δ	1-162-116-00	CERAMIC	680PF 10% 2KV	C590	1-130-471-00	MYLAR	0.001MF 5% 50V
C525 Δ	1-137-515-11	FILM	0.056MF 3% 400V	C591	1-130-467-00	MYLAR	470PF 5% 50V
C526	1-137-114-11	FILM	0.68MF 5% 200V	C593	1-104-664-11	ELECT	47MF 20% 25V
C527	1-106-343-00	MYLAR	0.001MF 10% 100V	C594	1-104-664-11	ELECT	47MF 20% 25V
C528	1-136-105-00	FILM	0.33MF 5% 200V	C595	1-104-664-11	ELECT	47MF 20% 25V
C529	1-104-709-11	ELECT	4.7MF 0 160V	C596	1-124-126-00	ELECT	47MF 20% 16V
C530	1-137-516-11	FILM	1.2MF 5% 200V	C597	1-109-889-11	ELECT	1MF 20% 50V
C531	1-137-116-11	FILM	1MF 5% 200V	C598	1-124-126-00	ELECT	47MF 20% 16V
C532	1-107-652-11	ELECT	10MF 20% 250V	C599	1-106-222-00	MYLAR	0.12MF 10% 100V
C533 Δ	1-162-116-00	CERAMIC	680PF 10% 2KV	C600	1-126-157-11	ELECT	10MF 20% 16V
C535	1-136-165-00	FILM	0.1MF 5% 50V	C601	1-126-967-11	ELECT	47MF 20% 50V
C536	1-124-927-11	ELECT	4.7MF 20% 50V	C602	1-126-157-11	ELECT	10MF 20% 16V
C537	1-106-355-12	MYLAR	0.0033MF 10% 200V	C603	1-126-157-11	ELECT	10MF 20% 16V
C538	1-130-487-00	MYLAR	0.022MF 5% 50V	C604	1-126-967-11	ELECT	47MF 20% 50V
C539	1-136-173-00	FILM	0.47MF 5% 50V	C605	1-126-967-11	ELECT	47MF 20% 50V
C542	1-130-471-00	FILM	0.001MF 5% 50V	C606	1-124-126-00	ELECT	47MF 20% 16V
C543	1-136-161-00	FILM	0.047MF 5% 50V	C607	1-126-953-11	ELECT	2200MF 20% 35V
C545	1-126-964-11	ELECT	10MF 20% 50V	C608	1-126-952-11	ELECT	1000MF 20% 35V
C546	1-130-471-00	MYLAR	0.001MF 5% 50V	C609	1-126-953-11	ELECT	2200MF 20% 35V
C547	1-106-343-00	FILM	0.001MF 5% 100V	C610	1-136-165-00	FILM	0.1MF 5% 50V
C548	1-124-902-00	ELECT	0.47MF 20% 50V	C611	1-136-165-00	FILM	0.1MF 5% 50V
C549	1-130-471-00	MYLAR	0.001MF 5% 50V	C612	1-126-157-11	ELECT	10MF 20% 16V
C550	1-104-664-11	ELECT	47MF 20% 25V	C613	1-126-953-11	ELECT	2200MF 20% 35V
C551	1-104-664-11	ELECT	47MF 20% 25V	C614	1-124-126-00	ELECT	47MF 20% 16V
C552	1-126-964-11	ELECT	10MF 20% 50V	C615	1-136-177-00	FILM	1MF 5% 50V
C553	1-136-161-00	FILM	0.047MF 5% 50V	C617	1-107-910-11	ELECT	100MF 20% 50V
C554	1-136-161-00	FILM	0.047MF 5% 50V	C618	1-130-495-00	MYLAR	0.1MF 5% 50V
C556	1-126-964-11	ELECT	10MF 20% 50V	C619	1-130-495-00	MYLAR	0.1MF 5% 50V
C557	1-136-169-00	FILM	0.22MF 5% 50V	C620	1-124-598-11	ELECT	22MF 20% 25V
C558	1-129-718-00	FILM	0.022MF 5% 630V	C621	1-124-598-11	ELECT	22MF 20% 25V
C559	1-106-387-00	MYLAR	0.068MF 10% 200V	C622	1-126-934-11	ELECT	220MF 20% 16V
C560	1-129-898-00	FILM	0.0022MF 5% 630V	C630	1-126-964-11	ELECT	10MF 20% 50V
C561	1-102-244-00	CERAMIC	220PF 10% 500V	C631	1-104-665-11	ELECT	100MF 20% 25V
C562	1-129-702-00	FILM	0.001MF 10% 630V	C680	1-162-117-00	CERAMIC	100PF 10% 500V
C563	1-102-228-00	CERAMIC	470PF 10% 500V	C681	1-102-074-00	CERAMIC	0.001MF 10% 50V
C564	1-102-228-00	CERAMIC	470PF 10% 500V	C682	1-136-165-00	FILM	0.1MF 5% 50V
C565	1-126-941-11	ELECT	470MF 20% 25V	C683	1-124-234-00	ELECT	22MF 20% 16V
C566	1-128-528-11	ELECT	470MF 20% 25V	C684	1-102-119-00	CERAMIC	0.0015MF 10% 50V
C567	1-126-925-11	ELECT	470MF 20% 10V	C801	1-124-126-00	ELECT	47MF 20% 16V
C568	1-102-244-00	CERAMIC	220PF 10% 500V	C802	1-124-126-00	ELECT	47MF 20% 16V
C569	1-162-114-00	CERAMIC	0.0047MF 10% 2KV	C804	1-136-153-00	FILM	0.01MF 5% 50V
C570	1-162-116-00	CERAMIC	680PF 10% 2KV	C805	1-136-165-00	FILM	0.1MF 5% 50V
C571	1-162-116-00	CERAMIC	680PF 10% 2KV	C806	1-136-165-00	FILM	0.1MF 5% 50V
C572	1-106-359-00	MYLAR	0.0047MF 10% 200V	C807	1-126-952-11	ELECT	1000MF 20% 16V
C573	1-126-923-11	ELECT	220MF 20% 10V	C809	1-136-104-00	FILM	0.16MF 5% 200V
				C810	1-136-177-00	FILM	1MF 5% 50V
				C811	1-106-343-00	MYLAR	0.001MF 10% 200V
				C812	1-126-964-11	ELECT	10MF 20% 50V
				C813	1-136-161-00	FILM	0.047MF 5% 50V
				C814	1-126-964-11	ELECT	10MF 20% 50V
				C815	1-126-964-11	ELECT	10MF 20% 50V

A

REF. NO.	PART NO.	DESCRIPTION	REMARK	REF. NO.	PART NO.	DESCRIPTION	REMARK
C816	1-124-234-00	ELECT	22MF	20%	16V		
C817	1-124-927-11	ELECT	4.7MF	20%	50V		
C818	1-124-126-00	ELECT	47MF	20%	16V		
C819	1-136-165-00	FILM	0.1MF	5%	50V		
C820	1-126-935-11	ELECT	470MF	20%	16V		
C822	1-126-933-11	ELECT	100MF	20%	10V		
C823	1-106-371-00	MYLAR	0.015MF	10%	100V		
C901	1-136-173-00	FILM	0.47MF	5%	50V		
C902	1-126-964-11	ELECT	10MF	20%	50V		
C903	1-136-169-00	FILM	0.22MF	5%	50V		
C904	1-130-471-00	MYLAR	0.001MF	5%	50V		
C905	1-126-964-11	ELECT	10MF	20%	50V		
C906	1-124-798-11	ELECT	1MF	20%	160V		
C907	1-124-902-00	ELECT	0.47MF	20%	50V		
C908	1-102-112-00	CERAMIC	330PF	10%	50V		
C910	1-136-103-00	FILM	0.1MF	5%	200V		
C911	1-136-165-00	FILM	0.1MF	5%	50V		
C914	1-106-367-00	MYLAR	0.01MF	10%	100V		
C915	1-124-903-11	ELECT	1MF	20%	50V		
C917	1-130-471-00	MYLAR	0.001MF	5%	50V		
C918	1-102-074-00	CERAMIC	0.001MF	10%	50V		
C920	1-136-601-11	FILM	0.01MF	5%	630V		
C923	1-130-471-00	MYLAR	0.001MF	5%	50V		
C925	1-126-964-11	ELECT	10MF	20%	50V		
C926	1-136-165-00	FILM	0.1MF	5%	50V		
C927	1-136-171-00	FILM	0.33MF	5%	50V		
C928	1-126-964-11	ELECT	10MF	20%	50V		
C930	1-136-153-00	FILM	0.01MF	5%	50V		
C932	1-130-475-00	MYLAR	0.0022MF	5%	50V		
C1601	1-102-106-00	CERAMIC	100PF	10%	50V		
C1602	1-102-114-00	CERAMIC	470PF	10%	50V		
C1603	1-130-481-00	MYLAR	0.0068MF	5%	50V		
C1604	1-124-903-11	ELECT	1MF	20%	50V		
C1605	1-124-925-11	ELECT	2.2MF	20%	50V		
C1606	1-130-483-00	MYLAR	0.01MF	5%	50V		
C1607	1-124-903-11	ELECT	1MF	20%	50V		
C1608	1-130-479-00	MYLAR	0.0047MF	5%	50V		
C1610	1-130-499-00	MYLAR	0.22MF	5%	50V		
C1611	1-130-481-00	MYLAR	0.0068MF	5%	50V		
C1612	1-124-927-11	ELECT	4.7MF	20%	50V		
C1613	1-130-475-00	MYLAR	0.0022MF	5%	50V		
C1614	1-126-964-11	ELECT	10MF	20%	50V		
C1620	1-136-161-00	FILM	0.047MF	5%	50V		
C1621	1-102-110-00	CERAMIC	220PF	10%	50V		
C1627	1-136-173-00	FILM	0.47MF	5%	50V		
C1670	1-126-964-11	ELECT	10MF	20%	50V		
C1671	1-101-361-00	CERAMIC	150PF	5%	50V		
C1672	1-101-361-00	CERAMIC	150PF	5%	50V		
C1673	1-101-361-00	CERAMIC	150PF	5%	50V		
C1674	1-124-925-11	ELECT	2.2MF	20%	50V		
C1675	1-136-153-00	FILM	0.01MF	5%	50V		
C1676	1-136-169-00	FILM	0.22MF	5%	50V		
C1677	1-126-964-11	ELECT	10MF	20%	50V		
C1678	1-102-110-00	CERAMIC	220PF	10%	50V		
C1680	1-124-925-11	ELECT	2.2MF	20%	50V		
C1681	1-124-126-00	ELECT	47MF	20%	16V		
C1813	1-136-756-11	FILM	0.24MF	5%	200V		
C1825	1-106-391-12	MYLAR	0.1MF	10%	200V		
<CONNECTOR>							
CN501	*1-573-986-11	PIN, CONNECTOR (PC BOARD) 5P					
CN507	*1-573-964-11	PIN, CONNECTOR (PC BOARD) 6P					
CN508	1-573-297-11	CONNECTOR, BOARD TO BOARD 18P					
CN509	1-573-297-11	CONNECTOR, BOARD TO BOARD 18P					
CN510	1-573-297-11	CONNECTOR, BOARD TO BOARD 18P					
CN511	1-573-297-11	CONNECTOR, BOARD TO BOARD 18P					
CN512	1-573-297-11	CONNECTOR, BOARD TO BOARD 18P					
CN513	*1-564-508-11	PLUG, CONNECTOR 5P					
CN514	*1-564-507-11	PLUG, CONNECTOR 4P					
CN515	*1-564-508-11	PLUG, CONNECTOR 5P					
CN520	*1-564-512-11	PLUG, CONNECTOR 9P					
CN530	1-573-296-11	CONNECTOR, BOARD TO BOARD 10P					
CN1804	*1-508-768-00	PIN, CONNECTOR (5MM PITCH) 6P					
CN1805	1-573-297-11	CONNECTOR, BOARD TO BOARD 18P					
DY1	*1-580-798-11	CONNECTOR PIN (DY) 6P					
DY-2	*1-508-765-00	PIN, CONNECTOR (5MM PITCH) 3P					
<DIODE>							
D505	8-719-110-78	DIODE RD33ESB2					
D506	8-719-911-19	DIODE 1SS119					
D507	8-719-911-19	DIODE 1SS119					
D508	8-719-911-19	DIODE 1SS119					
D509	8-719-970-87	DIODE ERA38-06					
D510	8-719-302-43	DIODE EL1Z					
D511	8-719-300-33	DIODE RU-3AM					
D512	8-719-979-85	DIODE EGP20G					
D513	8-719-312-72	DIODE RU30A					
D515	8-719-302-43	DIODE EL1Z					
D516	8-719-018-82	DIODE RGP02-20EL-6394					
D517	8-719-110-03	DIODE RD7.5ESB2					
D519	8-719-911-19	DIODE 1SS119					
D520	8-719-908-03	DIODE GP08D					
D521	8-719-110-78	DIODE RD33ESB2					
D522	8-719-911-19	DIODE 1SS119					
D523	8-719-911-19	DIODE 1SS119					
D524	8-719-028-72	DIODE RGP02-17EL-6433					
D525	8-719-109-88	DIODE RD5.6ESB1					
D526	8-719-109-93	DIODE RD6.2ESB2					
D530	8-719-510-48	DIODE D1N20R					
D531	8-719-510-48	DIODE D1N20R					
D532	8-719-110-90	DIODE RD39ESB4					
D533	8-719-911-19	DIODE 1SS119					
D534	8-719-911-19	DIODE 1SS119					
D535	8-719-911-19	DIODE 1SS119					
D550	8-719-911-19	DIODE 1SS119					
D551	8-719-981-50	DIODE RB-100A					
D650	8-719-109-88	DIODE RD5.6ESB1					
D652	8-719-911-19	DIODE 1SS119					
D653	8-719-911-19	DIODE 1SS119					
D654	8-719-109-54	DIODE RD2.2ESB2					
D655	8-719-911-19	DIODE 1SS119					
D680	8-719-109-88	DIODE RD5.6ESB1					
D681	8-719-911-19	DIODE 1SS119					
D682	8-719-911-19	DIODE 1SS119 (PVM-2950Q/2950QM(AUS))					
D683	8-719-911-19	DIODE 1SS119 (PVM-2950Q/2950QM(AUS))					
D684	8-719-911-19	DIODE 1SS119					
D801	8-719-987-87	DIODE ERA85-009					
D804	8-719-911-19	DIODE 1SS119					
D805	8-719-801-35	THYRISTOR SHOR3D42					
D806	8-719-980-78	DIODE ERA83-006					
D807	8-719-980-78	DIODE ERA83-006					
D808	8-719-911-19	DIODE 1SS119					
D809	8-719-911-19	DIODE 1SS119					
D810	8-719-911-19	DIODE 1SS119					
D811	8-719-302-43	DIODE EL1Z					

The components identified by shading and mark Δ are critical for safety. Replace only with part number specified.

Les composants identifiés par une trame et une marque Δ sont critiques pour la sécurité. Ne les remplacer que par une pièce portant le numéro spécifié.

PVM-2950Q/2950QM
RM-854

A

REF. NO.	PART NO.	DESCRIPTION	REMARK	REF. NO.	PART NO.	DESCRIPTION	REMARK
D812	8-719-911-19	DIODE 1SS119		L1801	1-459-104-00	COIL, DUST CORE	
D813	8-719-109-88	DIODE RD5.6ESB1		L1802	1-459-390-00	COIL (WITH CORE)	
D814	8-719-121-24	DIODE RD9.1ESL				<TRANSISTOR>	
D816	8-719-911-19	DIODE 1SS119		Q504	8-729-119-80	TRANSISTOR 2SC2688-LK	
D817	8-719-911-19	DIODE 1SS119		Q505	8-729-011-07	TRANSISTOR 2SC4763 (LBSONY)	
* D901	8-719-911-19	DIODE 1SS119			4-382-854-01	SCREW (M3X8), P, SW (+); Q505	
D902	8-719-109-96	DIODE RD6.8ESB1		Q506	8-729-019-71	TRANSISTOR 2SK1916-53-F50	
D903	8-719-302-43	DIODE EL1Z			4-382-854-01	SCREW (M3X8), P, SW (+); Q506	
D906	8-719-980-78	DIODE ERA83-006		Q508	8-729-140-96	TRANSISTOR 2SD774-34	
* D907	8-719-911-19	DIODE 1SS119		Q509	8-729-140-93	TRANSISTOR 2SB733-34	
D908	8-719-911-19	DIODE 1SS119		Q510	8-729-119-76	TRANSISTOR 2SA1175-HFE	
D1601	8-719-911-19	DIODE 1SS119		Q511	8-729-119-76	TRANSISTOR 2SA1175-HFE	
D1670	8-719-109-84	DIODE RD5.1ESB1		Q512	8-729-119-76	TRANSISTOR 2SA1175-HFE	
D1671	8-719-911-19	DIODE 1SS119					
D1672	8-719-109-84	DIODE RD5.1ESB1		Q513	8-729-119-78	TRANSISTOR 2SC2785-HFE	
D1810	8-719-908-03	DIODE GP08D		Q514	8-729-119-78	TRANSISTOR 2SC2785-HFE	
D1811	8-719-908-03	DIODE GP08D		Q515	8-729-119-76	TRANSISTOR 2SA1175-HFE	
		<FERRITE BEAD>		Q516	8-729-011-06	TRANSISTOR 2SC3840K	
FB501	1-410-397-21	FERRITE BEAD INDUCTOR 1.1UH		Q517	8-729-119-76	TRANSISTOR 2SA1175-HFE	
		<IC>		Q518	8-729-119-78	TRANSISTOR 2SC2785-HFE	
IC501	1-809-845-11	MODULE, PROTECTOR PM-30		Q519	8-729-119-78	TRANSISTOR 2SC2785-HFE	
IC502	8-759-103-93	IC UPC393C		Q520	8-729-119-78	TRANSISTOR 2SC2785-HFE	
IC503	8-759-103-93	IC UPC393C		Q521	8-729-119-78	TRANSISTOR 2SC2785-HFE	
IC504	8-759-192-71	IC STV9379		Q522	8-729-119-78	TRANSISTOR 2SC2785-HFE	
	4-382-854-01	SCREW (M3X8), P, SW (+); IC504		Q523	8-729-119-76	TRANSISTOR 2SA1175-HFE	
IC505	8-759-168-24	IC TA8200AH		Q530	8-729-119-76	TRANSISTOR 2SA1175-HFE	
IC506	8-759-231-58	IC TA7812S		Q531	8-729-119-76	TRANSISTOR 2SA1175-HFE	
IC507	8-759-231-58	IC TA7812S		Q532	8-729-119-78	TRANSISTOR 2SC2785-HFE	
IC508	8-759-231-58	IC TA7812S		Q801	8-729-900-89	TRANSISTOR DTC144ES	
IC510	8-759-231-53	IC TA7805S		Q802	8-729-119-76	TRANSISTOR 2SA1175-HFE	
IC511	8-749-920-58	IC SI-3090CA		Q803	8-729-119-78	TRANSISTOR 2SC2785-HFE	
IC512	1-809-054-11	MODULE, PROTECTOR PM-21		Q804	8-729-119-78	TRANSISTOR 2SC2785-HFE	
IC802	8-752-052-88	IC CXA1526P		Q805	8-729-140-93	TRANSISTOR 2SB733-34	
IC803	8-759-135-80	IC UPC358C		Q806	8-729-119-78	TRANSISTOR 2SC2785-HFE	
IC901	8-759-135-80	IC UPC358C		Q807	8-729-140-97	TRANSISTOR 2SB734-34	
IC903	8-759-103-93	IC UPC393C		Q808	8-729-119-76	TRANSISTOR 2SA1175-HFE	
IC1601	8-759-083-85	IC LA7856A		Q809	8-729-019-01	TRANSISTOR 2SD2394-EF	
IC1603	8-759-135-80	IC UPC358C		Q810	8-729-140-96	TRANSISTOR 2SD774-34	
IC1604	8-759-135-80	IC UPC358C		Q811	8-729-119-78	TRANSISTOR 2SC2785-HFE	
IC1605	8-759-902-21	IC SN74LS221N		Q901	8-729-119-76	TRANSISTOR 2SA1175-HFE	
		<COIL>		Q902	8-729-119-78	TRANSISTOR 2SC2785-HFE	
L501	1-402-830-11	COIL, CHOKE 68UH		Q903	8-729-119-78	TRANSISTOR 2SC2785-HFE	
L502	1-412-549-31	INDUCTOR 1MMH		Q904	8-729-119-76	TRANSISTOR 2SA1175-HFE	
L503 Δ	1-460-197-11	COIL, FERRITE (PMC)		Q905	8-729-119-76	TRANSISTOR 2SA1175-HFE	
L504	1-459-123-00	COIL, DUST CORE (PAC)		Q906	8-729-119-80	TRANSISTOR 2SC2688-LK	
L506	1-459-104-00	COIL, DUST CORE		Q907	8-729-119-80	TRANSISTOR 2SC2688-LK	
* L508	1-412-519-11	INDUCTOR 3.3UH		Q908	8-729-140-97	TRANSISTOR 2SB734-34	
L509	1-412-519-11	INDUCTOR 3.3UH		Q909	8-729-119-78	TRANSISTOR 2SC2785-HFE	
L510	1-412-531-31	INDUCTOR 33UH		Q910	8-729-119-78	TRANSISTOR 2SC2785-HFE	
L511	1-410-071-11	INDUCTOR 10MMH		Q911	8-729-119-78	TRANSISTOR 2SC2785-HFE	
* L512	1-412-552-31	INDUCTOR 2.2MMH		Q912	8-729-119-76	TRANSISTOR 2SA1175-HFE	
L513	1-412-531-31	INDUCTOR 33UH		Q913	8-729-931-45	TRANSISTOR 1RF614	
L514	1-412-531-31	INDUCTOR 33UH		Q914	8-729-119-76	TRANSISTOR 2SA1175-HFE	
L520	1-412-531-31	INDUCTOR 33UH		Q1604	8-729-119-78	TRANSISTOR 2SC2785-HFE	
L801	1-459-592-11	COIL (WITH CORE) (PMC)		Q1605	8-729-119-78	TRANSISTOR 2SC2785-HFE	
L802	1-459-087-00	COIL, HCC DUST CORE 3.9MMH		Q1606	8-729-119-78	TRANSISTOR 2SC2785-HFE	
L901	1-410-093-11	INDUCTOR 33MMH		Q1670	8-729-119-78	TRANSISTOR 2SC2785-HFE	
L902	1-459-075-00	COIL, DYNAMIC CONVERSION CHOKE		Q1671	8-729-119-76	TRANSISTOR 2SA1175-HFE	
				Q1672	8-729-119-76	TRANSISTOR 2SA1175-HFE	
				Q1673	8-729-900-89	TRANSISTOR DTC144ES	
				Q1674	8-729-900-89	TRANSISTOR DTC144ES	
				Q1675	8-729-119-76	TRANSISTOR 2SA1175-HFE	
				Q1676	8-729-119-78	TRANSISTOR 2SC2785-HFE	

A

Les composants identifiés par
une trame et une marque Δ
sont critiques pour la sécurité.
Ne les remplacer que par une
pièce portant le numéro spécifié.

The components identified by
shading and mark Δ are critical
for safety.
Replace only with part number
specified.

REF. NO.	PART NO.	DESCRIPTION	REMARK	REF. NO.	PART NO.	DESCRIPTION	REMARK
<RESISTOR>							
R522	1-249-411-11	CARBON	330 5% 1/4W	R589	1-249-441-11	CARBON	100K 5% 1/4W
R523	1-249-423-11	CARBON	3.3K 5% 1/4W	R590	1-247-901-11	CARBON	820K 5% 1/4W
R524	1-260-331-11	CARBON	1.8K 5% 1/2W	R591	1-215-881-11	METAL OXIDE	15 5% 2W F
R525	1-216-480-11	METAL OXIDE	820 5% 3W F	R592	1-260-320-11	CARBON	220 5% 1/2W
R526	1-216-480-11	METAL OXIDE	820 5% 3W F	R598	1-215-882-00	METAL OXIDE	22 5% 2W F
R527	1-249-401-11	CARBON	47 5% 1/4W	R599	1-249-437-11	CARBON	47K 5% 1/4W
R528	1-249-397-11	CARBON	22 5% 1/4W F	R600	1-249-429-11	CARBON	10K 5% 1/4W
R529	1-249-393-11	CARBON	10 5% 1/4W F	R601	1-249-437-11	CARBON	47K 5% 1/4W
R530	1-249-393-11	CARBON	10 5% 1/4W F	R602	1-215-453-00	METAL	22K 1% 1/4W
R531	1-249-425-11	CARBON	4.7K 5% 1/4W	R604	1-215-455-00	METAL	27K 1% 1/4W
R532	1-247-887-00	CARBON	220K 5% 1/4W	R605	1-216-370-11	METAL OXIDE	1.2 5% 2W F
R533	1-215-878-00	METAL OXIDE	33K 5% 1W F	R606	1-215-913-11	METAL OXIDE	220 5% 3W F
R534	1-249-437-11	CARBON	47K 5% 1/4W	R607	1-249-383-11	CARBON	1.5 5% 1/4W F
R535	1-215-473-00	METAL	150K 1% 1/4W	R610	1-249-432-11	CARBON	18K 5% 1/4W
R536	1-215-445-00	METAL	10K 1% 1/4W	R611	1-249-432-11	CARBON	18K 5% 1/4W
R537	1-215-463-00	METAL	56K 1% 1/4W	R612	1-249-425-11	CARBON	4.7K 5% 1/4W
R538	1-215-449-00	METAL	15K 1% 1/4W	R613	1-249-437-11	CARBON	47K 5% 1/4W
R539	1-249-425-11	CARBON	4.7K 5% 1/4W	R614	1-249-421-11	CARBON	2.2K 5% 1/4W
R542	1-249-434-11	CARBON	27K 5% 1/4W	R615	1-249-409-11	CARBON	220 5% 1/4W
R545	1-247-889-00	CARBON	270K 5% 1/4W	R620	1-249-424-11	CARBON	3.9K 5% 1/4W
R546	1-249-441-11	CARBON	100K 5% 1/4W	R621	1-249-424-11	CARBON	3.9K 5% 1/4W
R547	1-249-441-11	CARBON	100K 5% 1/4W	R622	1-249-410-11	CARBON	270 5% 1/4W
R548	1-215-449-00	METAL	15K 1% 1/4W	R623	1-249-425-11	CARBON	4.7K 5% 1/4W
R549	1-249-441-11	CARBON	100K 5% 1/4W	R624	1-249-425-11	CARBON	4.7K 5% 1/4W
R550	1-215-441-00	METAL	6.8K 1% 1/4W	R625	1-249-410-11	CARBON	270 5% 1/4W
R551	1-215-457-00	METAL	33K 1% 1/4W	R626	1-249-433-11	CARBON	22K 5% 1/4W
R552	1-215-465-00	METAL	68K 1% 1/4W	R627	1-249-433-11	CARBON	22K 5% 1/4W
R553	1-247-903-00	CARBON	1M 5% 1/4W	R628	1-249-441-11	CARBON	100K 5% 1/4W
R554	1-249-419-11	CARBON	1.5K 5% 1/4W	R629	1-247-883-00	CARBON	150K 5% 1/4W
R555	1-249-438-11	CARBON	56K 5% 1/4W	R630	1-249-398-11	CARBON	27 5% 1/4W F
R556	1-249-423-11	CARBON	3.3K 5% 1/4W	R631	1-249-441-11	CARBON	100K 5% 1/4W
R557	1-249-435-11	CARBON	33K 5% 1/4W	R632	1-249-385-11	CARBON	2.2 5% 1/4W F
R558	1-249-433-11	CARBON	22K 5% 1/4W	R633	1-249-385-11	CARBON	2.2 5% 1/4W F
R559	1-249-417-11	CARBON	1K 5% 1/4W	R634	1-215-888-00	METAL OXIDE	220 5% 2W F
R560	1-249-429-11	CARBON	10K 5% 1/4W	R635	1-215-444-00	METAL	9.1K 1% 1/4W
R561	1-249-437-11	CARBON	47K 5% 1/4W	R636	1-215-425-00	METAL	1.5K 1% 1/4W
R562	1-249-437-11	CARBON	47K 5% 1/4W	R637	1-249-429-11	CARBON	10K 5% 1/4W
R563	1-249-441-11	CARBON	100K 5% 1/4W	R638	1-249-417-11	CARBON	1K 5% 1/4W
R564	1-249-415-11	CARBON	680 5% 1/4W	R650	1-216-382-11	METAL OXIDE	0.27 5% 3W F
R565	1-215-450-00	METAL	16K 1% 1/4W	R651	1-249-417-11	CARBON	1K 5% 1/4W F
R566	1-249-410-11	CARBON	270 5% 1/4W	R652	1-249-405-11	CARBON	100 5% 1/4W F
R567	1-249-402-11	CARBON	56 5% 1/4W	R670	1-249-409-11	CARBON	220 5% 1/4W
R568	1-249-411-11	CARBON	330 5% 1/4W	R671	1-249-429-11	CARBON	10K 5% 1/4W
R569	1-249-441-11	CARBON	100K 5% 1/4W	R680	1-249-426-11	CARBON	5.6K 5% 1/4W
R570	1-249-441-11	CARBON	100K 5% 1/4W	R682	1-249-409-11	CARBON	220 5% 1/4W F
R571	1-249-441-11	CARBON	100K 5% 1/4W	R683	1-249-429-11	CARBON	10K 5% 1/4W
R572	1-216-439-00	METAL OXIDE	12K 5% 1W F	R684	1-249-425-11	CARBON	4.7K 5% 1/4W
R573	1-216-459-00	METAL OXIDE	2.7K 5% 2W F	R685	1-249-425-11	CARBON	4.7K 5% 1/4W
R574	1-216-459-00	METAL OXIDE	2.7K 5% 2W F	R686	1-249-423-11	CARBON	3.3K 5% 1/4W
R575	1-202-826-00	SOLID	4.7K 20% 1/2W	R687	1-247-807-31	CARBON	100 5% 1/4W
R576	1-259-882-11	CARBON	3.3M 5% 1/4W	R688	1-216-455-11	METAL OXIDE	560 5% 2W F
R577	1-249-443-11	CARBON	0.47 5% 1/4W F	R689	1-215-471-00	METAL	120K 1% 1/4W
R578	1-249-443-11	CARBON	0.47 5% 1/4W F	R801	1-249-409-11	CARBON	220 5% 1/4W
R580	1-249-496-11	CARBON	100K 5% 1/2W	R802	1-249-409-11	CARBON	220 5% 1/4W
R581 Δ	1-249-417-11	CARBON	1K 5% 1/4W	R804	1-247-891-00	CARBON	330K 5% 1/4W
R582	1-249-417-11	CARBON	1K 5% 1/4W	R808	1-215-463-00	METAL	56K 1% 1/4W
R583 Δ	1-249-425-11	CARBON	4.7K 5% 1/4W	R809	1-249-423-11	CARBON	3.3K 5% 1/4W
R584	1-249-425-11	CARBON	4.7K 5% 1/4W	R810	1-249-413-11	CARBON	470 5% 1/4W
R585	1-249-425-11	CARBON	4.7K 5% 1/4W	R811	1-249-434-11	CARBON	27K 5% 1/4W
R586	1-247-903-00	CARBON	1M 5% 1/4W	R812	1-249-438-11	CARBON	56K 5% 1/4W
R587	1-249-440-11	CARBON	82K 5% 1/4W	R813	1-249-417-11	CARBON	1K 5% 1/4W
R588	1-215-869-11	METAL OXIDE	1K 5% 1W F	R814	1-249-429-11	CARBON	10K 5% 1/4W
				R815	1-249-427-11	CARBON	6.8K 5% 1/4W
				R816	1-249-425-11	CARBON	4.7K 5% 1/4W

• The components identified by Δ in this manual have been carefully factory-selected for each set in order to satisfy regulations regarding X-ray radiation. Should replacement be required, replace only with the value originally used.



REF. NO.	PART NO.	DESCRIPTION	REMARK	REF. NO.	PART NO.	DESCRIPTION	REMARK
R817	1-249-422-11	CARBON	2.7K 5% 1/4W	R938	1-247-807-31	CARBON	100 5% 1/4W
R818	1-249-417-11	CARBON	1K 5% 1/4W	R939	1-249-405-11	CARBON	100 5% 1/4W F
R820	1-249-417-11	CARBON	1K 5% 1/4W	R940	1-249-405-11	CARBON	100 5% 1/4W F
R821	1-216-379-11	METAL OXIDE	6.8 5% 2W F	R941	1-247-807-31	CARBON	100 5% 1/4W
R822	1-249-423-11	CARBON	3.3K 5% 1/4W	R944	1-249-432-11	CARBON	18K 5% 1/4W
R824	1-249-419-11	CARBON	1.5K 5% 1/4W F	R945	1-247-895-00	CARBON	470K 5% 1/4W
R825	1-215-857-11	METAL OXIDE	10 5% 1W F	R946	1-249-425-11	CARBON	4.7K 5% 1/4W
R826	1-249-404-00	CARBON	82 5% 1/4W	R947	1-249-419-11	CARBON	1.5K 5% 1/4W F
R827	1-216-438-11	METAL OXIDE	8.2K 5% 1W F	R948	1-249-435-11	CARBON	33K 5% 1/4W
R828	1-249-441-11	CARBON	100K 5% 1/4W	R950	1-249-425-11	CARBON	4.7K 5% 1/4W
R829	1-249-414-11	CARBON	560 5% 1/4W	R952	1-247-807-31	CARBON	100 5% 1/4W
R830	1-249-411-11	CARBON	330 5% 1/4W	R953	1-247-889-00	CARBON	270K 5% 1/4W
R831	1-249-426-11	CARBON	5.6K 5% 1/4W	R954	1-247-889-00	CARBON	270K 5% 1/4W
R832	1-215-864-00	METAL OXIDE	150 5% 1W F	R956	1-249-433-11	CARBON	22K 5% 1/4W
R833	1-249-421-11	CARBON	2.2K 5% 1/4W	R1601	1-215-461-00	METAL	47K 1% 1/4W
R834	1-249-433-11	CARBON	22K 5% 1/4W	R1602	1-249-429-11	CARBON	10K 5% 1/4W
R835	1-249-393-11	CARBON	10 5% 1/4W	R1603	1-215-451-00	METAL	18K 1% 1/4W
R836	1-249-435-11	CARBON	33K 5% 1/4W	R1604	1-215-445-00	METAL	10K 1% 1/4W
R837	1-249-435-11	CARBON	33K 5% 1/4W	R1605	1-215-421-00	METAL	1K 1% 1/4W
R838	1-215-857-11	METAL OXIDE	10 5% 1W F	R1606	1-249-423-11	CARBON	3.3K 5% 1/4W
R839	1-249-410-11	CARBON	270 5% 1/4W	R1607	1-249-436-11	CARBON	39K 5% 1/4W
R840	1-249-429-11	CARBON	10K 5% 1/4W	R1608	1-215-445-00	METAL	10K 1% 1/4W
R841	1-249-437-11	CARBON	47K 5% 1/4W	R1609	1-215-445-00	METAL	10K 1% 1/4W
R842	1-249-429-11	CARBON	10K 5% 1/4W	R1610	1-249-423-11	CARBON	3.3K 5% 1/4W
R843	1-249-421-11	CARBON	2.2K 5% 1/4W	R1611	1-249-421-11	CARBON	2.2K 5% 1/4W
R844	1-249-421-11	CARBON	2.2K 5% 1/4W	R1612	1-215-467-00	METAL	82K 1% 1/4W
R845	1-249-417-11	CARBON	1K 5% 1/4W	R1613	1-215-469-00	METAL	100K 1% 1/4W
R901	1-249-425-11	CARBON	4.7K 5% 1/4W	R1614	1-249-430-11	CARBON	12K 5% 1/4W
R902	1-249-438-11	CARBON	56K 5% 1/4W	R1615	1-249-431-11	CARBON	15K 5% 1/4W
R903	1-249-429-11	CARBON	10K 5% 1/4W	R1616	1-247-807-31	CARBON	100 5% 1/4W
R904	1-249-429-11	CARBON	10K 5% 1/4W	R1617	1-249-431-11	CARBON	15K 5% 1/4W
R905	1-249-429-11	CARBON	10K 5% 1/4W	R1618	1-249-429-11	CARBON	10K 5% 1/4W
R906	1-249-425-11	CARBON	4.7K 5% 1/4W	R1619	1-249-437-11	CARBON	47K 5% 1/4W
R907	1-249-429-11	CARBON	10K 5% 1/4W	R1622	1-249-428-11	CARBON	8.2K 5% 1/4W
R908	1-249-434-11	CARBON	27K 5% 1/4W	R1623	1-249-427-11	CARBON	6.8K 5% 1/4W
R909	1-215-465-00	METAL	68K 1% 1/4W	R1624	1-249-429-11	CARBON	10K 5% 1/4W
R910	1-215-457-00	METAL	33K 1% 1/4W	R1625	1-249-433-11	CARBON	22K 5% 1/4W
R911	1-249-441-11	CARBON	100K 5% 1/4W	R1626	1-249-440-11	CARBON	82K 5% 1/4W
R912	1-249-429-11	CARBON	10K 5% 1/4W	R1631	1-249-425-11	CARBON	4.7K 5% 1/4W
R913	1-249-425-11	CARBON	4.7K 5% 1/4W	R1635	1-215-437-00	METAL	4.7K 1% 1/4W
R914	1-249-401-11	CARBON	47 5% 1/4W	R1636	1-247-887-00	CARBON	220K 5% 1/4W
R915	1-249-425-11	CARBON	4.7K 5% 1/4W	R1637	1-215-439-00	METAL	5.6K 1% 1/4W
R916	1-249-421-11	CARBON	2.2K 5% 1/4W	R1638	1-215-439-00	METAL	5.6K 1% 1/4W
R917	1-249-439-11	CARBON	68K 5% 1/4W	R1639	1-249-434-11	CARBON	27K 5% 1/4W
R918	1-249-413-11	CARBON	470 5% 1/4W	R1640	1-215-433-00	METAL	3.3K 1% 1/4W
R919	1-249-437-11	CARBON	47K 5% 1/4W	R1641	1-215-437-00	METAL	4.7K 1% 1/4W
R920	1-249-418-11	CARBON	1.2K 5% 1/4W F	R1642	1-249-426-11	CARBON	5.6K 5% 1/4W
R921	1-215-876-00	METAL OXIDE	15K 5% 1W F	R1643	1-215-455-00	METAL	27K 1% 1/4W
R922	1-215-870-11	METAL OXIDE	1.5K 5% 1W F	R1660	1-215-424-00	METAL	1.3K 1% 1/4W
R923	1-249-429-11	CARBON	10K 5% 1/4W	R1661	1-215-451-00	METAL	18K 1% 1/4W
R924	1-249-423-11	CARBON	3.3K 5% 1/4W	R1662	1-249-441-11	CARBON	100K 5% 1/4W
R925	1-249-415-11	CARBON	680 5% 1/4W	R1663	1-249-428-11	CARBON	8.2K 5% 1/4W
R926	1-249-409-11	CARBON	220 5% 1/4W	R1664	1-249-425-11	CARBON	4.7K 5% 1/4W
R927	1-249-429-11	CARBON	10K 5% 1/4W	R1665	1-249-425-11	CARBON	4.7K 5% 1/4W
R928	1-249-421-11	CARBON	2.2K 5% 1/4W	R1666	1-249-429-11	CARBON	10K 5% 1/4W
R929	1-249-429-11	CARBON	10K 5% 1/4W	R1667	1-247-807-31	CARBON	100 5% 1/4W
R930	1-249-434-11	CARBON	27K 5% 1/4W	R1668	1-249-429-11	CARBON	10K 5% 1/4W
R931	1-249-421-11	CARBON	2.2K 5% 1/4W	R1669	1-249-437-11	CARBON	47K 5% 1/4W
R933	1-249-421-11	CARBON	2.2K 5% 1/4W	R1670	1-249-429-11	CARBON	10K 5% 1/4W
R934	1-249-439-11	CARBON	68K 5% 1/4W	R1671	1-249-429-11	CARBON	10K 5% 1/4W
R935	1-249-429-11	CARBON	10K 5% 1/4W	R1672	1-249-433-11	CARBON	22K 5% 1/4W
R936	1-249-429-11	CARBON	10K 5% 1/4W	R1673	1-215-445-00	METAL	10K 1% 1/4W
R937	1-249-421-11	CARBON	2.2K 5% 1/4W	R1674	1-249-421-11	CARBON	2.2K 5% 1/4W



Les composants identifiés par une trame et une marque Δ sont critiques pour la sécurité. Ne les remplacer que par une pièce portant le numéro spécifique.

The components identified by shading and mark Δ are critical for safety. Replace only with part number specified.

REF. NO.	PART NO.	DESCRIPTION	REMARK	REF. NO.	PART NO.	DESCRIPTION	REMARK
R1675	1-249-429-11	CARBON	10K 5% 1/4W	C805	1-137-399-11	FILM 0.1MF 5%	50V
R1676	1-215-426-00	METAL	1.6K 1% 1/4W	C806	1-163-035-00	CERAMIC CHIP 0.047MF	50V
R1677	1-215-445-00	METAL	10K 1% 1/4W	C807	1-163-009-11	CERAMIC CHIP 0.001MF	10% 50V
R1678	1-215-465-00	METAL	68K 1% 1/4W	C808	1-163-035-00	CERAMIC CHIP 0.047MF	50V
R1680	1-249-417-11	CARBON	1K 5% 1/4W	C809	1-163-035-00	CERAMIC CHIP 0.047MF	50V
R1681	1-249-422-11	CARBON	2.7K 5% 1/4W	C810	1-126-933-11	ELECT 100MF	20% 10V
R1682	1-249-441-11	CARBON	100K 5% 1/4W	C811	1-163-035-00	CERAMIC CHIP 0.047MF	50V
R1683	1-215-449-00	METAL	15K 1% 1/4W	C812	1-163-035-00	CERAMIC CHIP 0.047MF	50V
R1684	1-249-423-11	CARBON	3.3K 5% 1/4W	C814	1-163-239-11	CERAMIC CHIP 33PF	5% 50V
R1685	1-215-428-00	METAL	2K 1% 1/4W	C815	1-163-239-11	CERAMIC CHIP 33PF	5% 50V
R1686	1-215-451-00	METAL	18K 1% 1/4W	C816	1-124-925-11	ELECT 2.2MF	20% 50V
R1687	1-215-451-00	METAL	18K 1% 1/4W	C817	1-164-232-11	CERAMIC CHIP 0.01MF	10% 50V
R1688	1-215-442-00	METAL	7.5K 1% 1/4W	<CONNECTOR>			
R1690	1-249-431-11	CARBON	15K 5% 1/4W	CN801	1-573-965-21	PIN, CONNECTOR (PC BOARD)	50P
R1699	1-215-449-00	METAL	15K 1% 1/4W	CN802	*1-564-520-11	PLUG, CONNECTOR 5P	
R1832	1-215-890-11	METAL OXIDE	470 5% 2W F	CN803	1-564-523-11	PLUG, CONNECTOR 8P	
R1833	1-249-389-11	CARBON	4.7 5% 1/4W F	<DIODE>			
R1834	1-215-883-11	METAL OXIDE	33 5% 2W F	D801	8-719-404-46	DIODE MA110	
	1-216-361-00	METAL OXIDE	0.22 5% 2W F	D802	8-719-404-46	DIODE MA110	
			(PVM-2950Q/2950QM(AEP))	D803	8-719-404-46	DIODE MA110	
			(PVM-2950QM(AUS))	D804	8-719-404-46	DIODE MA110	
R1835	1-215-889-00	METAL OXIDE	330 5% 2W F	D805	8-719-404-46	DIODE MA110	
	1-216-886-11	METAL OXIDE	100 5% 2W F	D806	8-719-404-46	DIODE MA110	
			(PVM-2950Q/2950QM(AEP))	D807	8-719-404-46	DIODE MA110	
			(PVM-2950QM(AUS))	D808	8-719-404-46	DIODE MA110	
R1836	1-215-887-00	METAL OXIDE	150 5% 2W F	D809	8-719-404-46	DIODE MA110	
	1-215-889-00	METAL OXIDE	330 5% 2W F	D810	8-719-404-46	DIODE MA110	
			(PVM-2950Q/2950QM(AEP))	D811	8-719-404-46	DIODE MA110	
			(PVM-2950QM(AUS))	D812	8-719-404-46	DIODE MA110	
R1837	1-215-909-11	METAL OXIDE	47 5% 3W F	D813	8-719-404-46	DIODE MA110	
				D814	8-719-404-46	DIODE MA110	
<VARIABLE RESISTOR>				<IC>			
RV1601	1-228-996-00	RES, ADJ, METAL GLAZE	47K	IC801	8-759-261-31	IC HD6473256P10-PVM1	
RV1602	1-228-993-00	RES, ADJ, METAL GLAZE	4.7K	IC802	8-759-925-74	IC SN74HCO4ANS	
RV1603	1-228-994-00	RES, ADJ, METAL GLAZE	10K	IC803	8-759-083-63	IC UPD6453GT-625-E1	
<SPARK GAP>				IC804	8-759-162-80	IC MM1170BFB	
SG501	1-519-422-11	GAP, SPARK		IC805	8-759-032-26	IC MC74HC125AF	
<TRANSFORMER>				IC806	8-759-156-54	IC X25040S1	
T501	1-437-217-11	TRANSFORMER, HORIZONTAL DRIVE		<COIL>			
T502	Δ 1-460-199-11	TRANSFORMER (HLT)		L801	1-408-421-00	INDUCTOR 100UH	
T503	1-424-584-11	TRANSFORMER, DYNAMIC FOCUS		L802	1-408-421-00	INDUCTOR 100UH	
T504	Δ X-4032-250-1	TRANSFORMER ASSY, FLYBACK		L803	1-410-476-11	INDUCTOR 33UH	
T1801	1-423-622-11	TRANSFORMER, FERRITE (VPOT)		<RESISTOR>			
<THERMISTOR>				R801	1-216-089-91	METAL GLAZE 47K 5%	1/10W
TH501	1-807-925-11	THERMISTOR		R802	1-216-089-91	METAL GLAZE 47K 5%	1/10W
*****				R805	1-216-089-91	METAL GLAZE 47K 5%	1/10W
*A-1301-950-A	M BOARD, COMPLETE			R806	1-216-073-00	METAL GLAZE 10K 5%	1/10W
	*****			R807	1-216-073-00	METAL GLAZE 10K 5%	1/10W
*1-526-950-11	SOCKET, IC 64P			R808	1-216-073-00	METAL GLAZE 10K 5%	1/10W
<CAPACITOR>				R809	1-216-073-00	METAL GLAZE 10K 5%	1/10W
C801	1-126-933-11	ELECT 100MF	20% 10V	R810	1-216-073-00	METAL GLAZE 10K 5%	1/10W
C802	1-163-035-00	CERAMIC CHIP 0.047MF		R811	1-216-073-00	METAL GLAZE 10K 5%	1/10W
C803	1-163-097-00	CERAMIC CHIP 15PF	5% 50V	R812	1-216-049-00	METAL GLAZE 1K 5%	1/10W
C804	1-163-097-00	CERAMIC CHIP 15PF	5% 50V				



REF. NO.	PART NO.	DESCRIPTION	REMARK
R813	1-216-049-00	METAL GLAZE 1K 5% 1/10W	
R814	1-216-049-00	METAL GLAZE 1K 5% 1/10W	
R815	1-216-049-00	METAL GLAZE 1K 5% 1/10W	
R816	1-216-025-00	METAL GLAZE 100 5% 1/10W	
R817	1-216-049-00	METAL GLAZE 1K 5% 1/10W	
R818	1-216-049-00	METAL GLAZE 1K 5% 1/10W	
R819	1-216-049-00	METAL GLAZE 1K 5% 1/10W	
R821	1-216-049-00	METAL GLAZE 1K 5% 1/10W	
R822	1-216-049-00	METAL GLAZE 1K 5% 1/10W	
R823	1-216-025-00	METAL GLAZE 100 5% 1/10W	
R824	1-216-049-00	METAL GLAZE 1K 5% 1/10W	
R825	1-216-049-00	METAL GLAZE 1K 5% 1/10W	
R826	1-216-033-00	METAL GLAZE 220 5% 1/10W	
R827	1-216-049-00	METAL GLAZE 1K 5% 1/10W	
R828	1-216-049-00	METAL GLAZE 1K 5% 1/10W	
R829	1-216-033-00	METAL GLAZE 220 5% 1/10W	
R830	1-216-033-00	METAL GLAZE 220 5% 1/10W	
R831	1-216-089-91	METAL GLAZE 47K 5% 1/10W	
R832	1-216-089-91	METAL GLAZE 47K 5% 1/10W	
R833	1-216-089-91	METAL GLAZE 47K 5% 1/10W	
R834	1-216-049-00	METAL GLAZE 1K 5% 1/10W	
R835	1-216-049-00	METAL GLAZE 1K 5% 1/10W	
R836	1-216-073-00	METAL GLAZE 10K 5% 1/10W	
R837	1-216-049-00	METAL GLAZE 1K 5% 1/10W	
R838	1-216-025-00	METAL GLAZE 100 5% 1/10W	
R839	1-216-025-00	METAL GLAZE 100 5% 1/10W	
R840	1-216-025-00	METAL GLAZE 100 5% 1/10W	
R841	1-216-025-00	METAL GLAZE 100 5% 1/10W	
R842	1-216-073-00	METAL GLAZE 10K 5% 1/10W	
R843	1-216-073-00	METAL GLAZE 10K 5% 1/10W	
R844	1-216-033-00	METAL GLAZE 220 5% 1/10W	
R845	1-216-033-00	METAL GLAZE 220 5% 1/10W	
R846	1-216-067-00	METAL GLAZE 5.6K 5% 1/10W	
R848	1-216-025-00	METAL GLAZE 100 5% 1/10W	
R849	1-216-033-00	METAL GLAZE 220 5% 1/10W	
R850	1-216-033-00	METAL GLAZE 220 5% 1/10W	
R851	1-216-033-00	METAL GLAZE 220 5% 1/10W	
R852	1-216-025-00	METAL GLAZE 100 5% 1/10W	
R853	1-216-049-00	METAL GLAZE 1K 5% 1/10W	
R854	1-216-065-00	METAL GLAZE 4.7K 5% 1/10W	
R855	1-216-065-00	METAL GLAZE 4.7K 5% 1/10W	
R856	1-216-073-00	METAL GLAZE 10K 5% 1/10W	
<CRYSTAL>			
X801	1-760-040-11	VIBRATOR, CRYSTAL	

*A-1341-764-A	DX BOARD, COMPLETE *****		
<CAPACITOR>			
C1501	1-163-031-11	CERAMIC CHIP 0.01MF	50V
C1502	1-163-031-11	CERAMIC CHIP 0.01MF	50V
C1503	1-163-031-11	CERAMIC CHIP 0.01MF	50V
C1504	1-164-161-11	CERAMIC CHIP 0.0022MF	10% 50V
C1505	1-164-161-11	CERAMIC CHIP 0.0022MF	10% 50V
C1506	1-164-161-11	CERAMIC CHIP 0.0022MF	10% 50V
C1507	1-164-232-11	CERAMIC CHIP 0.01MF	10% 50V
C1508	1-136-171-00	FILM 0.33MF	5% 50V
C1509	1-164-161-11	CERAMIC CHIP 0.0022MF	10% 50V
C1510	1-163-011-11	CERAMIC CHIP 0.0015MF	10% 50V

REF. NO.	PART NO.	DESCRIPTION	REMARK
C1511	1-163-011-11	CERAMIC CHIP 0.0015MF	10% 50V
C1512	1-164-004-11	CERAMIC CHIP 0.1MF	10% 25V
C1513	1-164-161-11	CERAMIC CHIP 0.0022MF	10% 50V
C1515	1-163-031-11	CERAMIC CHIP 0.01MF	50V
C1517	1-163-031-11	CERAMIC CHIP 0.01MF	50V
C1518	1-164-004-11	CERAMIC CHIP 0.1MF	10% 25V
C1519	1-163-009-11	CERAMIC CHIP 0.001MF	10% 50V
C1520	1-163-009-11	CERAMIC CHIP 0.001MF	10% 50V
C1521	1-164-161-11	CERAMIC CHIP 0.0022MF	10% 50V
C1522	1-136-171-00	FILM 0.33MF	5% 50V
C1523	1-164-161-11	CERAMIC CHIP 0.0022MF	10% 50V
C1524	1-163-011-11	CERAMIC CHIP 0.0015MF	10% 50V
C1525	1-163-011-11	CERAMIC CHIP 0.0015MF	10% 50V
C1526	1-164-004-11	CERAMIC CHIP 0.1MF	10% 25V
C1528	1-163-031-11	CERAMIC CHIP 0.01MF	50V
C1529	1-163-031-11	CERAMIC CHIP 0.01MF	50V
C1534	1-163-031-11	CERAMIC CHIP 0.01MF	50V
C1537	1-163-031-11	CERAMIC CHIP 0.01MF	50V
C1538	1-163-031-11	CERAMIC CHIP 0.01MF	50V
C1539	1-104-665-11	ELECT 100MF	20% 25V
C1540	1-104-665-11	ELECT 100MF	20% 25V
C1541	1-163-031-11	CERAMIC CHIP 0.01MF	50V
C1542	1-163-031-11	CERAMIC CHIP 0.01MF	50V
C1543	1-163-031-11	CERAMIC CHIP 0.01MF	50V
C1545	1-124-927-11	ELECT 4.7MF	20% 50V
C1550	1-136-177-00	FILM 1MF	5% 50V
C1551	1-126-157-11	ELECT 10MF	20% 16V
C1552	1-136-159-00	FILM 0.033MF	5% 50V
C1590	1-162-638-11	CERAMIC CHIP 1MF	16V
C1591	1-162-638-11	CERAMIC CHIP 1MF	16V
C1592	1-164-004-11	CERAMIC CHIP 0.1MF	10% 25V
<CONNECTOR>			
CN1501	1-573-965-21	PIN, CONNECTOR (PC BOARD) 50P	
<DIODE>			
D1501	8-719-404-46	DIODE MA110	
D1502	8-719-037-03	DIODE RD6.8SB1-T1	
D1505	8-719-404-46	DIODE MA110	
D1506	8-719-404-46	DIODE MA110	
D1507	8-719-404-46	DIODE MA110	
D1508	8-719-404-46	DIODE MA110	
D1590	8-719-033-52	DIODE RD5.1SB1-T1	
D1591	8-719-404-46	DIODE MA110	
<IC>			
IC1501	8-752-347-92	IC CXD2018Q	
IC1502	8-752-347-92	IC CXD2018Q	
IC1503	8-759-970-89	IC BA10358F	
IC1504	8-759-970-89	IC BA10358F	
IC1505	8-759-970-89	IC BA10358F	
IC1506	8-752-058-68	IC CXA1315M	
IC1507	8-759-032-16	IC MC74HC08AF-T2	
IC1508	8-759-032-16	IC MC74HC08AF-T2	
IC1509	8-759-925-80	IC SN74HC14ANS	
IC1511	8-759-032-20	IC MC74HC32AF	
IC1514	8-759-236-47	IC TC74HC164AF (EL)	
IC1516	8-759-236-47	IC TC74HC164AF (EL)	
IC1518	8-759-970-89	IC BA10358F	
IC1590	8-759-970-89	IC BA10358F	

DX G1 G (PVM-2950Q)

Les composants identifiés par une trame et une marque Δ sont critiques pour la sécurité. Ne les remplacer que par une pièce portant le numéro spécifique.

The components identified by shading and mark Δ are critical for safety. Replace only with part number specified.

REF. NO.	PART NO.	DESCRIPTION	REMARK
<COIL>			
L1501	1-408-409-00	INDUCTOR 10UH	
L1502	1-408-409-00	INDUCTOR 10UH	
L1503	1-408-409-00	INDUCTOR 10UH	
L1504	1-408-409-00	INDUCTOR 10UH	
<TRANSISTOR>			
Q1501	8-729-120-28	TRANSISTOR 2SC1623-L5L6	
Q1502	8-729-120-28	TRANSISTOR 2SC1623-L5L6	
Q1503	8-729-120-28	TRANSISTOR 2SC1623-L5L6	
Q1504	8-729-120-28	TRANSISTOR 2SC1623-L5L6	
Q1590	8-729-216-22	TRANSISTOR 2SA1162-G	
Q1591	8-729-120-28	TRANSISTOR 2SC1623-L5L6	
<RESISTOR>			
R1501	1-216-075-00	METAL GLAZE 12K 5% 1/10W	
R1502	1-216-091-00	METAL GLAZE 56K 5% 1/10W	
R1503	1-216-065-00	METAL GLAZE 4.7K 5% 1/10W	
R1504	1-216-065-00	METAL GLAZE 4.7K 5% 1/10W	
R1505	1-216-073-00	METAL GLAZE 10K 5% 1/10W	
R1506	1-216-085-00	METAL GLAZE 33K 5% 1/10W	
R1507	1-216-085-00	METAL GLAZE 33K 5% 1/10W	
R1508	1-216-109-00	METAL GLAZE 330K 5% 1/10W	
R1509	1-216-049-00	METAL GLAZE 1K 5% 1/10W	
R1510	1-216-049-00	METAL GLAZE 1K 5% 1/10W	
R1512	1-216-049-00	METAL GLAZE 1K 5% 1/10W	
R1513	1-216-073-00	METAL GLAZE 10K 5% 1/10W	
R1514	1-216-075-00	METAL GLAZE 12K 5% 1/10W	
R1515	1-216-091-00	METAL GLAZE 56K 5% 1/10W	
R1517	1-216-065-00	METAL GLAZE 4.7K 5% 1/10W	
R1518	1-216-073-00	METAL GLAZE 10K 5% 1/10W	
R1519	1-216-085-00	METAL GLAZE 33K 5% 1/10W	
R1520	1-216-085-00	METAL GLAZE 33K 5% 1/10W	
R1521	1-216-109-00	METAL GLAZE 330K 5% 1/10W	
R1522	1-216-065-00	METAL GLAZE 4.7K 5% 1/10W	
R1523	1-216-065-00	METAL GLAZE 4.7K 5% 1/10W	
R1524	1-216-065-00	METAL GLAZE 4.7K 5% 1/10W	
R1525	1-216-071-00	METAL GLAZE 8.2K 5% 1/10W	
R1526	1-216-073-00	METAL GLAZE 10K 5% 1/10W	
R1527	1-216-073-00	METAL GLAZE 10K 5% 1/10W	
R1528	1-216-083-00	METAL GLAZE 27K 5% 1/10W	
R1529	1-216-047-00	METAL GLAZE 820 5% 1/10W	
R1530	1-216-051-00	METAL GLAZE 1.2K 5% 1/10W	
R1532	1-216-055-00	METAL GLAZE 1.8K 5% 1/10W	
R1533	1-216-057-00	METAL GLAZE 2.2K 5% 1/10W	
R1534	1-216-049-00	METAL GLAZE 1K 5% 1/10W	
R1535	1-216-071-00	METAL GLAZE 8.2K 5% 1/10W	
R1536	1-216-049-00	METAL GLAZE 1K 5% 1/10W	
R1539	1-216-057-00	METAL GLAZE 2.2K 5% 1/10W	
R1541	1-216-073-00	METAL GLAZE 10K 5% 1/10W	
R1542	1-216-073-00	METAL GLAZE 10K 5% 1/10W	
R1547	1-216-059-00	METAL GLAZE 2.7K 5% 1/10W	
R1548	1-216-053-00	METAL GLAZE 1.5K 5% 1/10W	
R1549	1-216-049-00	METAL GLAZE 1K 5% 1/10W	
R1550	1-216-025-00	METAL GLAZE 100 5% 1/10W	
R1551	1-216-059-00	METAL GLAZE 2.7K 5% 1/10W	
R1552	1-216-065-00	METAL GLAZE 4.7K 5% 1/10W	
R1553	1-216-073-00	METAL GLAZE 10K 5% 1/10W	
R1554	1-216-059-00	METAL GLAZE 2.7K 5% 1/10W	
R1560	1-216-065-00	METAL GLAZE 4.7K 5% 1/10W	

REF. NO.	PART NO.	DESCRIPTION	REMARK
R1561	1-216-113-00	METAL GLAZE 470K 5% 1/10W	
R1562	1-216-097-00	METAL GLAZE 100K 5% 1/10W	
R1570	1-216-095-00	METAL GLAZE 82K 5% 1/10W	
R1571	1-216-073-00	METAL GLAZE 10K 5% 1/10W	
R1572	1-216-073-00	METAL GLAZE 10K 5% 1/10W	
R1573	1-216-073-00	METAL GLAZE 10K 5% 1/10W	
R1574	1-216-073-00	METAL GLAZE 10K 5% 1/10W	
R1575	1-216-089-91	METAL GLAZE 47K 5% 1/10W	
R1576	1-216-073-00	METAL GLAZE 10K 5% 1/10W	
R1577	1-216-067-00	METAL GLAZE 5.6K 5% 1/10W	
R1578	1-216-097-00	METAL GLAZE 100K 5% 1/10W	
R1579	1-216-073-00	METAL GLAZE 10K 5% 1/10W	
R1590	1-216-105-00	METAL GLAZE 220K 5% 1/10W	
R1591	1-216-063-00	METAL GLAZE 3.9K 5% 1/10W	
R1592	1-216-668-11	METAL CHIP 5.1K 0.50% 1/10W	
R1593	1-216-668-11	METAL CHIP 5.1K 0.50% 1/10W	
R1594	1-216-073-00	METAL GLAZE 10K 5% 1/10W	
R1595	1-216-073-00	METAL GLAZE 10K 5% 1/10W	
R1596	1-216-065-00	METAL GLAZE 4.7K 5% 1/10W	
R1597	1-216-073-00	METAL GLAZE 10K 5% 1/10W	
R1598	1-216-065-00	METAL GLAZE 4.7K 5% 1/10W	

*A-1311-363-A	G1 BOARD, COMPLETE (PVM-2950Q)		

*A-1311-365-A	G1 BOARD, COMPLETE (PVM-2950QM)		

<CAPACITOR>			
C601	Δ 1-162-599-12	CERAMIC 0.0047MF 20% 400V	
<CONNECTOR>			
CN602	*1-508-786-00	PIN, CONNECTOR (5MM PITCH) 2P	
CN603	*1-573-963-11	PIN, CONNECTOR (PC BOARD) 3P	
CN604	*1-573-963-11	PIN, CONNECTOR (PC BOARD) 3P	
CN610	*1-691-134-11	PIN, CONNECTOR (PC BOARD) 2P	
CN611	*1-537-711-11	TAB, FASTEN (PCB)	
<THERMISTOR>			
THP601	Δ 1-809-539-11	THERMISTOR, POSITIVE (PVM-2950Q)	
	Δ 1-809-827-11	THERMISTOR, POSITIVE (PVM-2950QM)	

*A-1316-181-A	G BOARD, COMPLETE (PVM-2950Q)		

	1-533-223-11	CLIP, FUSE	
	4-382-854-11	SCREW (M3X10), P, SW (+)	
<CAPACITOR>			
C602	Δ 1-104-706-11	FILM 0.22MF 20% 250V	
C603	Δ 1-104-706-11	FILM 0.22MF 20% 250V	
C604	Δ 1-162-599-12	CERAMIC 0.0047MF 20% 400V	
C605	Δ 1-162-599-12	CERAMIC 0.0047MF 20% 400V	
C606	1-104-346-11	ELECT 1000MF 200V	
C610	1-136-067-00	FILM 0.0036MF 3% 2KV	
C611	1-106-357-00	MYLAR 0.0039MF 10% 100V	
C612	1-124-927-11	ELECT 4.7MF 20% 50V	
C613	1-126-948-11	ELECT 100MF 20% 35V	
C615	Δ 1-162-599-12	CERAMIC 0.0047MF 20% 400V	

Les composants identifiés par
une trame et une marque Δ
sont critiques pour la securite.
Ne les remplacer que par une
piece portant le numero specifique.

The components identified by
shading and mark Δ are critical
for safety.
Replace only with part number
specified.

G (PVM-2950Q)

G (PVM-2950QM)

REF. NO.	PART NO.	DESCRIPTION	REMARK
R638	1-249-438-11	CARBON 56K 5% 1/4W	
R642	1-216-422-11	METAL OXIDE 18 5% 1W	F
R643	1-249-424-11	CARBON 3.9K 5% 1/4W	
R644	1-249-429-11	CARBON 10K 5% 1/4W	
R645	1-249-433-11	CARBON 22K 5% 1/4W	
R646	1-249-424-11	CARBON 3.9K 5% 1/4W	
R647	1-249-429-11	CARBON 10K 5% 1/4W	
R648	1-249-417-11	CARBON 1K 5% 1/4W	
R649	1-247-895-00	CARBON 470K 5% 1/4W	
R650	1-249-438-11	CARBON 56K 5% 1/4W	
R651	1-249-431-11	CARBON 15K 5% 1/4W	
R652	1-249-425-11	CARBON 4.7K 5% 1/4W	
R653	1-249-437-11	CARBON 47K 5% 1/4W	
R654	1-249-429-11	CARBON 10K 5% 1/4W	
R655	1-249-424-11	CARBON 3.9K 5% 1/4W	
R656	1-249-431-11	CARBON 15K 5% 1/4W	
R660	Δ 1-247-903-00	CARBON 1M 5% 1/4W	
<RELAY>			
RY601	Δ 1-515-738-11	RELAY	
RY602	Δ 1-515-738-11	RELAY	
<TRANSFORMER>			
T601	Δ 1-424-248-11	TRANSFORMER, LINE FILTER	
T602	Δ 1-424-248-11	TRANSFORMER, LINE FILTER	
T603	Δ 1-426-946-11	TRANSFORMER, POWER	
T604	Δ 1-426-943-11	TRANSFORMER, CONVERTER (SRT)	
<VARISTOR>			
VDR601	Δ 1-809-786-11	VARISTOR	

*A-1316-182-A	G BOARD, COMPLETE (PVM-2950QM) *****		
1-533-223-11	CLIP, FUSE		
4-382-854-11	SCREW (M3X10), P, SW (+)		
<CAPACITOR>			
C602	Δ 1-104-706-11	FILM 0.22MF 20% 250V	
C603	Δ 1-104-706-11	FILM 0.22MF 20% 250V	
C604	Δ 1-162-599-12	CERAMIC 0.0047MF 20% 400V	
C605	Δ 1-162-599-12	CERAMIC 0.0047MF 20% 400V	
C607	1-137-485-11	FILM 0.68MF 10% 630V	
C608	1-137-485-11	FILM 0.68MF 10% 630V	
C609	1-136-206-11	FILM 0.033MF 10% 630V	
C610	1-136-539-11	FILM 0.0022MF 3% 2KV	
C611	1-106-357-00	MYLAR 0.0039MF 10% 100V	
C612	1-124-927-11	ELECT 4.7MF 20% 50V	
C613	1-126-949-11	ELECT 220MF 20% 35V	
C614	1-126-233-11	ELECT 22MF 20% 50V	
C615	Δ 1-162-599-12	CERAMIC 0.0047MF 20% 400V	
C616	Δ 1-162-599-12	CERAMIC 0.0047MF 20% 400V	
C618	1-162-115-00	CERAMIC 330PF 10% 2KV	
C620	1-161-754-00	CERAMIC 0.001MF 10% 2KV	
C621	1-125-473-11	ELECT (BLOCK) 1000MF 20% 160V	
C622	1-126-933-11	ELECT 100MF 20% 10V	
C623	1-130-783-00	MYLAR 0.33MF 10% 100V	
C624	1-107-637-11	ELECT 22MF 20% 160V	
C625	1-162-318-11	CERAMIC 0.001MF 10% 500V	

REF. NO.	PART NO.	DESCRIPTION	REMARK
C626	1-104-868-11	ELECT 2200MF 20% 25V	
C627	1-162-318-11	CERAMIC 0.001MF 10% 500V	
C628	1-104-868-11	ELECT 2200MF 20% 25V	
C629	1-162-318-11	CERAMIC 0.001MF 10% 500V	
C630	1-104-877-11	ELECT 2200MF 20% 35V	
C640	1-126-952-11	ELECT 1000MF 20% 35V	
C642	1-126-967-11	ELECT 47MF 20% 50V	
C643	1-126-964-11	ELECT 10MF 20% 50V	
C644	1-126-964-11	ELECT 10MF 20% 50V	
C645	1-126-933-11	ELECT 100MF 20% 10V	
C646	1-126-964-11	ELECT 10MF 20% 50V	
C647	1-126-933-11	ELECT 100MF 20% 16V	
C660	Δ 1-161-742-00	CERAMIC 0.0022MF 20% 400V	
C661	Δ 1-161-742-00	CERAMIC 0.0022MF 20% 400V	
<CONNECTOR>			
CN601	*1-580-843-11	PIN, CONNECTOR (POWER)	
CN605	*1-564-508-11	PLUG, CONNECTOR 5P	
CN606	*1-573-986-11	PIN, CONNECTOR (PC BOARD) 5P	
CN607	*1-564-507-11	PLUG, CONNECTOR 4P	
CN609	*1-691-134-11	PIN, CONNECTOR (PC BOARD) 2P	
<DIODE>			
D601	8-719-510-53	DIODE D4SB60L	
D603	8-719-311-31	DIODE RU-1P	
D604	8-719-979-58	DIODE EGP10D	
D605	8-719-911-19	DIODE 1SS119	
D607	8-719-979-58	DIODE EGP10D	
D620	8-719-029-04	DIODE D5L60	
D621	8-719-045-48	DIODE FML-G12S	
D622	8-719-045-48	DIODE FML-G12S	
D623	8-719-920-67	DIODE ERC91-02	
D625	8-719-911-19	DIODE 1SS119	
D640	8-719-511-40	DIODE S1VB40	
D641	8-719-911-19	DIODE 1SS119	
D643	8-719-911-19	DIODE 1SS119	
D645	8-719-110-36	DIODE RD13ESB2	
D646	8-719-911-19	DIODE 1SS119	
<FUSE>			
F601	Δ 1-576-232-21	FUSE (H.B.C.) (5.0A/250V)	
<FERRITE BEAD>			
FB601	1-410-397-21	FERRITE BEAD INDUCTOR 1.1UH	
FB602	1-410-396-41	FERRITE BEAD INDUCTOR 0.45UH	
FB603	1-410-396-41	FERRITE BEAD INDUCTOR 0.45UH	
FB604	1-410-396-41	FERRITE BEAD INDUCTOR 0.45UH	
FB605	1-410-396-41	FERRITE BEAD INDUCTOR 0.45UH	
FB606	1-410-396-41	FERRITE BEAD INDUCTOR 0.45UH	
FB607	1-410-396-41	FERRITE BEAD INDUCTOR 0.45UH	
FB608	1-410-396-41	FERRITE BEAD INDUCTOR 0.45UH	
FB609	1-410-396-41	FERRITE BEAD INDUCTOR 0.45UH	
FB620	1-410-396-41	FERRITE BEAD INDUCTOR 0.45UH	
FB621	1-410-396-41	FERRITE BEAD INDUCTOR 0.45UH	
FB622	1-410-396-41	FERRITE BEAD INDUCTOR 0.45UH	
FB623	1-410-396-41	FERRITE BEAD INDUCTOR 0.45UH	
<IC>			
IC601	8-749-925-03	IC STR-M6524	
IC620	8-749-010-02	IC STR-S3135	

The components identified by shading and mark Δ are critical for safety.
Replace only with part number specified.

Les composants identifiés par une trame et une marque Δ sont critiques pour la sécurité.
Ne les remplacer que par une pièce portant le numéro spécifié.

G (PVM-2950QM) **C**

REF. NO.	PART NO.	DESCRIPTION	REMARK
IC641	8-759-701-56	IC NJM78M05FA	
<COIL>			
L601	1-459-946-11	COIL, NOISE FILTER	
L620	1-406-663-21	COIL, CHOKE 47UH	
L621	1-412-533-21	INDUCTOR 47UH	
L622	1-412-533-21	INDUCTOR 47UH	
L623	1-412-527-11	INDUCTOR 15UH	
L624	1-412-527-11	INDUCTOR 15UH	
<PHOTO COUPLER>			
PH602	Δ 8-749-923-50	PHOTO COUPLER PC111YS	
<IC LINK>			
PS620	Δ 1-532-686-21	LINK, IC 2.7A	
PS622	Δ 1-532-686-21	LINK, IC 2.7A	
<TRANSISTOR>			
Q601	8-729-119-76	TRANSISTOR 2SA1175-HFE	
Q602	8-729-119-78	TRANSISTOR 2SC2785-HFE	
Q620	8-729-119-78	TRANSISTOR 2SC2785-HFE	
Q621	8-729-119-76	TRANSISTOR 2SA1175-HFE	
Q641	8-729-119-78	TRANSISTOR 2SC2785-HFE	
Q642	8-729-119-78	TRANSISTOR 2SC2785-HFE	
Q643	8-729-140-96	TRANSISTOR 2SD774-34	
<RESISTOR>			
R601	Δ 1-202-719-00	SOLID 1M 20% 1/2W	
R602	1-215-929-11	METAL OXIDE 100K 5% 3W F	
R603	1-216-492-11	METAL OXIDE 82K 5% 3W F	
R604	1-215-929-11	METAL OXIDE 100K 5% 3W F	
R605	1-216-382-11	METAL OXIDE 0.27 5% 3W F	
R606	1-216-383-11	METAL OXIDE 0.33 5% 3W F	
R607	1-249-415-11	CARBON 680 5% 1/4W	
R608	1-249-418-11	CARBON 1.2K 5% 1/4W	
R609	1-249-437-11	CARBON 47K 5% 1/4W F	
R610	1-249-425-11	CARBON 4.7K 5% 1/4W F	
R611	1-249-425-11	CARBON 4.7K 5% 1/4W F	
R613	1-249-417-11	CARBON 1K 5% 1/4W	
R614	1-249-385-11	CARBON 2.2 5% 1/4W F	
R615	1-249-417-11	CARBON 1K 5% 1/4W	
R616	1-249-417-11	CARBON 1K 5% 1/4W	
R617	1-247-811-31	CARBON 150 5% 1/4W	
R618	1-249-419-11	CARBON 1.5K 5% 1/4W	
R619	1-249-421-11	CARBON 2.2K 5% 1/4W	
R627	1-249-377-11	CARBON 0.47 5% 1/4W F	
R628	1-249-377-11	CARBON 0.47 5% 1/4W F	
R629	1-249-377-11	CARBON 0.47 5% 1/4W F	
R630	1-249-437-11	CARBON 47K 5% 1/4W	
R631	1-215-472-00	METAL 130K 1% 1/4W	
R632	1-216-386-11	METAL OXIDE 0.56 5% 3W F	
R633	1-216-386-11	METAL OXIDE 0.56 5% 3W F	
R634	1-215-445-00	METAL 10K 1% 1/4W	
R636	1-216-482-11	METAL OXIDE 1.8K 5% 3W F	
R637	1-216-357-00	METAL OXIDE 4.7 5% 1W F	
R638	1-249-433-11	CARBON 22K 5% 1/4W	
R639	1-259-884-11	CARBON 4.7M 5% 1/4W	
R642	1-216-422-11	METAL OXIDE 18 5% 1W F	

REF. NO.	PART NO.	DESCRIPTION	REMARK
R643	1-249-424-11	CARBON 3.9K 5% 1/4W	
R644	1-249-429-11	CARBON 10K 5% 1/4W	
R645	1-249-433-11	CARBON 22K 5% 1/4W	
R646	1-249-424-11	CARBON 3.9K 5% 1/4W	
R647	1-249-429-11	CARBON 10K 5% 1/4W	
R648	1-249-417-11	CARBON 1K 5% 1/4W	
R649	1-247-895-00	CARBON 470K 5% 1/4W	
R650	1-259-881-11	CARBON 2.7M 5% 1/4W	
R660	Δ 1-247-903-00	CARBON 1M 5% 1/4W	
R661	1-216-492-11	METAL OXIDE 82K 5% 3W F	
<RELAY>			
RY601	Δ 1-515-738-11	RELAY	
RY602	Δ 1-515-738-11	RELAY	
<TRANSFORMER>			
T601	Δ 1-426-716-11	TRANSFORMER, LINE FILTER (LFT)	
T602	Δ 1-426-716-11	TRANSFORMER, LINE FILTER (LFT)	
T603	Δ 1-426-945-11	TRANSFORMER, POWER	
T604	Δ 1-426-947-11	TRANSFORMER, CONVERTER (SRT)	
<VARISTOR>			
VDR601	Δ 1-810-271-21	VARISTOR ZNR-14DK471U	

*A-1331-344-A C BOARD, COMPLETE			

4-382-854-11 SCREW (M3X10), P, SW (+)			
<CAPACITOR>			
C701	1-102-212-00	CERAMIC 820PF 10% 500V	
C702	1-102-116-00	CERAMIC 680PF 10% 50V	
C703	1-102-074-00	CERAMIC 0.001MF 10% 50V	
C704	1-126-964-11	ELECT 10MF 20% 50V	
C705	1-101-004-00	CERAMIC 0.01MF 50V	
C706	1-130-495-00	MYLAR 0.1MF 5% 50V	
C707	1-130-495-00	MYLAR 0.1MF 5% 50V	
C709	1-129-720-00	FILM 0.033MF 10% 400V	
C711	1-136-601-11	FILM 0.01MF 10% 630V	
C713	1-162-116-00	CERAMIC 680PF 10% 2KV	
C714	1-107-654-11	ELECT 33MF 20% 250V	
C715	1-102-074-00	CERAMIC 0.001MF 10% 50V	
C716	1-102-074-00	CERAMIC 0.001MF 10% 50V	
C717	1-102-074-00	CERAMIC 0.001MF 10% 50V	
C719	1-107-651-11	ELECT 4.7MF 20% 250V	
C771	1-102-121-00	CERAMIC 0.0022MF 10% 50V	
C781	1-126-964-11	ELECT 10MF 20% 50V	
C782	1-101-004-00	CERAMIC 0.01MF 50V	
C790	1-102-973-00	CERAMIC 100PF 5% 50V	
C791	1-101-004-00	CERAMIC 0.01MF 50V	
<CONNECTOR>			
CN702	*1-564-512-11	PLUG, CONNECTOR 9P	
CN703	*1-573-964-11	PIN, CONNECTOR (PC BOARD) 6P	
<DIODE>			
D704	8-719-911-19	DIODE 1SS119	



Les composants identifiés par une trame et une marque Δ sont critiques pour la sécurité. Ne les remplacer que par une pièce portant le numéro spécifique.

The components identified by shading and mark Δ are critical for safety. Replace only with part number specified.

REF. NO.	PART NO.	DESCRIPTION	REMARK	REF. NO.	PART NO.	DESCRIPTION	REMARK
D705	8-719-911-19	DIODE ISS119		R739	1-202-813-00	SOLID 22K 20% 1/2W	
D706	8-719-911-19	DIODE ISS119		R741	1-202-842-11	SOLID 220K 20% 1/2W	
D761	8-719-911-19	DIODE ISS119		R747	1-202-883-11	SOLID 680K 20% 1/2W	
D762	8-719-911-19	DIODE ISS119		R748	1-202-838-00	SOLID 100K 20% 1/2W	
D763	8-719-911-19	DIODE ISS119		R751	1-216-483-11	METAL OXIDE 2.7K 5% 3W	F
D771	8-719-109-84	DIODE RD5.1ESB1		R754	1-216-483-11	METAL OXIDE 2.7K 5% 3W	F
D772	8-719-911-19	DIODE ISS119		R757	1-216-483-11	METAL OXIDE 2.7K 5% 3W	F
D781	8-719-901-83	DIODE ISS83		R760	1-249-434-11	CARBON 27K 5% 1/4W	
D782	8-719-901-83	DIODE ISS83		R761	1-260-328-11	CARBON 1K 5% 1/2W	
D783	8-719-901-83	DIODE ISS83		R762	1-260-328-11	CARBON 1K 5% 1/2W	
D784	8-719-901-83	DIODE ISS83		R763	1-260-328-11	CARBON 1K 5% 1/2W	
<IC>				R771	1-249-425-11	CARBON 4.7K 5% 1/4W	
IC701	8-759-140-53	IC UPD4053BC		R772	1-249-429-11	CARBON 10K 5% 1/4W	
<JACK>				R773	1-215-904-11	METAL OXIDE 100K 5% 2W	F
J701	Δ 1-540-223-11	SOCKET, PICTURE TUBE		R774	1-247-895-00	CARBON 470K 5% 1/4W	
<COIL>				R775	1-249-425-11	CARBON 4.7K 5% 1/4W	
L707	1-410-671-31	INDUCTOR 47UH		R776	1-249-425-11	CARBON 4.7K 5% 1/4W	
<TRANSISTOR>				R777	1-247-887-00	CARBON 220K 5% 1/4W	
Q701	8-729-119-78	TRANSISTOR 2SC2785-HFE		R781	1-260-352-11	CARBON 100K 5% 1/2W	
Q702	8-729-119-78	TRANSISTOR 2SC2785-HFE		R782	1-260-352-11	CARBON 100K 5% 1/2W	
Q703	8-729-119-78	TRANSISTOR 2SC2785-HFE		R783	1-260-352-11	CARBON 100K 5% 1/2W	
Q704	8-729-326-11	TRANSISTOR 2SC2611		R784	1-215-904-11	METAL OXIDE 100K 5% 2W	F
Q705	8-729-326-11	TRANSISTOR 2SC2611		R790	1-249-427-11	CARBON 6.8K 5% 1/4W	
Q706	8-729-326-11	TRANSISTOR 2SC2611		R791	1-247-807-31	CARBON 100 5% 1/4W	
Q761	8-729-200-17	TRANSISTOR 2SA1091-0		R792	1-249-438-11	CARBON 56K 5% 1/4W	
Q762	8-729-200-17	TRANSISTOR 2SA1091-0		R793	1-249-432-11	CARBON 18K 5% 1/4W	
Q763	8-729-200-17	TRANSISTOR 2SA1091-0		R794	1-249-438-11	CARBON 56K 5% 1/4W	
Q771	8-729-255-12	TRANSISTOR 2SC2551-0		R795	1-249-419-11	CARBON 1.5K 5% 1/4W	
Q772	8-729-119-78	TRANSISTOR 2SC2785-HFE		R796	1-247-807-31	CARBON 100 5% 1/4W	
Q773	8-729-119-76	TRANSISTOR 2SA1175-HFE		<VARIABLE RESISTOR>			
Q781	8-729-200-17	TRANSISTOR 2SA1091-0		RV707	1-241-714-11	RES, ADJ, METAL FILM 110M	
Q782	8-729-200-17	TRANSISTOR 2SA1091-0		RV710	1-230-641-11	RES, ADJ, METAL GLAZE 2.2M	
Q783	8-729-200-17	TRANSISTOR 2SA1091-0		<TAB>			
Q784	8-729-255-12	TRANSISTOR 2SC2551-0		TB704	1-695-915-11	TAB (CONTACT)	
Q790	8-729-119-76	TRANSISTOR 2SA1175-HFE		*****			
<RESISTOR>				*A-1342-246-A V BOARD, COMPLETE			
R701	1-249-406-11	CARBON 120 5% 1/4W		*****			
R702	1-249-406-11	CARBON 120 5% 1/4W		4-382-854-11 SCREW (M3X10), P, SW (+)			
R703	1-249-406-11	CARBON 120 5% 1/4W		<CAPACITOR>			
R704	1-249-393-11	CARBON 10 5% 1/4W		C951	1-102-074-00	CERAMIC 0.001MF 10% 50V	
R705	1-249-393-11	CARBON 10 5% 1/4W		C952	1-102-125-00	CERAMIC 0.0047MF 10% 50V	
R706	1-249-393-11	CARBON 10 5% 1/4W		C961	1-161-830-00	CERAMIC 0.0047MF 500V	
R707	1-249-415-11	CARBON 680 5% 1/4W		C962	1-102-951-00	CERAMIC 15PF 5% 50V	
R713	1-249-415-11	CARBON 680 5% 1/4W		C963	1-107-638-11	ELECT 33MF 20% 160V	
R714	1-249-415-11	CARBON 680 5% 1/4W		C964	1-126-933-11	ELECT 100MF 20% 16V	
R719	1-216-483-11	METAL OXIDE 2.7K 5% 3W	F	C968	1-106-383-00	MYLAR 0.047MF 200V	
R722	1-216-483-11	METAL OXIDE 2.7K 5% 3W	F	C969	1-124-668-11	ELECT 2.2MF 20% 160V	
R725	1-216-483-11	METAL OXIDE 2.7K 5% 3W	F	C970	1-106-391-12	MYLAR 0.1MF 10% 200V	
R727	1-202-818-00	SOLID 1K 20% 1/2W		C971	1-126-157-11	ELECT 10MF 20% 16V	
R728	1-202-818-00	SOLID 1K 20% 1/2W		C972	1-107-883-11	ELECT 330MF 20% 16V	
R729	1-202-818-00	SOLID 1K 20% 1/2W		C973	1-106-383-00	MYLAR 0.047MF 200V	
R730	1-202-549-00	SOLID 100 10% 1/2W		C974	1-102-959-00	CERAMIC 22PF 5% 50V	
R735	1-216-367-11	METAL OXIDE 0.68 5% 2W	F	C975	1-126-933-11	ELECT 100MF 20% 16V	
				C976	1-126-157-11	ELECT 10MF 20% 16V	
				C977	1-102-963-00	CERAMIC 33PF 5% 50V	



REF. NO.	PART NO.	DESCRIPTION	REMARK
C978	1-130-471-00	MYLAR 0.001MF	5% 50V
C979	1-130-471-00	MYLAR 0.001MF	5% 50V
C980	1-126-964-11	ELECT 10MF	20% 50V
<CONNECTOR>			
CN901	*1-564-512-11	PLUG, CONNECTOR 9P	
<DIODE>			
D961	8-719-911-19	DIODE 1SS119	
D963	8-719-911-19	DIODE 1SS119	
D964	8-719-911-19	DIODE 1SS119	
D965	8-719-911-19	DIODE 1SS119	
D966	8-719-911-19	DIODE 1SS119	
D967	8-719-110-88	DIODE RD39ESB2	
D968	8-719-110-88	DIODE RD39ESB2	
<COIL>			
L962	1-408-416-00	INDUCTOR 39UH	
<TRANSISTOR>			
Q961	8-729-119-78	TRANSISTOR 2SC2785-HFE	
Q962	8-729-119-76	TRANSISTOR 2SA1175-HFE	
Q963	8-729-809-26	TRANSISTOR 2SA1606-E	
Q964	8-729-119-78	TRANSISTOR 2SC2785-HFE	
Q965	8-729-809-29	TRANSISTOR 2SC4159-E	
Q966	8-729-119-78	TRANSISTOR 2SC2785-HFE	
Q967	8-729-142-86	TRANSISTOR 2SC3733	
Q968	8-729-119-78	TRANSISTOR 2SC2785-HFE	
<RESISTOR>			
R951	1-249-434-11	CARBON 27K 5%	1/4W
R952	1-249-423-11	CARBON 3.3K 5%	1/4W
R953	1-249-423-11	CARBON 3.3K 5%	1/4W
R954	1-247-903-00	CARBON 1M 5%	1/4W
R955	1-249-421-11	CARBON 2.2K 5%	1/4W
R962	1-249-409-11	CARBON 220 5%	1/4W
R963	1-249-419-11	CARBON 1.5K 5%	1/4W
R964	1-260-311-11	CARBON 39 5%	1/2W
R965	1-249-414-11	CARBON 560 5%	1/4W F
R966	1-249-418-11	CARBON 1.2K 5%	1/4W
R968	1-249-418-11	CARBON 1.2K 5%	1/4W
R969	1-249-384-11	CARBON 1.8 5%	1/4W F
R970	1-249-435-11	CARBON 33K 5%	1/4W
R972	1-249-432-11	CARBON 18K 5%	1/4W
R974	1-216-476-11	METAL OXIDE 180 5%	3W F
R975	1-249-417-11	CARBON 1K 5%	1/4W F
R976	1-249-432-11	CARBON 18K 5%	1/4W
R977	1-249-438-11	CARBON 56K 5%	1/4W
R978	1-249-430-11	CARBON 12K 5%	1/4W
R979	1-249-414-11	CARBON 560 5%	1/4W
R980	1-249-420-11	CARBON 1.8K 5%	1/4W
R981	1-249-415-11	CARBON 680 5%	1/4W
R982	1-249-384-11	CARBON 1.8 5%	1/4W F
R983	1-249-441-11	CARBON 100K 5%	1/4W
R984	1-247-807-31	CARBON 100 5%	1/4W
R985	1-249-400-11	CARBON 39 5%	1/4W F
R986	1-249-435-11	CARBON 33K 5%	1/4W
R987	1-249-428-11	CARBON 8.2K 5%	1/4W
R988	1-249-415-11	CARBON 680 5%	1/4W

REF. NO.	PART NO.	DESCRIPTION	REMARK
R989	1-249-413-11	CARBON 470 5%	1/4W
R990	1-216-475-11	METAL OXIDE 120 5%	3W F
R991	1-249-409-11	CARBON 220 5%	1/4W

*A-1347-093-A		VC BOARD, COMPLETE	*****
<CAPACITOR>			
C1801	1-124-126-00	ELECT 47MF	20% 16V
C1803	1-124-126-00	ELECT 47MF	20% 16V
C1804	1-124-126-00	ELECT 47MF	20% 16V
C1805	1-136-157-00	FILM 0.022MF	5% 50V
C1808	1-130-471-00	MYLAR 0.001MF	5% 50V
C1809	1-130-471-00	MYLAR 0.001MF	5% 50V
C1810	1-136-171-00	FILM 0.33MF	5% 50V
C1811	1-136-171-00	FILM 0.33MF	5% 50V
C1812	1-126-320-11	ELECT 10MF	20% 16V
C1817	1-104-665-11	ELECT 100MF	20% 25V
C1820	1-107-710-11	ELECT 100MF	20% 35V
C1850	1-136-153-00	FILM 0.01MF	5% 50V
<CONNECTOR>			
CN801	1-573-300-11	CONNECTOR, BOARD TO BOARD 18P	
CN1850	1-564-517-11	PLUG, CONNECTOR 2P	
<DIODE>			
D1801	8-719-109-93	DIODE RD6.2ESB2	
D1802	8-719-109-93	DIODE RD6.2ESB2	
D1806	8-719-911-19	DIODE 1SS119	
D1817	8-719-987-87	DIODE ERA85-009	
D1818	8-719-987-87	DIODE ERA85-009	
D1822	8-719-109-93	DIODE RD6.2ESB2	
D1823	8-719-109-93	DIODE RD6.2ESB2	
D1824	8-719-987-87	DIODE ERA85-009	
D1850	8-719-911-19	DIODE 1SS119	
<IC>			
IC1801	8-759-231-53	IC TA7805S	
IC1802	8-759-135-80	IC UPC358C	
IC1803	8-759-902-21	IC SN74LS221N	
IC1850	8-759-603-37	IC M5216P	
<TRANSISTOR>			
Q1801	8-729-119-78	TRANSISTOR 2SC2785-HFE	
Q1802	8-729-119-76	TRANSISTOR 2SA1175-HFE	
Q1803	8-729-119-78	TRANSISTOR 2SC2785-HFE	
Q1804	8-729-119-76	TRANSISTOR 2SA1175-HFE	
Q1805	8-729-119-78	TRANSISTOR 2SC2785-HFE	
Q1806	8-729-385-82	TRANSISTOR 2SB858-C	
Q1807	8-729-809-26	TRANSISTOR 2SA1606-E	
Q1808	8-729-809-29	TRANSISTOR 2SC4159-E	
Q1809	8-729-119-76	TRANSISTOR 2SA1175-HFE	
Q1810	8-729-119-78	TRANSISTOR 2SC2785-HFE	
Q1811	8-729-208-71	TRANSISTOR 2SC3298B-0	
Q1850	8-729-119-78	TRANSISTOR 2SC2785-HFE	
Q1851	8-729-119-78	TRANSISTOR 2SC2785-HFE	

VC H3

REF. NO.	PART NO.	DESCRIPTION	REMARK	REF. NO.	PART NO.	DESCRIPTION	REMARK
<RESISTOR>							
R1801	1-215-866-11	METAL OXIDE 330 5%	1W F	D874	8-719-404-46	DIODE MA110	
R1802	1-247-887-00	CARBON 220K 5%	1/4W	D875	8-719-404-46	DIODE MA110	
R1803	1-215-467-00	METAL 82K 1%	1/4W	D876	8-719-404-46	DIODE MA110	
R1806	1-217-477-00	FUSIBLE 4.7 5%	1W F	<IC>			
R1808	1-247-887-00	CARBON 220K 5%	1/4W	IC871	8-759-165-26	IC SC402130B	
R1811	1-249-429-11	CARBON 10K 5%	1/4W	<COIL>			
R1812	1-249-417-11	CARBON 1K 5%	1/4W	L871	1-408-421-00	INDUCTOR 100UH	
R1813	1-215-473-00	METAL 150K 1%	1/4W	L872	1-408-429-00	INDUCTOR 470UH	
R1814	1-249-429-11	CARBON 10K 5%	1/4W	<TRANSISTOR>			
R1818	1-213-070-00	FUSIBLE 27 5%	1W F	Q871	8-729-901-01	TRANSISTOR DTC144EK	
R1819	1-215-913-11	METAL OXIDE 220 5%	3W F	Q872	8-729-901-98	TRANSISTOR 2SA1036K-R	
R1820	1-216-451-11	METAL OXIDE 120 5%	2W F	Q873	8-729-901-98	TRANSISTOR 2SA1036K-R	
R1822	1-249-409-11	CARBON 220 5%	1/4W F	Q874	8-729-901-01	TRANSISTOR DTC144EK	
R1823	1-249-401-11	CARBON 47 5%	1/4W F	Q875	8-729-901-01	TRANSISTOR DTC144EK	
R1825	1-215-455-00	METAL 27K 1%	1/4W	Q876	8-729-901-01	TRANSISTOR DTC144EK	
R1828	1-215-866-11	METAL OXIDE 330 5%	1W F	Q877	8-729-901-01	TRANSISTOR DTC144EK	
R1829	1-213-070-00	FUSIBLE 27 5%	1W F	Q878	8-729-901-04	TRANSISTOR DTA114EK	
R1830	1-217-477-00	FUSIBLE 4.7 5%	1W F	<RESISTOR>			
R1831	1-216-429-00	METAL OXIDE 270 5%	1W F	JR871	1-216-295-91	METAL GLAZE 0 5%	1/10W
R1846	1-249-429-11	CARBON 10K 5%	1/4W	JR872	1-216-295-91	METAL GLAZE 0 5%	1/10W
R1850	1-249-417-11	CARBON 1K 5%	1/4W	JR873	1-216-295-91	METAL GLAZE 0 5%	1/10W
R1851	1-215-451-00	METAL 18K 1%	1/4W	JR874	1-216-296-91	METAL GLAZE 0 5%	1/8W
R1852	1-215-455-00	METAL 27K 1%	1/4W	JR875	1-216-295-91	METAL GLAZE 0 5%	1/10W
R1853	1-215-452-00	METAL 20K 1%	1/4W	R871	1-216-294-00	METAL GLAZE 10M 5%	1/8W
R1854	1-215-447-00	METAL 12K 1%	1/4W	R872	1-216-089-91	METAL GLAZE 47K 5%	1/10W
R1855	1-215-445-00	METAL 10K 1%	1/4W	R873	1-216-065-00	METAL GLAZE 4.7K 5%	1/10W
R1856	1-215-427-00	METAL 1.8K 1%	1/4W	R874	1-216-073-00	METAL GLAZE 10K 5%	1/10W
R1857	1-249-422-11	CARBON 2.7K 5%	1/4W	R875	1-216-073-00	METAL GLAZE 10K 5%	1/10W
R1858	1-249-429-11	CARBON 10K 5%	1/4W	R876	1-216-065-00	METAL GLAZE 4.7K 5%	1/10W
R1859	1-249-422-11	CARBON 2.7K 5%	1/4W	R877	1-216-097-00	METAL GLAZE 100K 5%	1/10W
R1860	1-249-429-11	CARBON 10K 5%	1/4W	R878	1-216-009-00	METAL GLAZE 22 5%	1/10W
<VARIABLE RESISTOR>				R879	1-216-005-00	METAL GLAZE 15 5%	1/10W
RV1801	1-241-766-11	RES. ADJ. CERMET 47K		R880	1-216-009-00	METAL GLAZE 22 5%	1/10W
*****				R881	1-216-009-00	METAL GLAZE 22 5%	1/10W
*A-1372-005-A H3 BOARD, COMPLETE				R882	1-216-009-00	METAL GLAZE 22 5%	1/10W
*****				R883	1-216-009-00	METAL GLAZE 22 5%	1/10W
<CAPACITOR>				R884	1-216-089-91	METAL GLAZE 47K 5%	1/10W
C871	1-126-924-11	ELECT 330MF 20%	10V	R885	1-216-073-00	METAL GLAZE 10K 5%	1/10W
C872	1-163-035-00	CERAMIC CHIP 0.047MF	50V	R886	1-216-073-00	METAL GLAZE 10K 5%	1/10W
C873	1-126-952-11	ELECT 1000MF 20%	16V	R887	1-216-089-91	METAL GLAZE 47K 5%	1/10W
C874	1-163-009-11	CERAMIC CHIP 0.001MF	50V	R888	1-216-073-00	METAL GLAZE 10K 5%	1/10W
C875	1-163-037-11	CERAMIC CHIP 0.022MF	25V	<CRYSTAL>			
<CONNECTOR>				X871	1-577-082-11	VIBRATOR, CERAMIC	
CN871	*1-564-506-11	PLUG, CONNECTOR 3P		*****			
CN872	1-564-511-11	PLUG, CONNECTOR 8P					
CN873	*1-564-513-11	PLUG, CONNECTOR 10P					
CN874	*1-564-509-11	PLUG, CONNECTOR 6P					
CN875	1-564-505-11	PLUG, CONNECTOR 2P					
CN877	*1-573-299-11	CONNECTOR, BOARD TO BOARD 10P					
<DIODE>							
D871	8-719-404-46	DIODE MA110					
D872	8-719-404-46	DIODE MA110					
D873	8-719-404-46	DIODE MA110					

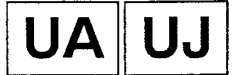

REF.NO.	PART NO.	DESCRIPTION	REMARK
*A-1373-467-A	UA BOARD, COMPLETE	*****	
<CAPACITOR>			
C171	1-126-933-11	ELECT 100MF	20% 10V
C172	1-126-964-11	ELECT 10MF	20% 50V
C173	1-163-031-11	CERAMIC CHIP 0.01MF	50V
C174	1-126-964-11	ELECT 10MF	20% 50V
C175	1-126-096-11	ELECT 10MF	20% 25V
C176	1-126-096-11	ELECT 10MF	20% 25V
C177	1-163-031-11	CERAMIC CHIP 0.01MF	50V
C178	1-163-009-11	CERAMIC CHIP 0.001MF	10% 50V
<CONNECTOR>			
CN171	1-691-803-11	SOCKET, DIN	
CN172	*1-564-520-11	PLUG, CONNECTOR 5P	
CN173	*1-564-518-11	PLUG, CONNECTOR 3P	
CN175	*1-564-520-11	PLUG, CONNECTOR 5P	
<DIODE>			
D171	8-719-110-17	DIODE RD10ESB2	
D172	8-719-110-17	DIODE RD10ESB2	
D173	8-719-911-19	DIODE 1SS119	
D174	8-719-404-46	DIODE MA110	
D175	8-719-404-46	DIODE MA110	
D176	8-719-404-46	DIODE MA110	
D177	8-719-404-46	DIODE MA110	
<IC>			
IC171	8-759-065-85	IC MAX232N	
<JACK>			
J171	1-563-760-11	JACK, MINIATUER (DIA. 3.5)	
J172	1-563-760-11	JACK, MINIATUER (DIA. 3.5)	
<COIL>			
L171	1-422-613-11	COIL, AIR CORE	
L172	1-422-613-11	COIL, AIR CORE	
L173	1-422-613-11	COIL, AIR CORE	
L174	1-422-613-11	COIL, AIR CORE	
L175	1-422-613-11	COIL, AIR CORE	
L176	1-422-613-11	COIL, AIR CORE	
L177	1-422-613-11	COIL, AIR CORE	
L178	1-422-613-11	COIL, AIR CORE	
<TRANSISTOR>			
Q171	8-729-901-01	TRANSISTOR DTC144EK	
Q172	8-729-901-06	TRANSISTOR DTA144EK	
<RESISTOR>			
R171	1-216-025-00	METAL GLAZE 100 5%	1/10W
R172	1-216-025-00	METAL GLAZE 100 5%	1/10W
R173	1-216-057-00	METAL GLAZE 2.2K 5%	1/10W
R174	1-216-049-00	METAL GLAZE 1K 5%	1/10W
R175	1-216-049-00	METAL GLAZE 1K 5%	1/10W

REF.NO.	PART NO.	DESCRIPTION	REMARK
R176	1-216-025-00	METAL GLAZE 100 5%	1/10W
R177	1-216-049-00	METAL GLAZE 1K 5%	1/10W
<TAB>			
TB171	1-537-187-11	TERMINAL, PUSH (4P)	

*A-1373-468-A	UJ BOARD, COMPLETE	*****	
<CAPACITOR>			
C101	1-124-589-11	ELECT 47MF	20% 16V
C102	1-124-589-11	ELECT 47MF	20% 16V
C103	1-164-232-11	CERAMIC CHIP 0.01MF	10% 50V
C104	1-126-157-11	ELECT 10MF	20% 16V
C105	1-126-157-11	ELECT 10MF	20% 16V
C106	1-124-589-11	ELECT 47MF	20% 16V
C107	1-124-589-11	ELECT 47MF	20% 16V
C108	1-126-157-11	ELECT 10MF	20% 16V
C109	1-126-157-11	ELECT 10MF	20% 16V
C110	1-124-589-11	ELECT 47MF	20% 16V
C111	1-124-589-11	ELECT 47MF	20% 16V
C112	1-124-589-11	ELECT 47MF	20% 16V
C113	1-126-157-11	ELECT 10MF	20% 16V
C114	1-126-157-11	ELECT 10MF	20% 16V
C115	1-124-767-00	ELECT 2.2MF	20% 50V
C116	1-124-767-00	ELECT 2.2MF	20% 50V
C117	1-124-589-11	ELECT 47MF	20% 16V
C118	1-164-232-11	CERAMIC CHIP 0.01MF	10% 50V
C119	1-163-035-00	CERAMIC CHIP 0.047MF	50V
C120	1-163-123-00	CERAMIC CHIP 180PF	5% 50V
<CONNECTOR>			
CN101	*1-566-641-11	CONNECTOR, HINGE (TAB) 18P	
CN102	*1-566-641-11	CONNECTOR, HINGE (TAB) 18P	
CN103	1-564-517-11	PLUG, CONNECTOR 2P	
<DIODE>			
D101	8-719-110-17	DIODE RD10ESB2	
D102	8-719-110-17	DIODE RD10ESB2	
D103	8-719-110-17	DIODE RD10ESB2	
D104	8-719-110-17	DIODE RD10ESB2	
D105	8-719-110-17	DIODE RD10ESB2	
D106	8-719-110-17	DIODE RD10ESB2	
D107	8-719-110-17	DIODE RD10ESB2	
D108	8-719-110-17	DIODE RD10ESB2	
D109	8-719-110-17	DIODE RD10ESB2	
D110	8-719-110-17	DIODE RD10ESB2	
D111	8-719-110-17	DIODE RD10ESB2	
D112	8-719-110-17	DIODE RD10ESB2	
D113	8-719-110-17	DIODE RD10ESB2	
D114	8-719-110-17	DIODE RD10ESB2	
D115	8-719-109-89	DIODE RD5.6ESB2	
D116	8-719-109-89	DIODE RD5.6ESB2	
D117	8-719-110-17	DIODE RD10ESB2	
<JACK>			
J101	1-573-969-11	JACK BLOCK, PIN	
J102	1-573-969-11	JACK BLOCK, PIN	



REF. NO.	PART NO.	DESCRIPTION	REMARK	REF. NO.	PART NO.	DESCRIPTION	REMARK
J103	1-573-969-11	JACK BLOCK, PIN					
J104	1-573-969-11	JACK BLOCK, PIN					
J105	1-573-969-11	JACK BLOCK, PIN					
J106	1-537-764-11	TERMINAL BOARD ASSY, I/O					
J108	1-537-764-11	TERMINAL BOARD ASSY, I/O					
J110	1-537-765-11	TERMINAL BOARD ASSY, I/O					
<TRANSISTOR>							
Q101	8-729-120-28	TRANSISTOR 2SC1623-L5L6					
Q102	8-729-120-28	TRANSISTOR 2SC1623-L5L6					
Q103	8-729-120-28	TRANSISTOR 2SC1623-L5L6					
Q104	8-729-120-28	TRANSISTOR 2SC1623-L5L6					
Q105	8-729-120-28	TRANSISTOR 2SC1623-L5L6					
<RESISTOR>							
R101	1-215-394-00	METAL 75 1% 1/4W					
R102	1-215-394-00	METAL 75 1% 1/4W					
R103	1-215-394-00	METAL 75 1% 1/4W					
R104	1-216-099-00	METAL GLAZE 120K 5% 1/10W					
R105	1-216-065-00	METAL GLAZE 4.7K 5% 1/10W					
R106	1-216-099-00	METAL GLAZE 120K 5% 1/10W					
R107	1-216-065-00	METAL GLAZE 4.7K 5% 1/10W					
R108	1-215-394-00	METAL 75 1% 1/4W					
R109	1-215-394-00	METAL 75 1% 1/4W					
R110	1-215-394-00	METAL 75 1% 1/4W					
R111	1-216-099-00	METAL GLAZE 120K 5% 1/10W					
R112	1-216-065-00	METAL GLAZE 4.7K 5% 1/10W					
R113	1-216-099-00	METAL GLAZE 120K 5% 1/10W					
R114	1-216-065-00	METAL GLAZE 4.7K 5% 1/10W					
R115	1-216-073-00	METAL GLAZE 10K 5% 1/10W					
R116	1-216-079-00	METAL GLAZE 18K 5% 1/10W					
R117	1-216-055-00	METAL GLAZE 1.8K 5% 1/10W					
R118	1-215-394-00	METAL 75 1% 1/4W					
R119	1-215-394-00	METAL 75 1% 1/4W					
R120	1-216-073-00	METAL GLAZE 10K 5% 1/10W					
R121	1-216-079-00	METAL GLAZE 18K 5% 1/10W					
R122	1-216-055-00	METAL GLAZE 1.8K 5% 1/10W					
R123	1-215-394-00	METAL 75 1% 1/4W					
R124	1-216-073-00	METAL GLAZE 10K 5% 1/10W					
R125	1-216-079-00	METAL GLAZE 18K 5% 1/10W					
R126	1-216-055-00	METAL GLAZE 1.8K 5% 1/10W					
R127	1-216-099-00	METAL GLAZE 120K 5% 1/10W					
R128	1-216-065-00	METAL GLAZE 4.7K 5% 1/10W					
R129	1-216-099-00	METAL GLAZE 120K 5% 1/10W					
R130	1-216-065-00	METAL GLAZE 4.7K 5% 1/10W					
R131	1-216-099-00	METAL GLAZE 120K 5% 1/10W					
R132	1-216-689-11	METAL GLAZE 39K 5% 1/10W					
R133	1-215-394-00	METAL 75 1% 1/4W					
R134	1-216-099-00	METAL GLAZE 120K 5% 1/10W					
R135	1-216-689-11	METAL GLAZE 39K 5% 1/10W					
R136	1-215-394-00	METAL 75 1% 1/4W					
R137	1-216-013-00	METAL GLAZE 33 5% 1/10W					
R138	1-216-013-00	METAL GLAZE 33 5% 1/10W					
R139	1-216-013-00	METAL GLAZE 33 5% 1/10W					
R140	1-216-055-00	METAL GLAZE 1.8K 5% 1/10W					
R141	1-216-039-00	METAL GLAZE 390 5% 1/10W					
R142	1-216-055-00	METAL GLAZE 1.8K 5% 1/10W					
R143	1-216-039-00	METAL GLAZE 390 5% 1/10W					

				*A-1394-545-A	UT BOARD, COMPLETE	*****	
				<CAPACITOR>			
				C201	1-163-031-11	CERAMIC CHIP 0.01MF	50V
				C202	1-163-031-11	CERAMIC CHIP 0.01MF	50V
				C203	1-163-031-11	CERAMIC CHIP 0.01MF	50V
				C204	1-163-031-11	CERAMIC CHIP 0.01MF	50V
				C205	1-163-031-11	CERAMIC CHIP 0.01MF	50V
				C206	1-163-031-11	CERAMIC CHIP 0.01MF	50V
				C207	1-163-035-00	CERAMIC CHIP 0.047MF	50V
				C208	1-163-031-11	CERAMIC CHIP 0.01MF	50V
				C209	1-163-031-11	CERAMIC CHIP 0.01MF	50V
				C210	1-163-031-11	CERAMIC CHIP 0.01MF	50V
				C211	1-163-031-11	CERAMIC CHIP 0.01MF	50V
				C212	1-163-031-11	CERAMIC CHIP 0.01MF	50V
				C213	1-163-035-00	CERAMIC CHIP 0.047MF	50V
				C214	1-137-368-11	FILM 0.0047MF	5% 50V
				C215	1-136-165-00	FILM 0.1MF	5% 50V
				C216	1-137-368-11	FILM 0.0047MF	5% 50V
				C217	1-136-165-00	FILM 0.1MF	5% 50V
				C218	1-137-374-11	FILM 0.047MF	5% 50V
				C219	1-163-035-00	CERAMIC CHIP 0.047MF	50V
				C220	1-163-035-00	CERAMIC CHIP 0.047MF	50V
				C221	1-164-232-11	CERAMIC CHIP 0.01MF	10% 50V
				C223	1-163-035-00	CERAMIC CHIP 0.047MF	50V
				C224	1-163-035-00	CERAMIC CHIP 0.047MF	50V
				C225	1-163-035-00	CERAMIC CHIP 0.047MF	50V
				C226	1-163-241-11	CERAMIC CHIP 39PF	5% 50V
				C227	1-126-940-11	ELECT 330MF	20% 16V
				C228	1-124-126-00	ELECT 47MF	20% 16V
				C229	1-126-964-11	ELECT 10MF	20% 50V
				C230	1-126-964-11	ELECT 10MF	20% 50V
				C231	1-126-964-11	ELECT 10MF	20% 50V
				C232	1-126-934-11	ELECT 220MF	20% 16V
				C233	1-126-964-11	ELECT 10MF	20% 50V
				C234	1-126-964-11	ELECT 10MF	20% 50V
				C235	1-124-126-00	ELECT 47MF	20% 16V
				C236	1-124-903-11	ELECT 1MF	20% 50V
				C237	1-124-903-11	ELECT 1MF	20% 50V
				C238	1-126-933-11	ELECT 100MF	20% 16V
				C239	1-124-126-00	ELECT 47MF	20% 16V
				C240	1-124-126-00	ELECT 47MF	20% 16V
				C242	1-126-964-11	ELECT 10MF	20% 50V
				C243	1-126-935-11	ELECT 470MF	20% 6.3V
				C244	1-126-964-11	ELECT 10MF	20% 50V
				C245	1-126-923-11	ELECT 220MF	20% 10V
				C246	1-124-126-00	ELECT 47MF	20% 16V
				C247	1-126-964-11	ELECT 10MF	20% 50V
				C248	1-124-903-11	ELECT 1MF	20% 50V
				C249	1-126-964-11	ELECT 10MF	20% 50V
				C250	1-126-964-11	ELECT 10MF	20% 50V
				C251	1-126-964-11	ELECT 10MF	20% 50V
				C252	1-163-035-00	CERAMIC CHIP 0.047MF	50V
				C253	1-124-126-00	ELECT 47MF	20% 16V
				C254	1-163-031-11	CERAMIC CHIP 0.01MF	50V
				C255	1-163-031-11	CERAMIC CHIP 0.01MF	50V
				C256	1-136-171-00	FILM 0.33MF	5% 50V
				C257	1-124-925-11	ELECT 2.2MF	20% 50V
				C258	1-163-249-11	CERAMIC CHIP 82PF	5% 50V
				C259	1-137-364-11	FILM 0.001MF	5% 50V
				C260	1-163-121-00	CERAMIC CHIP 150PF	5% 50V

UT

REF. NO.	PART NO.	DESCRIPTION	REMARK	REF. NO.	PART NO.	DESCRIPTION	REMARK	
C261	1-163-035-00	CERAMIC CHIP	0.047MF	50V	Q204	8-729-120-28	TRANSISTOR 2SC1623-L5L6	
C262	1-124-126-00	ELECT	47MF	20%	16V	Q205	8-729-120-28	TRANSISTOR 2SC1623-L5L6
C263	1-163-243-11	CERAMIC CHIP	47PF	5%	50V	Q206	8-729-120-28	TRANSISTOR 2SC1623-L5L6
C270	1-124-903-11	ELECT	1MF	20%	50V	Q207	8-729-216-22	TRANSISTOR 2SA1162-G
C271	1-124-927-11	ELECT	4.7MF	20%	50V	Q208	8-729-216-22	TRANSISTOR 2SA1162-G
C272	1-124-903-11	ELECT	1MF	20%	50V	Q211	8-729-120-28	TRANSISTOR 2SC1623-L5L6
C273	1-124-126-00	ELECT	47MF	20%	16V	Q212	8-729-120-28	TRANSISTOR 2SC1623-L5L6
C274	1-163-035-00	CERAMIC CHIP	0.047MF	50V	Q213	8-729-120-28	TRANSISTOR 2SC1623-L5L6	
C275	1-124-126-00	ELECT	47MF	20%	16V	Q214	8-729-120-28	TRANSISTOR 2SC1623-L5L6
C276	1-136-167-00	FILM	0.15MF	5%	50V	Q215	8-729-216-22	TRANSISTOR 2SA1162-G
C277	1-136-157-00	FILM	0.022MF	5%	50V	Q216	8-729-901-01	TRANSISTOR DTC144EK
C278	1-124-925-11	ELECT	2.2MF	20%	50V	Q217	8-729-120-28	TRANSISTOR 2SC1623-L5L6
C279	1-163-249-11	CERAMIC CHIP	82PF	5%	50V	Q218	8-729-120-28	TRANSISTOR 2SC1623-L5L6
C280	1-137-364-11	FILM	0.001MF	5%	50V	Q219	8-729-216-22	TRANSISTOR 2SA1162-G
C281	1-163-251-11	CERAMIC CHIP	100PF	5%	50V	Q220	8-729-120-28	TRANSISTOR 2SC1623-L5L6
C282	1-124-126-00	ELECT	47MF	20%	16V	Q221	8-729-120-28	TRANSISTOR 2SC1623-L5L6
C283	1-163-035-00	CERAMIC CHIP	0.047MF	50V	Q222	8-729-901-01	TRANSISTOR DTC144EK	
C290	1-124-927-11	ELECT	4.7MF	20%	50V	Q223	8-729-120-28	TRANSISTOR 2SC1623-L5L6
<CONNECTOR>								
CN201	*1-566-367-11	CONNECTOR, HINGE (RECEPTACLE)			Q224	8-729-216-22	TRANSISTOR 2SA1162-G	
CN202	*1-566-367-11	CONNECTOR, HINGE (RECEPTACLE)			Q225	8-729-216-22	TRANSISTOR 2SA1162-G	
CN203	*1-564-506-11	PLUG, CONNECTOR 3P			Q226	8-729-120-28	TRANSISTOR 2SC1623-L5L6	
CN204	1-573-300-11	CONNECTOR, BOARD TO BOARD 18P			Q227	8-729-120-28	TRANSISTOR 2SC1623-L5L6	
CN205	1-573-300-11	CONNECTOR, BOARD TO BOARD 18P			Q228	8-729-120-28	TRANSISTOR 2SC1623-L5L6	
CN206	1-564-505-11	PLUG, CONNECTOR 2P			Q229	8-729-120-28	TRANSISTOR 2SC1623-L5L6	
<DIODE>				<RESISTOR>				
D202	8-719-911-19	DIODE 1SS119		JR1	1-216-295-91	METAL GLAZE	0 5% 1/10W	
D203	8-719-911-19	DIODE 1SS119		JR2	1-216-295-91	METAL GLAZE	0 5% 1/10W	
D205	8-719-911-19	DIODE 1SS119		JR4	1-216-295-91	METAL GLAZE	0 5% 1/10W	
D206	8-719-109-68	DIODE RD3.6ESB1		R201	1-216-057-00	METAL GLAZE	2.2K 5% 1/10W	
<FILTER>								
FL201	1-239-550-11	FILTER, LOW PASS		R202	1-216-025-00	METAL GLAZE	100 5% 1/10W	
FL202	1-239-550-11	FILTER, LOW PASS		R203	1-216-057-00	METAL GLAZE	2.2K 5% 1/10W	
FL203	1-239-550-11	FILTER, LOW PASS		R204	1-216-025-00	METAL GLAZE	100 5% 1/10W	
<IC>								
IC201	8-752-067-28	IC CXA1545AS		R205	1-216-033-00	METAL GLAZE	220 5% 1/10W	
IC202	8-741-765-01	IC SBX1765-01		R206	1-216-033-00	METAL GLAZE	220 5% 1/10W	
IC203	8-759-800-81	IC LA7016		R207	1-216-049-00	METAL GLAZE	1K 5% 1/10W	
IC204	8-759-245-75	IC TA8184P		R208	1-216-033-00	METAL GLAZE	220 5% 1/10W	
IC205	8-752-058-68	IC CXA1315M		R209	1-216-033-00	METAL GLAZE	220 5% 1/10W	
IC206	8-759-009-82	IC NC14011BF-T2		R210	1-216-033-00	METAL GLAZE	220 5% 1/10W	
IC207	8-759-800-81	IC LA7016		R211	1-216-081-00	METAL GLAZE	22K 5% 1/10W	
IC208	8-759-009-82	IC NC14011BF-T2		R212	1-216-081-00	METAL GLAZE	22K 5% 1/10W	
<COIL>								
L201	1-408-421-00	INDUCTOR	100UH	R213	1-216-081-00	METAL GLAZE	22K 5% 1/10W	
L202	1-408-421-00	INDUCTOR	100UH	R214	1-216-081-00	METAL GLAZE	22K 5% 1/10W	
L203	1-408-421-00	INDUCTOR	100UH	R215	1-216-089-91	METAL GLAZE	47K 5% 1/10W	
L204	1-408-414-00	INDUCTOR	27UH	R217	1-216-081-00	METAL GLAZE	22K 5% 1/10W	
L205	1-408-414-00	INDUCTOR	27UH	R218	1-216-089-91	METAL GLAZE	47K 5% 1/10W	
<TRANSISTOR>								
Q201	8-729-120-28	TRANSISTOR 2SC1623-L5L6		R219	1-216-049-00	METAL GLAZE	1K 5% 1/10W	
Q202	8-729-120-28	TRANSISTOR 2SC1623-L5L6		R220	1-216-049-00	METAL GLAZE	1K 5% 1/10W	
Q203	8-729-120-28	TRANSISTOR 2SC1623-L5L6		R221	1-216-081-00	METAL GLAZE	22K 5% 1/10W	
				R222	1-216-049-00	METAL GLAZE	1K 5% 1/10W	
				R223	1-216-071-00	METAL GLAZE	8.2K 5% 1/10W	
				R224	1-216-033-00	METAL GLAZE	220 5% 1/10W	
				R225	1-216-033-00	METAL GLAZE	220 5% 1/10W	
				R226	1-216-049-00	METAL GLAZE	1K 5% 1/10W	
				R227	1-216-035-00	METAL GLAZE	270 5% 1/10W	
				R228	1-216-049-00	METAL GLAZE	1K 5% 1/10W	
				R229	1-216-071-00	METAL GLAZE	8.2K 5% 1/10W	
				R230	1-216-057-00	METAL GLAZE	2.2K 5% 1/10W	
				R232	1-216-295-91	METAL GLAZE	0 5% 1/10W	
				R233	1-216-061-00	METAL GLAZE	3.3K 5% 1/10W	

UT H

REF. NO.	PART NO.	DESCRIPTION	REMARK	REF. NO.	PART NO.	DESCRIPTION	REMARK	
R234	1-216-025-00	METAL GLAZE 100 5%	1/10W	R1209	1-216-073-00	METAL GLAZE 10K 5%	1/10W	
R235	1-216-057-00	METAL GLAZE 2.2K 5%	1/10W	R1210	1-216-069-00	METAL GLAZE 6.8K 5%	1/10W	
R236	1-216-081-00	METAL GLAZE 22K 5%	1/10W	R1211	1-216-057-00	METAL GLAZE 2.2K 5%	1/10W	
R237	1-216-077-00	METAL GLAZE 15K 5%	1/10W	R1212	1-216-073-00	METAL GLAZE 10K 5%	1/10W	
R238	1-216-077-00	METAL GLAZE 15K 5%	1/10W	R1213	1-216-063-00	METAL GLAZE 3.9K 5%	1/10W	
R239	1-216-043-00	METAL GLAZE 560 5%	1/10W	R1214	1-216-073-00	METAL GLAZE 10K 5%	1/10W	
R240	1-216-065-00	METAL GLAZE 4.7K 5%	1/10W	R1215	1-216-069-00	METAL GLAZE 6.8K 5%	1/10W	
R241	1-216-025-00	METAL GLAZE 100 5%	1/10W	R1216	1-216-055-00	METAL GLAZE 1.8K 5%	1/10W	
R242	1-216-025-00	METAL GLAZE 100 5%	1/10W	R1217	1-216-033-00	METAL GLAZE 220 5%	1/10W	
R243	1-216-067-00	METAL GLAZE 5.6K 5%	1/10W	R1218	1-216-089-91	METAL GLAZE 47K 5%	1/10W	
R248	1-216-065-00	METAL GLAZE 4.7K 5%	1/10W	R1219	1-216-115-00	METAL GLAZE 560K 5%	1/10W	
R249	1-216-043-00	METAL GLAZE 560 5%	1/10W	R1220	1-216-049-00	METAL GLAZE 1K 5%	1/10W	
R250	1-216-077-00	METAL GLAZE 15K 5%	1/10W	R1221	1-216-053-00	METAL GLAZE 1.5K 5%	1/10W	
R251	1-216-081-00	METAL GLAZE 22K 5%	1/10W	R1222	1-216-085-00	METAL GLAZE 33K 5%	1/10W	
R252	1-216-077-00	METAL GLAZE 15K 5%	1/10W	R1223	1-216-075-00	METAL GLAZE 12K 5%	1/10W	
R253	1-216-053-00	METAL GLAZE 1.5K 5%	1/10W			<VARIABLE RESISTOR>		
R254	1-216-045-00	METAL GLAZE 680 5%	1/10W	RV201	1-241-761-11	RES, ADJ, CARBON 1K		
R255	1-216-053-00	METAL GLAZE 1.5K 5%	1/10W	RV202	1-241-763-11	RES, ADJ, CARBON 4.7K		
R256	1-216-053-00	METAL GLAZE 1.5K 5%	1/10W	*****				
R257	1-216-081-00	METAL GLAZE 22K 5%	1/10W			H BOARD, COMPLETE		
R258	1-216-077-00	METAL GLAZE 15K 5%	1/10W			*****		
R259	1-216-025-00	METAL GLAZE 100 5%	1/10W			9-908-867-01 HOLDER, LED		
R260	1-216-065-00	METAL GLAZE 4.7K 5%	1/10W			9-908-869-01 KEY TOP		
R261	1-216-025-00	METAL GLAZE 100 5%	1/10W			9-990-891-01 BOARD, REFLECTION A		
R262	1-216-035-00	METAL GLAZE 270 5%	1/10W			9-990-892-01 BOARD, DISPENSION A		
R263	1-216-067-00	METAL GLAZE 5.6K 5%	1/10W			<CAPACITOR>		
R264	1-216-043-00	METAL GLAZE 560 5%	1/10W					
R265	1-216-025-00	METAL GLAZE 100 5%	1/10W					
R266	1-216-033-00	METAL GLAZE 220 5%	1/10W					
R267	1-216-091-00	METAL GLAZE 56K 5%	1/10W	C1111	1-126-157-11	ELECT 10MF 20% 16V		
R268	1-216-061-00	METAL GLAZE 3.3K 5%	1/10W			<DIODE>		
R271	1-216-075-00	METAL GLAZE 12K 5%	1/10W	D1111	9-908-868-01	DIODE TLY263P		
R272	1-216-073-00	METAL GLAZE 10K 5%	1/10W	D1112	8-719-802-17	DIODE TLY263P		
R273	1-216-073-00	METAL GLAZE 10K 5%	1/10W	D1113	8-719-802-17	DIODE TLY263P		
R274	1-216-069-00	METAL GLAZE 6.8K 5%	1/10W	D1114	8-719-802-17	DIODE TLY263P		
R275	1-216-033-00	METAL GLAZE 220 5%	1/10W	D1115	8-719-802-17	DIODE TLY263P		
R276	1-216-053-00	METAL GLAZE 1.5K 5%	1/10W	D1116	8-719-802-17	DIODE TLY263P		
R277	1-216-117-00	METAL GLAZE 680K 5%	1/10W	D1117	8-719-802-17	DIODE TLY263P		
R278	1-216-089-91	METAL GLAZE 47K 5%	1/10W	D1118	8-719-802-17	DIODE TLY263P		
R279	1-216-061-00	METAL GLAZE 3.3K 5%	1/10W	D1119	8-719-802-17	DIODE TLY263P		
R280	1-216-039-00	METAL GLAZE 390 5%	1/10W	D1120	8-719-802-17	DIODE TLY263P		
R282	1-216-065-00	METAL GLAZE 4.7K 5%	1/10W	D1121	8-719-802-17	DIODE TLY263P		
R283	1-216-045-00	METAL GLAZE 680 5%	1/10W	D1122	8-719-802-17	DIODE TLY263P		
R284	1-216-065-00	METAL GLAZE 4.7K 5%	1/10W	D1123	8-719-802-17	DIODE TLY263P		
R285	1-216-089-91	METAL GLAZE 47K 5%	1/10W	D1124	8-719-802-17	DIODE TLY263P		
R286	1-216-097-00	METAL GLAZE 100K 5%	1/10W	D1125	8-719-802-17	DIODE TLY263P		
R288	1-216-067-00	METAL GLAZE 5.6K 5%	1/10W	D1126	8-719-802-17	DIODE TLY263P		
R289	1-216-073-00	METAL GLAZE 10K 5%	1/10W	D1127	8-719-802-17	DIODE TLY263P		
R290	1-216-073-00	METAL GLAZE 10K 5%	1/10W	D1128	8-719-802-17	DIODE TLY263P		
R291	1-216-077-00	METAL GLAZE 15K 5%	1/10W	D1129	8-719-802-17	DIODE TLY263P		
R292	1-216-073-00	METAL GLAZE 10K 5%	1/10W	D1130	8-719-802-17	DIODE TLY263P		
R294	1-216-089-91	METAL GLAZE 47K 5%	1/10W	D1131	8-719-802-17	DIODE TLY263P		
R295	1-216-071-00	METAL GLAZE 8.2K 5%	1/10W	D1132	8-719-802-17	DIODE TLY263P		
R296	1-216-085-00	METAL GLAZE 33K 5%	1/10W	D1133	8-719-802-17	DIODE TLY263P		
R298	1-216-055-00	METAL GLAZE 1.8K 5%	1/10W	D1134	8-719-911-19	DIODE 1SS119		
R299	1-216-071-00	METAL GLAZE 8.2K 5%	1/10W	D1135	8-719-911-19	DIODE 1SS119		
R1201	1-216-079-00	METAL GLAZE 18K 5%	1/10W	D1136	8-719-911-19	DIODE 1SS119		
R1202	1-216-069-00	METAL GLAZE 6.8K 5%	1/10W	D1137	8-719-911-19	DIODE 1SS119		
R1203	1-216-059-00	METAL GLAZE 2.7K 5%	1/10W			<IC>		
R1204	1-216-051-00	METAL GLAZE 1.2K 5%	1/10W					
R1205	1-216-055-00	METAL GLAZE 1.8K 5%	1/10W					
R1206	1-216-055-00	METAL GLAZE 1.8K 5%	1/10W					
R1207	1-216-057-00	METAL GLAZE 2.2K 5%	1/10W					
R1208	1-216-065-00	METAL GLAZE 4.7K 5%	1/10W					

The components identified by shading and mark Δ are critical for safety. Replace only with part number specified.

Les composants identifiés par une trame et une marque Δ sont critiques pour la sécurité. Ne les remplacer que par une pièce portant le numéro spécifié.



REF. NO.	PART NO.	DESCRIPTION	REMARK
IC1111	9-902-229-01	IC GP1U52R	
<RESISTOR>			
R1111	1-247-807-11	CARBON 100 5% 1/4W	
R1112	1-247-807-11	CARBON 100 5% 1/4W	
R1113	1-247-879-11	CARBON 100K 5% 1/4W	
R1114	1-247-879-11	CARBON 100K 5% 1/4W	
R1115	1-247-879-11	CARBON 100K 5% 1/4W	
R1116	1-247-879-11	CARBON 100K 5% 1/4W	
R1117	1-249-408-11	CARBON 180 5% 1/4W	
R1118	1-249-403-11	CARBON 68 5% 1/4W	
R1119	1-249-408-11	CARBON 180 5% 1/4W	
R1120	1-249-408-11	CARBON 180 5% 1/4W	
R1121	1-249-408-11	CARBON 180 5% 1/4W	
R1122	1-249-408-11	CARBON 180 5% 1/4W	
<SWITCH>			
S1111	1-554-303-21	SWITCH, KEY BOARD	
S1112	1-554-303-21	SWITCH, KEY BOARD	
S1113	1-554-303-21	SWITCH, KEY BOARD	
S1114	1-554-303-21	SWITCH, KEY BOARD	
S1115	1-554-303-21	SWITCH, KEY BOARD	
S1116	1-554-303-21	SWITCH, KEY BOARD	
S1117	1-554-303-21	SWITCH, KEY BOARD	
S1119	1-554-303-21	SWITCH, KEY BOARD	
S1120	1-554-303-21	SWITCH, KEY BOARD	
S1121	1-554-303-21	SWITCH, KEY BOARD	
S1122	1-554-303-21	SWITCH, KEY BOARD	
S1123	1-554-303-21	SWITCH, KEY BOARD	
S1124	1-554-118-00	SWITCH, PUSH (1 KEY)	

MISCELLANEOUS			

Δ 1-402-715-21		COIL, DEMAGNETIZATION (PVM-2950QM)	
Δ 1-402-716-21		COIL, DEMAGNETIZATION (PVM-2950QM)	
Δ 1-426-573-22		COIL, DEGAUSSING (PVM-2950Q)	
Δ 1-426-574-22		COIL, DEGAUSSING (PVM-2950Q)	
Δ 1-452-616-13		NECK ASSY, PICTURE TUBE (NA323)	
1-467-794-11		KEY BOARD UNIT	
Δ 1-580-375-11		INLET 3P	
1-900-140-13		LEAD ASSY, FOCUS	
Δ 8-451-394-31		DEFLECTION YOKE (Y29EXA)	
V901 Δ 8-733-845-05		PICTURE TUBE (M68KUZ10X)	

ACCESSORIES AND PACKING MATERIALS			

Δ 1-557-377-11		CORD, POWER (3 CORE) (10.0A/125V) (PVM-2950Q)	
Δ 1-590-151-11		CORD SET, POWER (10.0A/250V) (PVM-2950QM)	
2-990-242-01		HOLDER (B), PLUG (PVM-2950Q/2950QM(AEP))	
3-170-078-01		HOLDER (B), PLUG (PVM-2950QM(AUS))	
3-759-190-21		MANUAL, INSTRUCTION	
*4-039-562-02		CUSHION (RIGHT UPPER FRONT)	
*4-039-566-02		CUSHION (LEFT UPPER LOWER)	
*4-039-570-01		CUSHION (UPPER) (ASSY)	
*4-039-571-01		CUSHION (LOWER) (ASSY)	
*4-044-688-01		INDIVIDUAL CARTON (PVM-2950QM)	

REF. NO.	PART NO.	DESCRIPTION	REMARK
*4-044-689-01		INDIVIDUAL CARTON (PVM-2950Q)	
*4-388-954-01		BAG, PROTECTION	
REMOTE COMMANDER			
1-467-798-11		REMOTE COMMANDER (RM-854)	
9-901-890-11		COVER, BATTERY (FOR RM-854)	

PVM-2950Q/2950QM
RM-854